



Pertanika Journal of
**SOCIAL SCIENCES
& HUMANITIES**

JSSH

VOL. 22 (3) SEPT. 2014



PERTANIKA
JOURNALS

A scientific journal published by Universiti Putra Malaysia Press

Journal of Social Sciences & Humanities

About the Journal

Pertanika is an international peer-reviewed journal devoted to the publication of original papers, and it serves as a forum for practical approaches to improving quality in issues pertaining to tropical agriculture and its related fields. Pertanika began publication in 1978 as the Journal of Tropical Agricultural Science. In 1992, a decision was made to streamline Pertanika into three journals to meet the need for specialised journals in areas of study aligned with the interdisciplinary strengths of the university.

The revamped Journal of Social Sciences & Humanities (JSSH) aims to develop as a pioneer journal for the Social Sciences with a focus on emerging issues pertaining to the social and behavioural sciences as well as the humanities, particularly in the Asia Pacific region. Other Pertanika series include Pertanika Journal of Tropical Agricultural Science (JTAS); and Pertanika Journal of Science and Technology (JST).

JSSH is published in **English** and it is open to authors around the world regardless of the nationality. It is currently published four times a year i.e. in **March, June, September** and **December**.

Goal of *Pertanika*

Our goal is to bring the highest quality research to the widest possible audience.

Quality

We aim for excellence, sustained by a responsible and professional approach to journal publishing. Submissions are guaranteed to receive a decision within 12 weeks. The elapsed time from submission to publication for the articles averages 5-6 months.

Indexing of *Pertanika*

Pertanika is now over 33 years old; this accumulated knowledge has resulted Pertanika JSSH being indexed in SCOPUS (Elsevier), EBSCO, Thomson (ISI) Web of Knowledge [CAB Abstracts], DOAJ, Google Scholar, ISC, Citefactor, Rubriq and MyAIS.

Future vision

We are continuously improving access to our journal archives, content, and research services. We have the drive to realise exciting new horizons that will benefit not only the academic community, but society itself.

We also have views on the future of our journals. The emergence of the online medium as the predominant vehicle for the 'consumption' and distribution of much academic research will be the ultimate instrument in the dissemination of research news to our scientists and readers.

Aims and Scope

Pertanika Journal of Social Sciences & Humanities aims to provide a forum for high quality research related to social sciences and humanities research. Areas relevant to the scope of the journal include: *Accounting, Agricultural & resource economics, Anthropology, Communication, Community and peace studies, Design and architecture, Disaster and crisis management, Economics, Education, Extension education, Finance, Gerontology, Hospitality and tourism, Human ecology, Human resource development, Language studies (education, applied linguistics, acquisition, pedagogy), Language literature (literary & cultural studies), Management, Marketing, Psychology, Safety and environment, Social and behavioural sciences, Sociology, Sustainable development, and Ethnic relations.*

Editorial Statement

Pertanika is the official journal of Universiti Putra Malaysia. The abbreviation for Pertanika Journal of Social Sciences & Humanities is *Pertanika J. Soc. Sci. Hum.*

EDITOR-IN-CHIEF

Mohd. Shahwahid Hj. Othman

Economics, Natural Resource & Environmental Economics, Economics Valuation

CHIEF EXECUTIVE EDITOR

Nayan Deep S. Kanwal

Environmental Issues – Landscape Plant Modelling Applications

UNIVERSITY PUBLICATIONS COMMITTEE

Mohd Azmi Mohd Lila, Chair

EDITORIAL STAFF

Journal Officers:

Nik Lee Yin, ScholarOne

Kanagamalar Silvarajoo, ScholarOne

Editorial Assistants:

Siti Juridah Mat Arip

Zulinaardawati Kamarudin

COPY EDITORS

Doreen Dillah

Crescentia Morais

Ena Bhattacharyya

PRODUCTION STAFF

Pre-press Officer:

Nik Khairul Azizi Nik Ibrahim

Layout & Typeset:

Sarwani Padzil

Noor Sholihah Mohd Daud

Norhafizah Abd Rani

WEBMASTER

Almaz Hong (Freelance)

PUBLICITY & PRESS RELEASE

Magdalene Pokar (ResearchSEA)

EDITORIAL OFFICE

JOURNAL DIVISION

Office of the Deputy Vice Chancellor (R&I)

1st Floor, IDEA Tower II

UPM-MTDC Technology Centre

Universiti Putra Malaysia

43400 Serdang, Selangor Malaysia.

Gen Enq.: +603 8947 1622 | 1619 | 1616

E-mail: executive_editor.pertanika@upm.my

URL: www.journals-ijd.upm.edu.my

PUBLISHER

Kamariah Mohd Saidin

UPM Press

Universiti Putra Malaysia

43400 UPM, Serdang, Selangor, Malaysia.

Tel: +603 8946 8855, 8946 8854

Fax: +603 8941 6172

E-mail: penerbit@putra.upm.edu.my

URL: <http://penerbit.upm.edu.my>

EDITORIAL BOARD

2013-2015

Abdul Mansur M. Masih

Economics, Econometrics, Finance, King Fahd University of Petroleum and Minerals, Saudi Arabia.

Alan Maley

English Language Studies, Teaching of English Language and Literature, Leeds Metropolitan University, UK.

Ali Reza Kaldi

Medical Sociology, Sociology of Development Ageing, Gerontology, University of Social Welfare and Rehabilitation, Tehran, Iran.

Aminah Ahmad

Sociology, Gender and Development, Universiti Putra Malaysia, Malaysia.

Bee-Hoon Tan

English Language Studies and Applied Linguistics, with Special Research Interest in e-learning and Learning Support, Universiti Putra Malaysia, Malaysia.

Brian Tomlinson

English Language Studies, The Evaluation, Adaptation and Development, Leeds Metropolitan University, UK.

Deanna L. Sharpe

Economics, Consumer and Family Economics, Personal Finance, The University of Missouri, Columbia, USA.

Dessy Irawati

International Business Management, Strategic Management, Economic Geography, Globalization and Development Studies, Industrial Dynamics and Knowledge Transfer, Radboud University, the Netherlands and EduPRIME the consulting, the Netherlands.

Elias @ Ilias Salleh

Architectural Science, Sustainable Tropical Design, Thermal Comfort, Universiti Kebangsaan Malaysia, Malaysia.

Gong-Soog Hong

Economics, Consumer and Family Sciences, The Ohio State University, USA.

Jacqueline Pugh-Kitingan

Music, Ethnomusicology, Borneo and Papua New Guinea Studies, Universiti Malaysia Sabah, Malaysia.

James R. Stock

Management Studies, Marketing, Logistics and Supply Chain Management, Quantitative Method, University of South Florida, USA.

Jayakaran Mukundan

English Language Studies, Teaching English as a Second Language (TESL), English Language Studies, Universiti Putra Malaysia, Malaysia.

Jayum A. Jawan

Sociology, Politics and Government, Civilization Studies, Universiti Putra Malaysia, Malaysia.

Jonathan Newton

Classroom-based Second Language Acquisition, Language Teaching Methodology, the Interface of Culture and Language in Language Teaching and Learning, and Language/Communication Training and Material Design for the Multicultural Workplace, Victoria University of Wellington, New Zealand.

Marcus Bion GRIFFIN

Human Ecology, Anthropology, Tropical Agriculture, Fisheries, Cultural Learning Solutions, USA.

Mary Susan Philip

English Language Theatre in Malaysia and Singapore; Postcolonial Theatre, University of Malaya, Malaysia.

Muzafar Shah Habibullah

Economics, Monetary Economics, Banking, Macroeconomics, Universiti Putra Malaysia, Malaysia.

Patricia Matusky

Music, Ethnomusicology, Malay and Indonesian language, Literature and Culture, Grand Valley State University, USA.

Samsinar Md.Sidin

Management Studies, Marketing, Consumer Behaviour, Universiti Putra Malaysia, Malaysia.

Shameem Rafik-Galea

English Language Studies, Linguistics, Applied Linguistics, Language and Communication, Universiti Putra Malaysia, Malaysia.

Shamsher Mohamad

Ramadili Mohd

Finance, Corporate Governance, The Global University of Islamic Finance (INCEIF) Malaysia.

Stephen J. Hall

English Language Studies, Linguist, Teacher Educator, TESOL, Sunway University College, Malaysia.

Stephen J. Thoma

Psychology, Educational Psychology, The University of Alabama, USA.

Swee-Heng Chan

English Language Studies, Universiti Putra Malaysia, Malaysia.

Turirman Suandi

Psychology, Youth Development and Volunteerism, Universiti Putra Malaysia, Malaysia.

Victor T. King

Anthropology / Southeast Asian Studies White Rose East Asia Centre, University of Leeds, UK.

INTERNATIONAL ADVISORY BOARD

2013-2016

Carolyn Graham

Music, Jazz Chants, Harvard University, USA.

David Nunan

Vice-President: Academic, Anaheim University, California, English Language Studies, Linguist, TESOL, University of Hong Kong, Hong Kong.

Faith Trent AM FACE

Education: Curriculum development, Flinders University, Adelaide, Australia.

Gary N. Mclean

Executive Director, International Human Resource Development Programs, EAHR, Human Resource Development for National, Community and Social Development, International Human Resource Development, Organizational Development, Texas A&M University, USA.

Graham Thurgood

English Language Studies, General Linguistics, Discourse and Syntax, California State University, Chico., USA.

Handoyo Puji Widodo

English Language Studies, ESP, Language Curriculum-Materials Design and Development, and Language Methodology, Politeknik Negeri Jember, East Java-Indonesia.

John R. Schermerhorn Jr.

Management Studies, Management and Organizational Behaviour, International Business, Ohio University, USA.

Kent Matthews

Economics, Banking and Finance, Modelling and Forecasting the Macro Economy, Cardiff Business School, UK.

Lehman B. Fletcher

Economics, Agricultural Development, Policy Analysis and Planning, Iowa State University, USA.

Mark P. Orbe

Communication, Interpersonal Communication, Communication and Diversity, Intercultural Communication, Western Michigan University, USA.

Mohamed ARIFF

Economics, Finance, Capital Market, Islamic Finance, Fiscal Policy, Bond University, Australia.

Pal Ahluwalia

Pro Vice-Chancellor (Research and Innovation), African Studies, Social and Cultural Theory, Post-colonial Theory, Division of Education, Arts & Social Sciences, University of Portsmouth, United Kingdom.

Phillip Jones

Architectural Science, Sustainability in the Built Environment, Welsh School of Architecture, Cardiff University, UK.

Rance P. L. Lee

Sociology, The Chinese University of Hong Kong.

Royal D. Colle

Communication, Cornell University, USA.

Vijay K. Bhatia

Education: Genre Analysis and Professional Communication, City University of Hong Kong

ABSTRACTING/INDEXING

Pertanika is now over 35 years old; this accumulated knowledge has resulted the journals being indexed in SCOPUS (Elsevier), Thomson (ISI) Web of Knowledge [BIOSIS & CAB Abstracts], EBSCO, DOAJ, Google Scholar, AGRICOLA, ISC, Citefactor, Rubriq and MyAIS.



The publisher of *Pertanika* will not be responsible for the statements made by the authors in any articles published in the journal. Under no circumstances will the publisher of this publication be liable for any loss or damage caused by your reliance on the advice, opinion or information obtained either explicitly or implied through the contents of this publication.

All rights of reproduction are reserved in respect of all papers, articles, illustrations, etc., published in *Pertanika*. *Pertanika* provides free access to the full text of research articles for anyone, web-wide. It does not charge either its authors or author-institution for refereeing/publishing outgoing articles or user-institution for accessing incoming articles.

No material published in *Pertanika* may be reproduced or stored on microfilm or in electronic, optical or magnetic form without the written authorization of the Publisher.

Copyright © 2014-15 Universiti Putra Malaysia Press. All Rights Reserved.



Pertanika Journal of Social Sciences & Humanities
Vol. 22 (3) Sept. 2014

Contents

Foreword	i
<i>Nayan Deep S. Kanwal</i>	
Review Article	
Cross-disciplinary and Cross-linguistic Manifestation of Theme in Academic Writing	695
<i>Ebrahimi, S. F., Chan, S. H. and Tan, B. H.</i>	
Short Communication	
The Relationship between Religiosity and Happiness among Students in an Iranian University	709
<i>Ali Asghar Bayani</i>	
Regular Articles	
Learning Station Method in Special Education Programs for Students with Learning Disabilities	717
<i>Mohd Hanafi Mohd Yasin, Hasnah Toran, Mohd Mokhtar Tahar, Lokman Tahir and Suriawati Nawawi</i>	
Influence of Parents' Jobs on Apprentices' Work Values	729
<i>Nur Surayyah Madhubala Abdullah, Chee Chen Soon and Abdul Rahman Md. Aroff</i>	
Promoting Receptive Vocabulary Growth among Undergraduates: Focused In-Class Reading with Writing Activity	747
<i>Nor Ashikin, A. M., Johana, Y. and Pandian, A.</i>	
Developing Students' Creative Response to Literary Texts in the ESL Classroom	763
<i>Adzura Elier Ahmad and Li Sheau Juin</i>	
Teachers' Self-Efficacy in Teaching Family Life Education	775
<i>Rahimah, J., Abu, R., Ismail, H. and Mat Rashid, A.</i>	
Investigating Thomas Hardy's Reaction to Victorian Religious Forces through Reading <i>Tess of the D'Urbervilles</i> and <i>Jude the Obscure</i>	785
<i>Faezeh Sivandipour and Rosli Talif</i>	

A Stylistic Analysis of News English-Arabic Translation <i>Kais Amir Kadhim</i>	797
Entrepreneurial Leadership Behaviour among School Principals: Perspectives from Malaysian Secondary School Teachers <i>Zaidatul Akmaliah Lope Pihie, Afsaneh Bagheri and Soaib Asimiran</i>	825
Assessing Graduates' Generic Skills: An Indicator of Employability <i>Parmjit Singh, Roslind Xaviour Thambusamy and Adlan Ramly</i>	845
Computer-Mediated Communication Use Among Adolescents and Its Implication for Psychological Need Satisfaction <i>Chin-Siang Ang, Mansor Abu Talib, Jo-Pei Tan and Siti Nor Yaacob</i>	861
Human Governance and Firm's Leverage Decision: Evidence from Malaysian Listed Companies <i>Irene Wei Kiong Ting, Noor Azlinna Azizan and Qian Long Kweh</i>	879
Terras (<i>Eusideroxylon zwageri</i> Teijsm. & Binn.), a Cultural Keystone Species of the Berawan People of Sarawak, Malaysia <i>Franco, F. M., Ghani, B. A. A. and Hidayati, S.</i>	891
Diasporic Dwellings: The Family House and its Role in the Creative Imaginary of Selected Malaysian Indian Writers <i>Shangeetha, R. K. and Pillai, S.</i>	903
Classroom Talk – A Significant Consideration in Developing an Analytical Framework <i>Dass, L. C., Normah, A., Arumugam, N. and Dillah, D.</i>	917

Foreword

Welcome to the **Third Issue 2014** of the Journal of Social Sciences and Humanities (JSSH)!

JSSH is an open-access journal for the Social Sciences and Humanities that is published by Universiti Putra Malaysia Press. It is independently owned and managed by the university and run on a non-profit basis for the benefit of the world-wide social science community.

This issue contains **16 articles**. The authors of these articles come from **Malaysia** and **Iran**.

The articles cover a wide range of topics, from an analysis of the stylistic changes in English-Arabic translation texts of the British Broadcasting Corporation's political news (*Kais Amir Kadhim*), a study on the relationships among online self-disclosure, online communication and psychological need satisfaction of Malaysian adolescents (*Ang Chin Siang, Mansor Abu Talib, Tan Jo Pei and Siti Nor Yaacob*), a study investigating the influences of human governance, namely CEO's attributes on a firm's leverage decision (*Irene Wei Kiong Ting, Noor Azlinna Binti Azizan and Qian Long Kweh*), to a study that revealed the unique position accorded to the terras tree in the Berawan culture in Sarawak, Malaysia (*Franco, F.M., Ghani, B.A.A. and Hidayati, S.*).

The research studies, on topics related to education, language, literature and psychology, include a study to determine the effectiveness of the Learning Station Method (LSM) in the Special Education Programme for students with learning disabilities (*Mohd Hanafi Mohd Yasin, Hasnah Toran, Lokman Tahir and Suraiwati Nawawi*), a research investigating the effect of focused in-class reading with writing activity on Malay undergraduate students' receptive vocabulary knowledge (*Nor Ashikin, A.M., Johana, Y. and Pandian, A.*), a study that examined the relationship between parents' jobs and the work values of apprentices (*Nur Surayyah Madhubala Abdullah, Chee Chen Soon and Abdul Rahman Md. Aroff*), a study that explored the acquisition of skills and language as part of holistic learning through the precepts of Project-Based Learning (*Adzura Elier Ahmad and Li Sheau Juin*), a study investigating teachers' self-efficacy in teaching family life (*Rahimah, J., Abu, R., Ismail, H. and Mat Rashid, A.*), research work to determine Malaysian secondary school principals' entrepreneurial leadership behaviour through teachers' perspectives (*Zaidatul Akmaliah Lope Pihie, Afsaneh Bagheri and Soaib Asimiran*), a concept paper that proposed the use of Graduate Employability Model (GEM) to generate a more stringent quantitative and summative quotient of the Malaysian university graduates' employability as indicated by their generic skills (*Parmjit Singh, Roslind Xaviour Thambusamy and Adlan Ramly*), a study that involved the development of frameworks to analyse data sets gathered in a Malaysian undergraduate setting, focusing particularly on literature by prominent researchers in classroom discourse (*Laura Christ Dass,*

Normah Abdullah, Nalini Arumugam and Doreen Dillah), an article that analysed the effect of religious and social problems of the Victorian era on Thomas Hardy through his novels *Tess of the D'Urbervilles* and *Jude the Obscure* (*Faezeh Sivandipour and Rosli Talif*), a discussion that revealed a small section of the variations in the articulation and perception of the concept of the house, and its varying features as it dwells in the pages of three Malaysian Indian novelists (*Shangeetha, R.K. and Pillai, S.*), a review of the issue of theme in cross-disciplinary and cross-linguistic studies (*Ebrahimi S. F., Chan S. H. and Tan B.H.*), and a study on the relationship between religion and happiness as espoused by undergraduate Iranian Muslim students (*Ali Asghar Bayni*).

I anticipate that you will find the evidence presented in this issue to be intriguing, thought provoking, and useful in reaching new milestones. Please recommend the journal to your colleagues and students to make this endeavour meaningful.

I would also like to express my gratitude to all the contributors who have made this issue possible, as well as the authors, reviewers and editors for their professional contribution. Last but not least, the editorial assistance of the journal division staff is also fully appreciated.

JSSH is currently accepting manuscripts for upcoming issues based on original qualitative or quantitative research that opens new areas of inquiry and investigation.

Chief Executive Editor

Nayan Deep S. KANWAL, [FRSA](#), [ABIM](#), [AMIS](#), [Ph.D.](#)
nayan@upm.my

Review Article

Cross-disciplinary and Cross-linguistic Manifestation of Theme in Academic Writing

Ebrahimi, S. F.*, Chan, S. H. and Tan, B. H.

Department of English, Faculty of Modern Languages and Communication, Universiti Putra Malaysia, 43400 Serdang, Selangor, Malaysia

ABSTRACT

There is considerable agreement among linguists that theme acts as a cohesive device in texts. It plays a major role in message organization and in enabling it to be communicated and understood clearly. Although one issue in writing is how writers apply this cohesive device in their writing, the question of how theme manifestation is affected by the writers' disciplinary or linguistic background has received little attention. Therefore, this paper aims to review the issue of theme in cross-disciplinary and cross-linguistic studies. The reviewed studies supported the earlier claim that theme application is packed differently across different disciplines and linguistics.

Keywords: Theme, academic writing, thematic structure, cross-disciplinary studies, cross-linguistic studies

INTRODUCTION

Scholars investigated the importance of theme as a cohesive device to see how information is packed cohesively in similar genre by writers from different disciplines (Whittaker, 1995; Ghaddesy, 1999; North,

2005; Idding, 2008; Ebrahimi & Khedri, 2011) or linguistics (Ghabanchi, 1990; Williams, 2005; Zhou, 2006; Jalilifar & Khedri, 2011). These scholars suggested that theme application is affected by the writers' disciplinary or linguistic background which implies that information in similar genre is packed differently in different disciplines and languages.

The paper aims to review empirical studies done in the area of thematic manifestation in similar genre across different disciplines and linguistics. This

ARTICLE INFO

Article history:

Received: 14 March 2013

Accepted: 20 April 2013

E-mail addresses:

seyedfoade@yahoo.com (Ebrahimi, S. F.),

shchan@upm.edu.my (Chan, S. H.),

tanbh@upm.edu.my (Tan, B. H.)

* Corresponding author

paper will briefly describe the background and definition of theme in the second section. Consequently, discussions on in turn, data gathering procedures, method, findings and discussion, conclusion, and further suggested studies will be presented.

DEFINING THEME

Halliday's notion of theme is descended from Systemic Functional Grammar which is articulated by Halliday in the 1960s. Systemic Functional Grammar is a grammar model which focuses mainly on the choices that are provided by the grammatical system for language speaker. These choices are pretend to be meaningful and link speakers' intention to concrete forms of language expression (Matthiessen & Halliday, 1997).

Matthiessen and Halliday (1997, pp. 12-13) argue that Systemic Functional Grammar considers the choices to be manifested in the clause through three metafunctions. Therefore, clause is made by a combination of three metafunctions; interpersonal, ideational and textual.

1. Interpersonal metafunction: It deals with speaker and listener interaction and how grammatical choices help enact the social role generally, and speech role particularly through dialogic interactions, such as, establishing, changing, and maintaining interpersonal relations. Mood as one of its major grammatical systems expressed in a clause is the grammaticalization of speech function.
2. Ideational metafunction: It deals with ideation which is the grammatical choice

for structuring our experience of the world around and inside us. Transitivity as one of its major grammatical systems is the resource for constructing our experience. It includes a process, the participants in the process, and circumstances attendant on it.

3. Textual metafunction: It deals with text development. This is done through presenting the ideational and interpersonal meanings as shared information between speaker and listener in text unfolding in context. Theme as one of the major textual systems is the resource for providing a local context for clause operation through selecting a local point of departure in the flow of information.

In Matthiessen and Halliday's (1997, p. 19) mind, the textual metafunction which, as stated by Gosden (1992), is manifested as theme in the clause engenders resources for presenting interpersonal and ideational meanings as information organized into text that can be ongoingly exchanged between producer and receiver. This involves transitions in the development of text (conjunctive relations) and the assignment of different textual statuses. These transitions and statuses enable the exchange of information where the producer guides the receiver in interpreting the unfolding text.

Theme definitions are classified into two parts of pure and applied definitions. In the former, the scholars just provide us with the definition of theme, but in the latter, scholars provide us with definitions of theme as well

as the practical side of the definitions, and its application in language teaching contexts.

Different functional definitions of theme and rheme are found in the work of different scholars. Halliday (1985, p. 30) defines theme as:

“An element which serves as the point of departure of the message and what the speaker has in mind to start with. It is the element in a particular structural configuration taken as whole, organizes the clause as a message. The remainder of the message is called the rheme. Therefore, a clause consists of a theme combined with a rheme and the sentence is expressed by order. The order is theme followed by rheme”.

Halliday (1994, p. 39) elaborated further by stating that “theme is what clause is about, and it comes in the first position, but this position is not what defines the theme; it is a means which realizes the function of the theme”.

McCarthy (1991, p. 52) mentioned that theme is applied by the addresser to highlight a piece of information in the sentence. For example, it is quite common that “in spoken narratives and anecdotes, the speaker will often front-place key orientational features for their listener”. These features are mainly place and time markers such as *one day, then, suddenly, once upon a time*. Therefore, theme is felt to be important for the message receiver.

Belmonte and McCabe (2000, p. 2) considered the theme from a cognitive-communicative perspective. They claimed that theme functionally combines expressions of speaker’s perception of reality and their concerns to communicate these perceptions, so it has two perspectives: a cognitive perspective which refers to the world of experience and a communicative perspective which refers to its discursal role.

Fries (1992, p. 1) declared that students (native and non-native English speakers) suffer from the difficulty in ordering the words in their sentences. Teachers as well sometimes struggle with the difficulty of giving explanations about information ordering in the sentences to students. To overcome these hardships, two concepts of theme and information focus are of great help. Theme is the point of departure of the clause as message. Since theme is realized in the first part of the clause in English, it can be easily recognized. Fries also illustrated that theme is an important cohesive element which must receive great attention while writing.

Brown and Yule (1983, p. 125) stated that one of the constraints on the speaker and writer is that they can produce only one word at a time when they are producing their message. They have to choose a beginning point for their utterance in order to organize their message. The initial point is important in the clause and also in the discourse. It influences the hearer’s and reader’s interpretation of everything that follows in the discourse since it constitutes

the initial textual context for everything that follows. What is placed in the initial position is called theme.

Leonard and Huraki (2005, p. 2) argued that information which is situated at the end of one clause is mostly used as a starting point of the next clause. Since theme is the starting point of the clause, it serves the function of relating the clauses in the text logically. The articles reviewed in this study are mostly based on Halliday's (1985, 1994, 2004) definition of theme.

METHODOLOGY OF REVIEW

The articles which were reviewed in this paper were gathered through a search of electronic data bases for the key terms of theme, theme in research article, theme in writing, cross-disciplinary studies on theme, theme and translation, and theme across different languages. Time limitation was not applied in searching the electronic data bases to include all the studies which have been done in this area. The search by the above mentioned key terms yielded 8 articles directly related to the focus subject. The search through the references of these 8 articles yielded 1 more article. The articles which were reviewed for this study are presented in Appendix A.

This review is based on the review guidelines proposed by Creswell (1994), who set the goal of a review paper as summarizing the current state of knowledge concerning the topic under review and highlighting the important issues the earlier studies have left unresolved.

The review of this paper was done by gathering articles and categorizing them as cross-disciplinary and cross-linguistic studies as it is a concern of the researchers to possibly extend the scope of theme investigation. Each article was reviewed for its topic, corpus, model, method and findings. The strengths, weaknesses and limitations of each article were highlighted. The last stage was the discussion of the strengths, weaknesses and limitations, and putting forward some directions for future research.

FINDINGS FROM THE REVIEW

The findings and the discussion of earlier studies will be classified into two parts, i) cross-disciplinary, and ii) cross-linguistic studies on the theme.

Cross-disciplinary studies on theme

The cross-disciplinary studies on theme presented in this section concern theme in different genres of essay writing, research article, and research article abstract in the broad genre of academic writing.

Thematic organization in the academic article abstracts was investigated by Ghadessy (1999). He ran his study on a corpus of 150 abstracts, written by both native and non-native speakers, from 30 different academic disciplines at Hong Kong Baptist University. He analyzed the data based on Halliday's (1994) model of thematic organization including simple, multiple, marked, unmarked, textual and interpersonal theme. The result indicated

that theme is manifested differently across different disciplines. In the case of the simple theme, the result reported Geography as having the highest frequency of 84.6% while the lowest was in Finance with 47.4%. Multiple theme was another theme type which was treated differently. In Finance abstracts, this theme manifestation had the highest application with 52.6 and while the lowest application was reported in Plant Pathology with 10%. The other theme which was treated differently by different disciplines was the unmarked theme. Sociology abstracts used this theme type in 100% of their clauses while this theme type was used only up to 70.6% in Film and Cinema abstracts. Regarding the marked theme, Film and Cinema used it in 29.4% of all the theme variations while the marked theme was totally neglected in Sociology abstracts.

While, this study supported the hypothesis that application of theme in different disciplines is different, the findings cannot be overgeneralized as a) the result of this study did not compare or contrast with other studies in the same area as even the writer himself claimed a lack of studies in the area, b) the data were not large enough to generalize the result as there were only 5 abstracts from each discipline even if they were taken from high reputed journals, they can not be deemed as representative of the disciplines, c) thematic structure is inter and intra sentence structured which means that not only thematic organization but also thematic progression need a light to be shed on and d) the unit of analysis was

the clause but if it is a dependent, then the thematic structure must be focused on the independent clause in order to be correct.

Types of information that authors of academic articles in two disciplines, Economics and Linguistics, place in thematic positions was investigated by Whittaker (1995). The unit of analysis for the study was the orthographic sentences or clause complex. She analyzed eight academic articles, four on each discipline and her corpus consisted of 40000 words taken from the reading texts which students of English at the Language Center of Madrid Autonomous University were given as part of their course. The thematic analysis was based on over 1500 examples. The data on ideational themes confirmed Halliday's claim that this type of writing depends heavily on relational processes. She concluded that academic articles can be expected to have few interpersonal themes (under 10%), and this can be attributed to the impersonal tone of academic articles. The result showed somewhat similarity between two disciplines in case of the textual and interpersonal themes. The mean of the textual theme was 8.8 and 8.5, while the interpersonal theme was 17.7 and 17.4 in Applied Linguistics and Economics research articles, respectively. The findings of her study showed disciplinary differences between the two focused disciplines in the case of the ideational theme and its process types.

The strong points of this study were: a) it analyzed all the thematic types and processes involved in thematic organization

proposed by Halliday (1985), b) it selected orthographic sentences or clause complex as unit of analysis, and c) it gave a thorough description and exemplification of the gained results, however, shortcomings of this study were: a) this study was run on a small corpus; therefore, the result is not generalizable, b) this study, following other studies presented in this paper, focused merely on thematic organization and neglected thematic progression which is important in tracing of thematic development across sentences or clause complexes of the text, c) the result were not statistically meaningful since no comparisons were made with earlier studies, and d) the researcher did not focus on the thematic types of the interpersonal and textual themes.

The research conducted by Ebrahimi and Khedri (2011) attempted to see how thematic structures are handled by research article writers from different disciplines while contributing their new knowledge in the abstract section of research article. Following Halliday's (1994) model of thematic organization and the revised model on the patterns of thematic progression pattern proposed by McCabe's (1999), they analyzed a corpus of 10 academic research article abstracts from two disciplines (5 in Chemical Engineering and 5 in Applied Linguistics) to clarify the possible similarities and variations between these two disciplines in light of thematic selection. They used the t-unit as unit of analysis.

The results indicated disciplinary differences regarding use of the textual and interpersonal themes. In Chemistry,

writers used 14% interpersonal and 27% textual themes, while in Applied Linguistics these themes manifested in 5% and 23% of the total themes respectively. The result also showed that the number of the simple topical themes was proportionally greater in Applied Linguistics abstracts than that of Chemistry ones. A significant point was that while the marked theme was found in 8% of the t-units in Applied Linguistics abstracts, this theme was not used at all in the Chemistry abstracts.

In case of thematic progression, linear chain, the chain in which the item in the rheme of the first clause becomes the theme of the subsequent clause, was used more in Chemistry abstracts compared to Applied Linguistics research article abstracts. The findings also reported more use of the constant pattern in the Chemistry abstracts. While the split theme chain, the chain in which the item in the theme of the first clause is also selected as the theme of the following clause, was manifested only for once in the Applied Linguistics abstracts, this pattern was not occurred in the Chemistry abstracts. Finally, the miscellaneous pattern, which is outside McCabe's (1999) model, was analyzed. The result showed more application of this thematic pattern in Applied Linguistics abstracts when compared to the Chemistry abstracts. The gained result showed overall disciplinary differences between the two analyzed disciplines in terms of thematic organization and progression patterns.

The strong points of this study were a) the gained results were compared and

contrasted with other studies in the similar and different genres which make the result to be statistically meaningful, b) the analyzed corpus were taken from highly reputed journals (ISI), c) the corpus were analyzed for both thematic organization types and thematic progression patterns which shows the structure of the information inter and intra clause, and d) the unit of analysis was the t-unit which could give more clearer results as it includes both the independent and its dependent clause(s) as one unit.

The drawbacks of this study were a) the corpus was not large enough for generalizing the result, b) the result of this study was not supported by examples from the analyzed data, and c) the corpus was not analyzed for subcategories of thematic organization types.

In a research conducted by Idding (2008), he studied the use of theme in two disciplines of English Humanities and Biochemistry. He analyzed six texts which were selected from peer-reviewed academic journals, three from each discipline. He used Halliday's (1994) model of thematic organization and the result illustrated disciplinary differences in terms of the interpersonal (7% in English Humanities and 1% in Biochemistry) and the unmarked themes (94% in English Humanities and 79% in Biochemistry), and disciplinary similarity in terms of the textual theme (26% in both disciplines).

The strong point of this study was it analyzed disciplines from soft and hard sciences. Shortcomings of this study were: a) the corpus was too small for

overgeneralizing the result, b) the study focused only on thematic organization types, c) the result was statistically not meaningful since it was not compared or contrasted with other studies and d) the result was not supported by examples.

To investigate the theme in students' essays North (2005) analyzed 61 essays written by 20 students about the history of science. Ten students had science background while the other ten had art background knowledge. Out of the 61 essays, 28 were written by art students and 33 were written by science students. The essays were written as a part of course assessment. The data contained 65234 words.

The data analysis declared that art students obtained higher marks for their essays compared to science students. This suggests greater tendency towards including the orienting themes (textual, interpersonal, interpersonal and experiential elements). These themes provide the reader with explicit guidance on the way of constructing a coherent interpretation of the text through the use of theme, and they also applied these themes to discuss rather than to present facts. Art students also thematized other writers in their essays much more than that presented in the essays written by science students who tended to make more use of unqualified assertions (North, 2005). She concluded that in essay writing, thematic choices reflect the different conceptions of knowledge of academic writing, and this could be a factor in grade achievement in course assessment.

The positive points of North's (2005) study were a) the gained result was generalizable because it was based on the analysis of large corpus, b) all the steps of her study was scientifically backed and rationalized, c) the t-unit (independent clause and its dependent clause or clauses) was used as a unit of analysis, d) the result was explained thoroughly and supported by examples from the analyzed data, and e) the result was statistically meaningful since it was compared and contrasted with other studies. The shortcomings of this study were a) it focused only on thematic organization while thematic progression was neglected, and b) subcategories of thematic organization types were not taken into consideration in this study.

Cross-linguistic studies on theme

The cross-linguistics studies on theme presented in this section concerns theme manifestation in different genres of textbooks, research articles, and advertisement texts across two different languages.

Ghabanchi (1990) performed a contrastive analysis of the target sentences of English and Persian texts. The corpus used in his study consisted of 40 short English and Persian texts written for beginners by native speakers. The total number of the English sentences were 237, and that of Persian sentences were 315. The English texts were drawn from the book *Practice and Progress* and the Persian texts were selected from *Taalimat Dini*, and *Farsi*

Reading for second to fifth grades of elementary school. He found three types of theme-rheme structures existing in his data: a) the first type indicates the simultaneous relationship between theme and rheme of one sentence with theme and rheme of the subsequent one; b) the second type is theme omission which exists in Persian texts, and c) the third type indicates the relation of the preceding theme to the subsequent rheme which was rare in both languages. Findings showed that most of the common references to theme in English were pronouns whereas in Persian most of the common references to theme were pronouns and synonyms.

The positive points of this study were: a) the result was built on a big corpus which supports the result generalization, and b) the result is meaningful since it was compared and contrasted with other earlier studies, and c) it focused on both thematic organization and thematic progression. The shortcoming of this study was that the two texts were not linguistic realizations of the same idea in two languages like that in translation.

Williams (2005) performed the analysis of thematic types referring to research and researchers reported in the discussion section of Spanish Biomedical articles and English-Spanish translation. The corpus used in his study contained approximately half a million words and consisted of 192 research articles following the introduction, method, result, and discussion (IMRD) format. The results showed that in the Spanish texts most of the themes referred to the researcher whereas the themes in the translation referred mostly to the research.

The positive points of this study were a) the corpus is large enough to be representative of the analyzed field, and b) the result is generalizable since it was based on a large corpus. The shortcomings of this study were a) the study focused on only the discussion section of the research article, and b) only one theme type was analyzed.

Zhou (2006) applied the theme construction to the Chinese language which shows some grammatical dissimilarity when compared to English. She worked on interpersonal metafunction and attempted to show whether advertisement texts engender similarities in interpersonal metafunction. She selected 15 texts from 2 Chinese journals and 15 from 2 English journals. The Hallidian theme categories (1985) and the interpersonal theme categories were taken into account. The themes were counted and classified accordingly. Results showed that the modal themes were not prevalent across both corpora, and he concluded that the advertisement texts did not engender similarities in interpersonal metafunction across two languages.

The positive point of this study was the sufficient size of the corpus for generalizing the result, and the shortcoming was the focus on only one of the three metafunction of the language proposed by Halliday.

In their study on thematic organization and progression, Jalilifar and Khedri (2011) analyzed thematic structure of English academic texts and their translations in Persian. They ran their study on a corpus of sample academic texts selected from the first three pages of the first chapters of 9 English

applied linguistics textbooks and their translated versions. These textbooks were representing applied linguistics textbooks used to teach B.A. and M.A. students in Iranian universities and their parallel translated into Farsi. They used Halliday's (1994) model of thematic organization and McCabe's (1999) model of thematic progression. They used the t-unit as unit of analysis. The result showed differences regarding thematic organization types and progression patterns in both textbooks. As for thematic organization, the result showed significant difference in terms of the textual, multiple, and marked themes. In the case of thematic progression patterns the result showed significant differences between the linear, constant and miscellaneous patterns. The study concluded that both authors as well as translators must be conscious of these tools in order to use them effectively and create more cohesive texts.

This study had the following positive points: a) the study was ran on a large enough corpus for result generalization, b) the study analyzed the same idea presented in two different languages; controlling idea as a variable would mean that the differences or the similarities would be attributed more directly to thematic structure differences, c) the unit of analysis was the t-unit, d) the result was meaningful since it was compared and contrasted with earlier ones, e) the result were supported with description, discussion and exemplifications, f) all the steps of this research was rationalized and scientifically backed, and g) both thematic organization and progression as well their sub-categories

were analyzed. The drawback of this study was the focus on only the first chapter of textbooks; therefore, the data is not representative of the entire text.

CONCLUSION

In sum, the reviewed studies which focused on thematic structure application across disciplines, showed several shortcomings and strengths (The main findings of this review are presented in Appendix B). Nonetheless, they supported what was earlier suggested by North (2005) and Lovejoy (1991), that writers from different disciplines write differently since each discipline as a small discourse community has its own specific expectations, beliefs, and practices which is shared among its members (Lovejoy, 1991). Writing in each discipline is affected by the discipline conventions, and shaped by disciplinary background (North, 2005).

Despite some shortcomings, the reviewed studies regarding theme application across different linguistics (The main findings of this review are presented in Appendix B) supported what was suggested and claimed earlier by Ventola (1995) and Matthiessen (2004). Ventola states that there is no question about the usefulness of thematic structures in text construction, but this structure is not expected to function in the same way in various languages (1995, p.102). In the same line of argumentation, Matthiessen (2004) suggests that research has shown that thematic structure (thematic organization and progression) is not quite the same among various languages.

SUGGESTIONS FOR FURTHER RESEARCH

This paper that aims at reviewing related studies concerning thematic structure application across different disciplines and linguistics illuminates a number of areas for further research. As the reviewed studies were mostly on research articles and textbooks, a more insightful picture of cross-disciplinary and cross-linguistic manifestations of theme could be obtained through the analysis of other genres such as newspapers, e-mails, academic lectures, and literature texts. The reviewed research articles were mostly ran on small corpora where results are not statistically significant enough for generalization, so further studies on theme use bigger corpora are needed. Many of the reviewed research articles targeted only thematic organization or thematic progression, so further studies which analyze both structures can help to show the impact of theme as a device in text cohesion.

REFERENCES

- Belmonte, I. A., & McCabe, A. M. (2000). Theme, transitivity and cognitive representation in Spanish and English written texts. Retrieved from: <http://www.ucm.es/info/circulo/no7/mccabe.htm>
- Brown, G., & Yule, G. (1983). *Discourse analysis*. Cambridge: Cambridge University Press.
- Creswell, J. (1994). *Research design qualitative and quantitative approaches*. Thousand Oaks: Sage Publication.
- Ebrahimi, S. F., & Khedri, M. (2011). Thematicity in research article abstracts: A cross disciplinary

- study. *Educational Quest, International Journal of Education and Applied Science*, 2(3), 1-6.
- Fries, P. H. (1992). Theme and new in written English. Retrieved from [http : // Google /Functional Approach/ Section 17.htm](http://Google/Functional Approach/Section 17.htm).
- Ghabanchi, Z. (1990). *Theme/rheme analysis of English and Persian texts in contrast*. (Unpublished master thesis). Tarbiat Modares University Press, Tehran.
- Ghadessy, M. (1999) . Thematic organization in academic articles abstracts. *Estudios Ingleses de la Universidad Complutense* , 7, 141-161 .
- Gosden, H. (1992). Discourse functions of marked theme in scientific research articles. *Journal of English for Specific Purposes*, 11, 207-224 .
- Halliday, M. A. K. (1985) . *An Introduction to functional grammar*. London: Britain: Edward Arnold.
- Halliday, M. A. K. (1994). *An introduction to functional grammar* (2nd ed.). London: Britain Edward Arnold.
- Halliday, M. A. K. (2004). *An introduction to functional grammar* (3rd ed.). London: Britain Edward Arnold.
- Idding, J. (2008). A functional analysis of English Humanities and Biochemistry writing with respect to teaching university composition. *Journal of Novitas-ROYAL*, 2(1), 60-78.
- Jalilifar, A. R. & khedri, M. (2011). Thematic development in English and translated Academic text. In A. R. Jalilifar and E. Abdollahzadah (Eds.), *Academic research genre in Asian context* (pp. 335 – 364). Ahwaz: Shahid Chamran University Press.
- Leonard, D., & Huraki, T. (2005). *Textual organization of academic writing*. Paper presented at the CATESOL State Conference, Los Angeles: University of California.
- Lovejoy, K. B. (1991). Cohesion and information strategies in academic writing: Analysis of passages in three disciplines. *Journal of Linguistics and Education*, 3, 315-343.
- McCabe, A. M. (1999). *Theme and thematic patterns in Spanish and English history texts*. Retrieved from [http: // www. wagsoft.com/systemics/ archive/McCabe.phd](http://www.wagsoft.com/systemics/archive/McCabe.phd)
- McCarthy, M. (1991). *Discourse analysis for language teachers*. Cambridge: Cambridge University Press.
- Matthiessen, C. (2004). Descriptive motifs and generalizations. In A. Caffarel . , J. R. Martin. , and C. Matthiessen (Eds.), *Language functional perspective* (pp. 537-673). Amsterdam: John Benjamins.
- Matthiessen, C., & Halliday, M. A. k. (1997). Systemic functional grammar: A first step into the theory. Retrieved from: [http:// SFG intro \(peng chapter\) New.htm](http://SFG intro (peng chapter) New.htm).
- North, S. (2005). Disciplinary variation in the use of theme in undergraduate essays. *Journal of Applied Linguistics*, 26(3), 1-18 .
- Ventola, E. (1995). Thematic development and translation. In M. Ghadessy (Eds.), *Thematic development in English text* (pp. 85-104). London: Pinter.
- Whittaker, R. (1995). Theme processes and the realization of meaning in academic articles. In M. Ghadessy,(Eds.) *Thematic development in English text* (pp. 105 – 128). London : Pinter
- Williams, I. A. (2005). Thematic items referring to research and researchers in the discussion section of Spanish biomedical articles and English-Spanish translation. *International Journal of Translation*, 51 (2), 124-160.
- Zhou, Y. (2006). The interpersonal metafunction and theme in English and Chinese advertisement texts. *US-China Foreign Language*, 4 (5), 46-50.

APPENDIX A

Summary of Reviewed Studies

Author	Study	Corpus	Method of analysis	Findings
Ghaddesy (1999)	Cross-disciplinary	150 research article abstracts from 30 disciplines	Halliday (1994)	Theme manifest differently across different disciplines
Whittaker (1995)	Cross-disciplinary	8 research articles, 4 from economics and 4 from applied linguistics	Halliday (1994)	Disciplinary differences between the two disciplines in terms of ideational theme and its process
Ebrahimi & Khedri (2011)	Cross-disciplinary	10m research article abstracts, 5 from Chemistry and 5 from Applied Linguistics	Halliday (1994) and McCabe (1999)	Disciplinary difference between two disciplines in case of textual , interpersonal , linear and constant themes
Idding (2008)	Cross-disciplinary	6 texts , 3 from English Humanities and 3 from Biochemistry	Halliday (1994)	Disciplinary difference in terms of interpersonal and unmarked themes
North (2005)	Cross-disciplinary	61 essays, 33 were written by 10 students with art background and 28 were written by 10 students with science background	Mauranen (1993)	Thematic choices in students' essays is shaped by students background
Ghabanchi (1990)	Cross-linguistic	40 short English and Persian texts written for the beginners by the native speakers	Halliday (1985)	Difference between the way theme is manifested in the two languages of English and Persian
Williams (2005)	Cross-linguistic	192 Spanish Biomedical and English-Spanish research articles with IMRD format	Halliday (1985)	Spanish texts had more integral references and more general researchers nouns in their themes whereas the translation had more singular nouns associated with more propositional adjunct in Spanish texts but with more subject themes in the translation
Zhou (2006)	Cross-linguistic	15 texts from 2 Chinese journals and 15 texts from 2 English journals	Halliday (1985)	Modal theme were not prevalent across both corpora, so the advertisement texts did not engender similarities in interpersonal metafunction across two languages
Jalilifar & Khedri (2011)	Cross-linguistic	9 English applied linguistics textbooks and their translation versions	Halliday (1994) and McCabe (1999)	Difference between two textbooks in case of textual, multiple, marked, linear and constant, and miscellaneous themes types and patterns

APPENDIX B

Main Findings of the Reviewed Studies

	Study both thematic organization and progression	Unit of analysis	Analytical Framework	Corpus	Discussion and findings exemplification	Comparing and contrasting the findings with earlier ones
Ghaddesy (1999)	x	x	✓	x	x	x
Whittaker (1995)	x	✓	✓	x	✓	x
Ebrahimi & Khedri (2011)	✓	✓	✓	x	x	✓
Idding (2008)	x	x	✓	x	x	x
North (2005)	x	✓	✓	✓	✓	✓
Ghabanchi (1990)	✓	✓	✓	✓	✓	✓
Williams (2005)	x	x	✓	✓	x	✓
Zhou (2006)	x	x	✓	✓	✓	x
Jalilifar & Khedri (2011)	✓	✓	✓	x	✓	✓



Short Communication

The Relationship between Religiosity and Happiness among Students in an Iranian University

Ali Asghar Bayani

Department of Psychology, Azadshahr Branch, Islamic Azad University, Azadshahr, Iran

ABSTRACT

This study examined the relationship between religion and happiness as espoused by 358 undergraduate Iranian Muslim students (165 men, 193 women). Participants completed Farsi versions of the Oxford Happiness Inventory, the Depression-Happiness Scale and the Religious Orientation Scale. Analysis confirmed a significant positive association between religion and happiness among the sample of Iranian Muslim students. Scores on the Religious Orientation Scale were significantly related to those on the Oxford Happiness Inventory ($r = 0.34, P < .001$), as were scores with the Religious Orientation Scale and the Depression-Happiness Scale ($r = 0.29, P < .001$).

Keywords: Happiness, religion, university students

INTRODUCTION

In recent decades, there has been growing interest in the positive aspects of psychological functioning, which consists of psychological well-being, subjective well-being, satisfaction with life and

happiness. (Diener, 1999; Keyes, Shmotkin, & Ryff, 2002; Seligman, 2002; Aspinwall & Staudinger, 2003; Carr, 2004; & Snyder & Lopze, 2006). Psychological well-being is a complex construct involving both positive and negative effects (Diener *et al.*, 1999).

The relationship between religion and psychological well-being and physical health has been investigated within and outside of the psychology of religion. Empirical research of religion and mental health includes epidemiologic studies

ARTICLE INFO

Article history:

Received: 7 March 2013

Accepted: 16 April 2014

E-mail address:

aliasghar.bayani@gmail.com (Ali Asghar Bayani)

involving community samples, clinical studies and social and behavioral studies on psychological distress and subjective well-being (Levin, 2010).

The positive impact of religion on mental and physical health has been reported in numerous studies. Some studies have found no association between religion and physical or mental health (Crawford, Handal, & Weiner, 1989; Williams *et al.*, 1991; Lewis *et al.*, 1996; Thoresen, 1999; Koenig *et al.*, 2001; Francies & Kaldor, 2002; Miller & Thoresen, 2003; O'Connor *et al.*, 2003; Francies, Robbins, Lewis *et al.*, 2004; Pargament *et al.*, 2005; Hicks & King, 2008). Many of these studies, however, explored the impact of religious attitudes on psychiatric and mental health outcomes in population, community and hospital samples, such as depression, anxiety and levels of psychological distress.

Religion is as old as man and dates back to the appearance of the first man on the planet (Zagzebski, 2007). Religious practices and beliefs have a main and dominant role in the life of people everywhere in the world (Koenig & Larson, 2001). Furthermore, religion is considered a multidimensional concept (Zinnbauer & Pargament, 2005). The two important approaches that are applied in the definition of religion are substantive and functionalist (Clack & Clack, 2008).

Religious orientations are the key component of religious life and include the extent to which one adheres to a belief system and the importance of religion in the individual's life (Evans *et al.*, 2010).

Religion is composed of beliefs and behaviours with a moral part (Young & Koopsen, 2005). According to Allport, commitment to religious beliefs can help organise and give constructive meaning to human life (Ryckman, 2008).

Happiness, like religion, has been taken into account as a multidimensional concept that comprises emotional and cognitive components (Hills & Argyle, 2001; Diener *et al.*, 2003). Argyle (2001) proposed that the concept of happiness comprises (1) average satisfaction over a certain period; (2) frequency and amount of positive effect or joy; and (3) the relative absence of negative effect such as depression and anxiety. Numerous variables have been studied in relation to happiness including gender (eg. Mahon *et al.*, 2005), locus of control (Boschen, 1996; Kelley & Stack, 2000), socio-economic status (Vera-Villaruel *et al.*, 2012) and self-esteem (Lyubomirsky *et al.*, 2006).

There has been growing interest in examining the relationship between religion and happiness in the psychology of religion (see Lewis & Cruise, 2006). Many studies have examined the relationship between religion and happiness within the Christian population and a number of these investigations have employed the Francis Scale of Attitude toward Christianity (Francis & Stubbs, 1987), the Oxford Happiness Inventory (Argyle *et al.*, 1989) and the Depression-Happiness Scale (McGreal & Joseph, 1993). Considering the relationship between religion and happiness, a significant positive association has been

reported by Robbins and Francis (1996), Francis and Lester (1997), Francis and Joseph (1999), Francis and Robbins (2000), Francis *et al.*, White (2003), Abdel-Khalek (2008) and Abdel-Khalek and Lester (2009). In contrast, some studies did not report any significant correlation (Lewis *et al.*, 2000, Francis *et al.*, 2003; Lewis, Maltby, & Day, 2005).

The positive effect of religion on happiness stems largely from the sense of meaning and purpose that religiosity provides to the individuals (Diener *et al.*, 2009). Religious orientation, however, provides an all-inclusive set of meanings and values for interpretation of human events (Colón-Bacó, 2010). Researchers have also examined the relationship between religion and well-being in Muslim samples (Suhail & Chaudhry, 2004; Baroun, 2006; Noor, 2008; Abdel- Khalek, 2008, 2009). They found that religiosity and well-being were significantly correlated in samples of Muslim subjects too.

Since there is a paucity of empirical studies into student happiness, and the association of religiosity with happiness is rarely studied with regards to Muslim students, the present study can contribute to understanding in this area.

RESEARCH AIMS

The present study attempted to extend or improve upon previous investigation in three ways: First, we wanted to determine the extent to which religion ordination was related to happiness among Muslim students. In addition, we wanted to determine whether

gender differences on each of these measures were present. Finally, we wanted to estimate the internal consistency reliability of the scales in a student sample.

METHOD AND MATERIAL

Participants

Undergraduate students of the Islamic Azad University, Azadshahr branch (193 women, 165 men) took part in this study. The stratified sampling method was used to select participants. The sample represented different fields of study and ethnic groups. Their ages ranged from 19 to 48 ($M=26.2$, $SD=10.2$); 125 were married while 233 were single. They participated voluntarily in this study. All respondents completed a questionnaire booklet containing three self-report measures. The instruments were completed during a class under the supervision of one of the research assistants.

Procedure

Analysis of the data proceeded as follows. We first assessed the internal consistency of the scales. Next, we assessed gender differences on any of the instruments. Finally, we investigated the relationship between the religion orientation and happiness.

Measures

Oxford Happiness Inventory (Argyle, Martin, & Crossland, 1989): We used the Farsi version of the Oxford Happiness Inventory (Alipour, Nourbala, Ejei, & Motieyan, 2000). This instrument contains 29 multiple-choice items. Participants

choose one of four sentences that reflect level of happiness from the lowest (*I do not feel happy*) to the highest (*I feel extremely happy*). The Persian version of the Oxford Happiness Inventory had adequate internal consistency with a Cronbach's Alpha of 0.93 and a test-retest reliability coefficient of 0.80. (Bayani, 2008).

Depression-Happiness Scale (McGreal & Joseph, 1993): This is a 25-item instrument designed to measure positive effects. It contains 12 items concerned with positive feelings and 13 items concerned with negative feelings. We used the Farsi version of the Depression-Happiness Scale (Bayani, 2006). Bayani (2006) validated the Depression-Happiness Scale on a sample of 109 men and women and found internal consistency with a Cronbach's Alpha of 0.93 and test-retest reliability coefficient of 0.73.

The Persian version of Religious Orientation Scale (Bahramiahsan, 2001): This is a 45-item Likert instrument dealt with orientation towards Islam. The Persian version of the Religious Orientation Scale had adequate internal consistency with a Cronbach's Alpha of 0.85 (Bahramiahsan, 2001).

RESULTS

Table 1 shows values of the coefficient alpha and the mean scores for men and women in the Oxford Happiness Inventory, the Depression-Happiness Scale and the Religious Orientation Scale.

As Table 1 shows, the internal consistent reliability estimates for all of the scales are acceptable and quite good. The coefficient

alphas were 0.88 for Religious Orientation Scale, 0.91 for the Oxford Happiness Inventory and 0.90 for the Depression-Happiness Scale. An independent sample *t*-test showed that males scored significantly higher than females in the Depression-Happiness Scale ($t=3.69, p<0.001$) and the Oxford Happiness Inventory ($t=5.35, p<0.001$). There is no significant difference between males and females in the Religious Orientation Scale.

Table 2 shows the Pearson correlations between scores on each of the measures. Scores on the Religious Orientation Scale were significantly related to those on the Oxford Happiness Inventory ($r = 0.34, P < .001$), as were scores with the Religious Orientation Scale and the Depression-Happiness Scale ($r = 0.29, P < .001$). A significant positive correlation has been found between the scores on the Oxford Happiness Inventory and the Depression-Happiness Scale ($r = 0.80, P < .001$).

DISCUSSION AND CONCLUSION

In recent years, interest in understanding the effects of religion on psychological well-being has grown in the area of psychology of religion. Therefore, the main purpose of present study was to examine the relationship between happiness and religious orientation in a sample of undergraduate Muslim students.

Regarding the relationship between religion and happiness in Christian samples, previous studies yielded inconsistent findings (Robbins & Francis, 1996; Maltby & Day, 2005). In this study, two Persian

TABLE 1
Mean Standard Deviation and Internal Consistency of Scale by Scale

Scales	α	Men (n=165)		Women (n=193)		t
		M	SD	M	SD	
Religious Orientation Scale	.88	89.49	7.73	88.24	9.06	1.38
Oxford Happiness Inventory	.91	53.32	15.63	44.86	14.25	5.35*
Depression-Happiness Scale	.90	49.85	16.23	47.10	11.87	3.69*

Note.-* $P < .001$

TABLE 2
Pearson Correlation Matrix for Total Scale

Scales	Total (n=358)			Men (n=165)			Women (n=193)		
	1	2	3	1	2	3	1	2	3
1.ROS									
2. OHI	.34*			.36*			.32*		
3. DHS	.29*	.80*		.33*	.81*		.27*	.79*	

Note. – ROS= Religious Orientation Scale; OHI= Oxford Happiness Inventory; DHS= Depression-Happiness. Scale; $P < .001$

versions of most commonly used happiness scales (the Oxford Happiness Inventory and the Depression-Happiness Scale) were employed. Analysis indicated a positive association between religion and happiness, which was in line with the previous results reported by Robbins and Francis (1996), Francis and Lester (1997), Francis and Joseph (1999), Francis and Robbins (2000), Francis, Robbins and White (2003), Abdel-Khalek (2008) and Abdel-Khalek & Lester (2009), although it is noteworthy that the identified relationship in the present study was higher than values obtained in many of the previous studies.

Contrary to Argyle and Hills (2000), Lewis, Maltby and Burkinshaw (2000), Francis, Ziebertz and Lewis (2003) and Lewis, Maltby and Day (2005), we found a significant positive association between religion and happiness in a sample of

undergraduate Muslim students. Research results indicated there were differences in happiness according to gender between male and female students. Male students tended to show greater happiness than female students. In most findings, however, women consistently report more negative emotions than men (Tesch-Romer *et al.*, 2008).

The present study provides further support for the validity and reliability of the Oxford Happiness Inventory, the Depression-Happiness Scale and the Religious Orientation Scale in a student sample. This finding is consistent with results reported by Bayani (2008), Bayani (2006) and Bahramiahsan (2001). Several research studies, including the current study, conclude that religion plays a major role in human life and happiness. We found that there is a relationship between self-rating of religiosity and happiness.

A few limitations need to be considered when interpreting the results of this study. The sample was selected from only one university. This sample may not be representative of all students in Iran. Research participants were a random sample of Iranian students. Thus, the findings may not generalise to students in other countries.

Although research on the relationship between religion and happiness has accumulated considerable literature, there exists a need for cross-cultural studies to determine the effect of religious ordination on happiness in different cultures.

REFERENCES

- Abdel-Khalek, A. M. (2008). Religiosity, health, and well-being among Kuwaiti personnel. *Psychological Reports, 102*, 181-184.
- Abdel-Khalek, A. M., & Lester, D. (2009). A significant association between religiosity and happiness in a sample of Kuwaiti students. *Psychological Reports, 105*, 381-382.
- Alipouar, A., Nourbala, A., Ejei, J., Motieyan, H. (2000). Happiness and body immunology performance. *The Journal of Psychology, 4*, 133-153.
- Argyle, M. (2001). *The psychology of happiness*. London: Rutledge.
- Argyle, M., Martin, M., & Crassland, J. (1989). Happiness as a function of personality and social encounters. In J. P. Forgas & J. M. Innes (Eds.), *Recent advances in social psychology: An international perspective*. North-Holland: Elsevier. pp. 189-203.
- Aspinwall, L. G., & Staudinger, U. M. (2003). *A psychology of human strengths: Fundamental questions and future directions for positive psychology*. Washington, DC: American Psychology Association.
- Bahramiahsan, H. (2001). Preliminary study of validity and reliability of Religious Orientation Scale. *Journal of Psychology and Education, 6*, 67-90.
- Baroun, K. A. (2006). Relations among religiosity, health, happiness, and anxiety for Kuwaiti adolescents. *Psychological Report, 99*(3), 717- 22.
- Bayani, A. A. (2006). Study of Persian version of the Depression–Happiness Scale. *Science and Research in Psychology, 29*, 31-40.
- Bayani, A. A. (2008). Test-retest reliability, internal consistency, and construct validity of the Farsi version of the Oxford Happiness Scale. *Psychological Reports, 103*, 139-144.
- Boschen, K. A. (1996). Correlates of life satisfaction, residential satisfaction and locus of control among adults with spinal cord injuries. *Rehabilitation Counseling Bulletin, 39*(4), 120-244.
- Carr, A. (2004). *Positive psychology: The science of happiness and human strengths*. London: Psychology Press.
- Clack, B., & Clack, B. R. (2008). *The philosophy of religion: A critical introduction*. Cambridge: Polity Press.
- Colón-Bacó, E. (2010). The strength of religious beliefs is important for subjective well-being. *Undergraduate Economic Review, 6*(1), 1-27.
- Crawford, M. F., Handel, P. J., & Weiner, R. L. (1989). The relationship between religion and mental distress. *Review of Religious Research, 31*, 16–2.
- Diener, E. (1999). Introduction to the special section on the structure of emotion. *Journal of Personality and Social Psychology, 76*, 803-804.
- Diener, E., Kesebir, P., & Tov, W. (2009). Happiness. In M. R. Leary, & R. H. Hoyle. (Eds.), *Hand*

- book of individual differences in social behavior* (pp. 147- 161). New York: Guilford Press.
- Diener, E., Scollon, C. N., & Lucas, R. E. (2003). The evolving concept of subjective well-being: The multifaceted nature of happiness. *Advances in Cell Aging and Gerontology, 15*, 187-219.
- Diener, E., Suh, E. M., Lucas, R. E., & Smith, H. L. (1999). Subjective well-being: Three decades of progress. *Psychological Bulletin, 125*(2), 276-302.
- Evans, N. J., Forney, D. S., Guido, F. M., Patton, L. D., & Renn, K. A. (2010). *Student development in college: Theory, research, and practice*. San Francisco: John Wiley & Sons.
- Francis, L. J., Kaldor . (2002). The relationship between psychological well-being and Christian Faith and Practice in an Australian Population Sample. *Journal for Scientific Study of Religion, 41*, 179-184.
- Francis, L. J., & Lester, D. (1997). Religion, personality and happiness. *Journal of Contemporary Religion, 12*, 81–86.
- Francis, L. J., Robbins, M. (2000). Religion and happiness: A study in empirical theology. *Transpersonal Psychology Review, 4*, 17-22.
- Francis, L. J., Robbins, M., Lewis, C. A., Quigley, C. F., & Wheeler, C. (2004). Religiosity and general health among undergraduate students: A response to O'Connor, Cobb, and O'Connor (2003). *Personality and Individual Differences, 37*, 485-494.
- Francis, L. J., Robbins, M., & White, A. (2003). Correlation between religion and happiness: A replication. *Psychological Reports, 92*, 51–52.
- Francis, L. J., & Stubbs, M. T. (1987). Measuring attitudes towards Christianity: From childhood to adulthood. *Personality and Individual Differences, 8*, 741–743.
- Francis, L. J., Ziebertz, H. G., & Lewis, C. A. (2003). The relationship between religion and happiness among German students. *Pastoral Psychology, 51*, 273–281.
- Francis, S., & Joseph, S. (1999). Religiosity and its association with happiness, purpose in life, and self-actualization. *Mental Health, Religion and Culture, 2*, 117–120.
- Hicks, A. J., & King, A. L. (2008). Religious commitment and positive mood as information about meaning in life. *Journal of Research in Personality, 42*, 43-57.
- Hills, P., & Argyle, M. (2001). Emotional stability as a major dimension of happiness. *Personality and Individual Differences, 31*, 1357-1364.
- Kelley, T. M., & Stack, S. A. (2000). Thought recognition, locus of control and adolescent well-being. *Adolescence, 35*(139), 531-551.
- Keyes, C. L. M., Shmotkin, D., & Reff, C. D. (2002). Optimizing well-being: The empirical encounter of two traditions. *Journal of Personality and Social Psychology, 82*, 1007–1022.
- Koenig, H. G., & Larson, D. B. (2001). Religion and mental health: Evidence of association. *International Review of Psychiatry, 13*, 67-78.
- Koenig, H. G., McCullough, M. E., & Larson, D. B. (2001). *Handbook of religion and health*. New York: Oxford University Press.
- Levin, J. (2010). Religion and mental health: Theory and research. *International Journal of Applied Psychoanalytic Studies, 7*(2), 102-115.
- Lewis, C. A., Cruise, S. M. (2006). Religion and happiness: Consensus, contradictions, comments and concerns. *Mental Health, Religion and Culture, 9*, 213-225.
- Lewis, C. A., Joseph, S., & Noble, K. E. (1996). Is religiosity associated with life satisfaction? *Psychological Reports, 79*, 429- 430.
- Lewis, C. A., Maltby, J., & Burkinshaw, S. (2000). Religion and happiness: Still no association. *Journal of Beliefs and Values, 21*, 233–236.

- Lewis, C. A., Maltby, J., & Day, L. (2005). Religious orientation, religious coping and happiness among UK adults. *Personality and Individual Differences, 38*, 1193-1202.
- Lyubomirsky, S., Tkach, C., & Dimatteo, R. (2006). What are differences between happiness and self-esteem? *Social Indicators Research, 78*, 363-404.
- Mahon, N. E., Yarcheski, A., & Yarcheski, T. J. (2005). Happiness is related to gender and health in early adolescences. *Clinical Nursing Research, 14*, 175-190.
- McGreal, R., & Joseph, S. (1993). The Depression-Happiness Scale. *Psychological Reports, 73*, 1279-1282.
- Miller, W. R., & Thoresen, C. E. (2003). Spirituality, religion and health: An emerging research field. *American Psychologist, 58*, 24-35.
- Noor, N. M. (2008). Work and women's well-being: Religion and age as moderators. *Journal of Religion and Health, 47*, 476-490.
- O'Connor, B. D., Cobb, J., & O'Connor, C. R. (2003). Religiosity, stress and psychological distress: No evidence for an association among undergraduate students. *Personality and Individual Differences, 34*, 211-217.
- Pargament, K. I., Murray-Swank, N. A., & Tarakeshwar, N. (2005). An empirically based rationale for a spiritually-integrated psychotherapy. *Mental health, Religion & Culture, 8*, 155-165.
- Robbins, M., & Francis, L. J. (1996). Are religious people happier a study among undergraduates. In L. J. Francis, W. K. Kay, & W. S. Campbell (Eds.), *Research in religious education* (pp.207-217). Leominster: Gracwing.
- Ryckman, R. M. (2008). *Theories of personality*. CA: Thomson/Wadsworth.
- Seligman, M. E. P. (2002). *Authentic happiness*. New York: Free Press.
- Snyder, C. R., & Lopze, S. J. (2006). *Positive psychology: The scientific and practical explorations Practical explorations of human strengths*. Thousand Oaks, CA: Sage.
- Suhail, K., & Chaudhry, H. R. (2004). Predictors of subjective well-being in an eastern Muslim culture. *Journal of Social and Clinical Psychology, 23*(3), 359-376.
- Tesch-Romer, C., Motel-Klingebie, A., & Tomasik, M. J. (2008). Gender differences in subjective well-being: Comparing societies with respect to gender equality. *Social Indicators Research, 85*, 329-349.
- Thoresen, C. E. (1999). Spirituality and health: Is there a relationship? *Journal of Health Psychology, 4*, 291-300.
- Vera-Villaruel, P *et al* . (2012). Money, age and happiness: association of subjective wellbeing with socio-demographic variables. *Revista Latinoamericana de Psicolog, 44*(2), 155-163.
- Williams, D. R., Larsun, D. B., Buckler, R. E., Heckman, R. C., & Pyle, C. M. (1991). Religion and psychological distress in a community sample. *Social Science and Medicine, 32*, 1257-1262.
- Young, C., & Koopsen, C. (2005). *Spiritually, health, and healing*. London: Jones and Bartlett Publishers International.
- Zagzebski, L. T. (2007). *Philosophy of religion: An historical introduction*. Oxford: Blackwell.
- Zinnbauer, B. J., & Pargament, K. I. (2005). Religiousness and spirituality. In R.F. Paloutzian, & C.L. Park. (Eds.), *Hand book of the psychology of Religion and spirituality* New York: The Guilford Press. pp. 21-43.

Learning Station Method in Special Education Programs for Students with Learning Disabilities

**Mohd Hanafi Mohd Yasin^{1*}, Hasnah Toran¹, Mohd Mokhtar Tahar¹,
Lokman Tahir² and Suriawati Nawawi³**

¹*Department of Foundations of Education, Faculty of Education, Universiti Kebangsaan Malaysia, 43600 UKM, Bangi, Selangor, Malaysia*

²*Department of Educational Foundation and Social Science Studies, 81310, Skudai, Johor, Malaysia*

³*Ministry of Education Malaysia*

ABSTRACT

This study is to determine the effectiveness of the Learning Station Method (LSM) in the Special Education Programme for students with learning disabilities. LSM is a teaching and learning method equipped with effective teaching materials that emphasise 'hands-on experience' and learning through play. This method is an alternative method to the traditional teaching and learning method that is currently being implemented in Special Education Programmes in Malaysia as it provides students with opportunities for experiential learning and is also conducted according to students' individual ability and interests. The objective of this study is to determine the effectiveness of LSM in increasing students' interest in learning, mastery of the skills taught and changes in students' behaviour. This study is quasi-experimental with control and treatment groups, using pre- and post-tests. Sixteen students who were diagnosed with developmental delay were recruited for this study. They were from the Special Education Learning Disabilities Programme in Astana Primary School, Kuching. Data were analysed with SPSS. Research findings showed that LSM was successful in increasing students' interest, mastery of skills taught and positive behaviour.

Therefore, this study will help the Ministry of Education and special education teachers to plan and implement better the Learning Station Method to make it more effective in developing the mental, physical and social skills of students with special needs.

ARTICLE INFO

Article history:

Received: 1 September 2010

Accepted: 14 January 2014

E-mail addresses:

mhmy6365@yahoo.com (Mohd Hanafi Mohd Yasin),

hasnal@yahoo.com (Hasnah Toran),

mokhtar@ukm.my (Mohd Mokhtar Tahar),

lokmantahir@gmail.com (Lokman Tahir),

suraiwati@yahoo.com (Suriawati Nawawi)

* Corresponding author

Keywords: learning disabilities, Learning Station Methods (LSM), learning stations (KSP), teaching using traditional method, process of teaching and learning

INTRODUCTION

The teaching and learning process for students with special needs requires different and appropriate approaches (Jomtien Statement, 2011). Thus, the Ministry of Education has introduced the method of learning stations to increase the teaching skills of special education teachers for learning disabilities students (Manual Book, Station Teaching and Learning Special Education, Learning Problems, Primary School and Secondary School) (2003)

The *Learning Stations Method* is implemented as an alternative teaching method for special needs children based on their capacity and interest. This method provides a more flexible teaching and learning approach that is focused and relevant to the ability of special needs students. The implementation of a special education curriculum enables teachers to modify the methods or techniques of teaching and learning, teaching time and teaching aids to achieve the aims and goals of special education. Through a flexible and integrated process of teaching and learning, it is expected that special education teachers would be able to produce independent, disciplined, productive special needs individuals who display a positive attitude and can contribute to their family, community and country.

In addition, the LSM allows students to use the materials. This situation can motivate them to participate actively in the teaching and learning process. Through it, their self-confidence can be increased, and they will grow to be brave and courageous in facing any challenges and in the future, will be of benefit to community and country.

RESEARCH OBJECTIVES

The main objective of this research is to determine the effectiveness of implementing LSM in Special Education Programmes to focus on students with learning problems. This research also has its specific objectives, which are:

- a. To determine students' interest in order to decide whether to use LSM or traditional methods in learning Art Education
- b. To determine the changes in behaviour in students taught using LSM teaching compared to traditional teaching
- c. To determine the changes in behaviour in terms of self-management between students who were taught using LSM and those who were taught using the traditional method
- d. To determine students' proficiency skills in the subject of Life Skills between students who were taught using LSM and those taught using the traditional method

LITERATURE REVIEW

The importance of a conducive learning environment has been reported by the Asian

Programme of Educational of Development (APIED, 1983), which identified a number of factors that impaired the effectiveness of a teacher's teaching; they included an ill-equipped physical environment, an imperfect learning climate, teachers who are not interested in teaching and methods that are not engaging and motivating for students. Other factors that hamper learning were identified as lack of resources and unattractive teaching methods. LSM has been designed to overcome such problems associated with teaching and learning, with special focus on students with special needs.

A study by Rounds, Ward, Mergendollar and Tickunoff (1985) found that many students actively participated in various activities at the different learning stations. The study also found that there were more activities conducted in primary schools compared to in secondary schools. This was probably due to the fact that the primary level requires diversity in order to attract and hold the attention of students with learning disabilities, especially those who have had no preparation to study.

The stations method was also used in the teaching and learning of reading for students of special rehabilitation who were weak in reading. A study by the Ministry of Education (2011) on the effectiveness of the reading stations method for students weak in reading proved that the stations method was able to improve reading skills of a target group. Using this method resulted in the target group feeling that they were more appreciated and this indirectly raised their self-confidence. A livelier teaching and

learning environment that catered for their different levels of reading control evidently led students to respond positively.

The findings of Philips, Noor Aini Ahmad, Abd. Rahim Razali, Kamaliah Muhamad and Md. Fawzi Yusuf (2005) showed a positive response to the implementation of learning stations in the Special Programme for Learning Disabilities in primary school. This is relevant because the good implementation of the learning stations method allows for more structured and comprehensive learning. Previous studies clearly show that environment, such as layout and classroom climate, also plays an important role in increasing the interest of students with learning disabilities in the process of teaching and learning (Mohd Hanafi Mohd Yasin, Hasnah Toran, Ainul Azmin Mohd Zamin & Lokman Tahir, 2012).

RESEARCH METHODOLOGY

This research was a quasi-experimental design which involved a pre-test and post-test treatment group and control group. This study used simple random sampling. Samples were selected from students with late development or those classified as Slow Learner in the Special Programme of the Sekolah Kebangsaan Astana, Kuching. Although the ages of the respondents in the samples differ, there is little difference between them in terms of cognitive ability. The control group consists of students from Special Programmes for Learning Problems (Program Khas Bermasalah Pembelajaran) whose traditional methods. Both groups

were given a pre-test in the first week. The duration of the treatment was six weeks i.e. from week two to week seven. The post-test was conducted in the eight week in order to see an increase in the mean score.

Data Collection

Before starting data collection, a pilot study was conducted to see the suitability of the observation instrument for fixed skills. The researcher obtained permission from EPRD (Educational Planning Research Division, Ministry of Education) and approval from the State Education Department of Sarawak to conduct research at Sekolah Kebangsaan Astana, Kuching. Three stages of data collection were conducted to achieve the objectives. The first stage was the pre-test that was conducted in early March. The second stage was the six-week treatment. The treatment was conducted from the third week of March till the first week of May. The final stage of data collection was conducted in the second week of May.

Data Analysis

Descriptive and inferential statistics were used to analyse the data. Descriptive statistics was used to analyse data that related to the respondent’s demographics. Mean and percentage scores obtained from the analysis were presented in tables and graphs. A *t*-test was used to show the difference between the mean scores for the pre-test and post-test and to analyse the post-test increment between both groups. All the data were analysed using SPSS.

FINDINGS

There were 16 students who involved in this research, of whom 11 were male students (68.8%) and 5 were female students (31.2%). The number of students in the experimental and control group was the same i.e. 8 members per group. There were 5 respondents (31.3%) from the ages of 8-10 years old, 9 (56.2%) from 11-13 years old and 2 (12.5%) from 14-16 years old. These respondents came from two different ethnic backgrounds i.e. Malay and Iban. Nine respondents were Malay (56.2%) and 7 were Iban (43.8%).

Comparison Between the Treatment Group and the Control Group Regarding the Test of Students’ Interest in Art Education

The mean score of the pre-test for the treatment group was 2.76 (n=8. SD=.46) and the mean score for the control group was 2.50 (n=8, SD=.95). The difference between the experimental and control group is small and it is accurate with the *t*-test result $t = .70$ and $p = .491 > 0.05$. Therefore, there is no significant difference in interest between using LSM and traditional methods. In general, students in the treatment group and control group showed a similar performance during pre-test.

TABLE 1
Pre-test Result for Students’ Interest in Art Education

Group	n	\bar{x}	SD	<i>t</i>	sig (p)
Treatment Group	8	2.76	.46	70	.491
Control Group	8	2.50	.95		

In the post-test, the mean score for the treatment group was 3.90 (n=8, SD=.50) and the mean score for the control group was 2.79 (n=8, SP=.43). The *t*-test result showed a significant difference between the treatment group and the control group based on the *t*-value=4.7, $p=.00 < 0.05$. This indicated that LSM was suitable in learning art education for children with learning disabilities.

TABLE 2
Post-test Result for Students' Interest in Art Education

Group	n	\bar{x}	SD	<i>t</i>	sig (p)
Treatment Group	8	3.90	.50	4.7	.00
Control Group	8	2.79	.43		

Comparison Between the Treatment Group with the Control -Group Regarding Students' Proficiency Skill in Life Skills

The study found that the mean score of the pre-test for the treatment group was 3.09 higher than for the control group, which was 2.39. The *t*-test value acquired showed insignificant results i.e. $t=2.8, p=12.13 > 0.05$. Therefore, the null hypothesis was not rejected because there was no significant difference in mean proficiency between the treatment group and the control group that used LSM. The LSM method can, therefore, be implemented as an alternative teaching method for special needs children for teaching Life Skills.

TABLE 3
Pre-test Result for Students' Proficiency Skill in Life Skills

Group	n	\bar{x}	<i>t</i>	sig (p)
Treatment Group	8	3.09	2.8	12.13
Control Group	8	2.39		

In the post-test, the mean score for the treatment group was 3.93 (n=8, SD=.53) higher than for the control group, which was 2.95 (n=8, SD=.49). The *t*-test result showed a significant difference with the *t*-value=3.8, $p=.002 < 0.05$. Therefore, the null hypothesis was rejected. The findings showed that LSM had a direct impact on control skill in Life Skills compared to traditional methods.

TABLE 4
Post-test Result for Sudents' Proficiency Skill in Life Skills

Group	n	\bar{x}	<i>t</i>	sig (p)
Experimental Group	8	3.93	3.8	.002
Control Group	8	2.95		

Comparison Between the Treatment Group with the Control Group Regarding Students' Behaviour in Self-Management

The mean score of the pre-test for the treatment group was 3.23 (n=8, SD=.54) and for the control group was 2.90 (n=8, SD=.44). The *t*-test result was $t=1.3, p=.209 > 0.05$. Therefore, the null hypothesis was rejected because there was no significant difference in performance skills between the treatment group and control group.

TABLE 5
Pre-test Result for Changes in Students' Behaviour in Self-Management

Group	n	\bar{x}	<i>t</i>	sig (p)
Treatment Group	8	3.23	1.3	.209
Control Group	8	2.90		

After treatment, the mean score for the treatment group was found to be 4.07 (n=8, SD=.51) higher than for control group i.e. 3.70 (n=8, SP=.62). The difference in mean score between the groups was very small. The

t-test result showed there was no significant difference in behaviour changes as a result of using either LSM or traditional methods as the $t=1.3$, $p=.213 > 0.05$. Therefore, the null hypothesis was not rejected. Students from the treatment and control group who used LSM showed similar performance in Behaviour Management subjects.

TABLE 6
Post-test Result for Changes in Students' Behaviour in Self-Management

Group	n	\bar{x}	<i>t</i>	sig (p)
Experimental Group	8	4.07	1.3	.213
Control Group	8	3.70		

The analysis showed that the students who were taught using the Learning Station Method (LSM) obtained results as follows:

- a. Students who used LSM gained high scores in all observation tests that were conducted. However, the treatment group showed the highest achievement over the control group in the proficiency test in Life Skills and interest tests in Art Education. There was a significant difference in the *t*-test result for students' proficiency skill in Life Skills and students' interest in Art Education compared to that for changes in students' behaviour in Self-Management.
- b. Students had interest in Art Education, behaviour changes in terms of Self-Management and they could master life skills better than those students who used the traditional method.

Overall, the findings of this study succeeded in answering the research questions. Through the *t*-test, two null hypotheses were rejected while one null hypothesis was not rejected. There were significant differences in mastering life skills, students' interest in Art Education and changes in students' behaviour in terms of self-management for students who taught using LSM compared to students who were taught using traditional methods.

CONCLUSION

The Extent of Effectiveness in Implementing the Learning Stations Method (LSM)

This study found that the Learning Stations Method (LSM) was effective compared to the traditional method in improving teaching and learning in the special learning disabilities programme. This is based on the mean results of the observation test conducted, which showed improvement in all three subjects studied. For example, the mean of the proficiency test in Life Skills showed a significant difference; the post-test mean was 3.93 compared to the controlled group mean of only 2.95. The mean of achievement in the test of skills in Art Education for the experimental group recorded a mean of 3.90 compared to the controlled group mean of 2.79 after treatment.

This research finding is in line with that of Philip *et al.* (2005), which explained that LSM provides positive implications for teaching and learning in PKBP in schools.

This is also in line with research by Rounds *et al.* (1985), who found that most special education students actively participated in various activities at the learning stations.

In LSM, a conducive learning environment is emphasised. Thus, these research findings support and strengthen the opinion of the Asian Programme of Educational of Development (1983), Reith and Everton (1988) and Cegelka and Berdine (1995), who reported that the influence of learning comes from environment as well, and this includes the physical environment and the school climate as well as teachers' commitment and the *hands-on experience*.

LSM emphasises learning according to level of ability, intelligence, skills, interests and abilities and also provides opportunities for students to learn through experience and prior knowledge; all this is very helpful in enhancing students' interest and skills. In addition, the angle or space devoted to a particular subject for students and teachers with supporting materials including teaching aids, furniture and equipment according to station is also a contribution in the implementation of LSM in schools.

The Extent of Interests in Students Pursuing the Teaching Using LSM and Traditional Methods

LSM emphasises the student-centred approach in the teaching and learning process. Based on the results of this research, it is believed that LSM can increase students' interest in Art Education, as the mean for the experimental group was 3.90 while for the controlled group it was 2.79. This finding

supports that of the Ministry of Education (2010), Reith and Everton (1988) and Berliner (1983), which showed that various teaching activities like cooperative learning, watching videos, visits, arts and science projects could attract students with learning disabilities to become involved in teaching and learning activities.

This study found that special students showed interest through their interest and hard work in carrying out the arts activities provided. The activities conducted focused on existing experience that could be applied in daily life in order to foster students' interest in performing the given activity. The study also found that special students should be given assignments in accordance with their interests and abilities so that learning becomes fun for them.

The Extent of Proficiency Skills in Students Pursuing the Teaching Using LSM and Traditional Methods

The learning stations method as recommended by the Ministry of Education (2010) was able to attract interest and give students the opportunity to display their skills such as cooking and self-management. For Life Skills, there was a significant difference between students in the two groups. A mean of 3.93 for the experimental group and a mean of 2.95 for the control group showed that the LSM had helped PKBP students to master skills. The study found that the student-centred learning stations provided an opportunity for students to learn through experience as well as gave them the opportunity to conduct practical

training such as preparing a sandwich. These activities allow special students to have learning experience and improve their mastery skills.

This findings of this study are in line with the studies of Zainuddin, Sanitah and Sabilah (2006), which shows that Life Skills provides basic skills to special students in addition to educating them to be independent and to grow into useful citizens. It also helps parents. A conducive learning space and learning through experience clearly can increase students' proficiency. Supported materials in a particular station are also able to help students to master a particular skill more effectively to achieve the objectives of teaching and learning. The research results are in line with the subject's objectives, which are to provide training and skills to enable students with learning disabilities to be independent and confident in carrying out their daily activities (Special Education Curriculum for Learning Problems, 2003).

The Extent of Changes in Behaviour in Students Taught Using LSM and Traditional Methods

The findings of this research suggest that LSM can help students with learning disabilities to achieve behaviour change through learning activities while playing, where students learn a specific new skill that also brings enjoyment to them. LSM has a tendency to create student-centred learning situations. In this study, a mean of 4.07 for the experimental group and a mean of 3.70 for the controlled group in the skill of self-management were recorded, showing that there was a change in behaviour in students

being taught using the LSM compared to students being taught using traditional methods. For students in the category of 'Slow Learner', learning while playing can increase their interest in learning. When interest can be nurtured, it becomes easy for teachers to form the attitudes of their students.

This study found that the special students showed behavioural change when using the toilet, after teachers conducted teaching using supported materials and actual situation. The teachers took students to the toilet and demonstrated how to use the toilet. Afterwards, a significant change in behaviour was shown by students in the practice of hygiene i.e. they washed their hands after using the toilet, as well as informed teachers when going to the toilet. This is in comparison to the traditional method, where teachers only use support material in the form of images rather than real situation. These research findings support the belief of Cegelka and Berdine (1995) that the activity and the physical restructuring of a classroom could influence students' behaviour.

In the special class for learning problems, the space station, layout and equipment in a classroom are very important because they can nurture and develop mental, physical and social skills (Mohd Hanafi Mohd Yasin, Hasnah Toran, Mohd Mokhtar Tahar, Noraini Mohd Salleh, & Rabaishah Azirun, 2011). The use of school equipment such as the school field and toilets can facilitate teaching so that students can easily master the skills taught.

IMPLICATIONS AND RECOMMENDATIONS

It is suggested that the Ministry of Education (2010) build special classrooms to accommodate the special education curriculum for students with learning disabilities. These classrooms should be equipped with furniture and equipment for the creation of learning stations that are suitable for the students in terms of students' physical needs, location and class size. It is recommended that the tools provided also should be suitable for the students.

The Curriculum Development Centre of the Ministry of Education should be more sensitive to the needs of the special education curriculum and should re-evaluate the existing curriculum so that its content is more practical and relevant to the level of students with learning disabilities. The ministry also needs to provide a proper and systematic syllabus so that the teachers can understand and master, and, subsequently, deliver to students effectively. This curriculum should be standardised for use throughout the country so that it can be implemented simultaneously and can be used by each special student with learning disabilities.

The findings of this research are expected to provide guidance for teachers in special schools to help them diversify teaching activities so that they are more student-centred so that students are encouraged to experience the learning process for themselves. In enhancing students' interest in their education, teachers should use appropriate teaching aids and need to be well informed of KSSR .

Special education teachers should be given opportunities to attend long courses in order to refresh and update their knowledge in this field. According to the Educational Planning and Research Division (EPRD, 2002) the teacher factor is one of the reasons for the effectiveness of teaching and learning. Thus, a short course would not help them to gain the experience and knowledge they will need to teach children with special needs. Daut Yusuf (2006) found that most teachers inducted into a special programme of learning problems consisted of mainstream teachers who lacked experience in conducting teaching and learning of special education students. In addition, teachers can also diversify their teaching activities with information obtained from attending special education courses organised by the Ministry of Education.

Placement of special education teachers should use the proper channels. Often different teachers give a different impact on a particular programme. The teacher, therefore, needs to fit the course; in addition, skilled teachers would know the complexity of a problem as well as how to fix it (Mohd Hanafi Mohd Yasin, Noraidah Sahari, & Arbi Haza Nasution, 2013). Passion for special education is another commitment that is needed. Therefore, teacher-training colleges and universities should select students who are capable and who have a love for teaching, especially when it comes to special education.

This study showed that the method of learning stations brings positive change in interest, skills and behaviour of children with special needs. Therefore, it is hoped

that this study will help the Ministry of Education and special education teachers to plan and implement better learning stations so that the implementation of LSM will be more effective for the development of the mental, physical and social needs of students with learning disabilities.

REFERENCES

- Abdul Ghafar Md. Din. (2003). *Prinsip dan amalan pengajaran*. Selangor: Utusan Publications & Distributors Sdn. Bhd.
- Abdul Rahim Selamat & Ismail Hj. Adnan. (1993). *Pustaka sumber dan sekolah, konsep, perancangan & pelaksanaan*. Singapura: Ideal Printing & Paper Products.
- Abdullah Mohd. Nor *et al.* (2000). *Keperluan gaya pembelajaran pelajar dan pencapaian akademik. Seminar Kebangsaan Kepelbagaian pelajar. Fakulti Pendidikan*. (in Bahasa). Universiti Kebangsaan Malaysia. Bangi.
- Ahmad Hazi Ab. Rahman. (1996). *Pembelajaran masteri dan implikasi dari segi kurikulum*. (in Bahasa). Kertas kerja dalam Laporan Bengkel Kebangsaan ke arah Mastery Learning. Pusat Kembangan Kurikulum.
- Anderson, L. W., & Block, J. H. (1991). Mastery learning model in M. J. Dunkin (Ed). *The international encyclopedia of teaching and teacher education*. New York: Pergamon Press.
- Ang Huat Bin. (1999). *Konsep dan kaedah pengajaran dengan penekanan pendidikan inklusif*. (in Bahasa). Kuala Lumpur: Utusan Publications & Distributors Sdn. Bhd.
- Asian Programme of Educational Innovational of Development (APIED). (1983). *Learning needs and problem primary education*. Vol 1 & 11. Bangkok: UNESCO.
- Bahagian Perancangan dan Penyelidikan Dasar Penyelidikan. (2002). *Laporan bahagian perancangan dan penyelidikan dasar pendidikan*. (in Bahasa). Kuala Lumpur: Kementerian Pelajaran Malaysia.
- Berliner, D. C. (1983). Developing conceptions of classroom environments: Some light on the classroom studies of ATI. *Educational Psychologist*. Hlm 1-13
- Cegelka, P. T., & Berdine, W. H. (1995). *Effective instructions for students with learning difficulties*. USA: Simon & Schuster Co.
- Collins, J. E. (1961). *The effects of remedial education. Educational monograph. No.4, University of Birmingham*. Dlm. Syed Abu Bakar Syed Akil. (pnyt.) *Bimbingan khas perkhidmatan pendidikan pemulihan*., pp. 3-21. Selangor: Dewan Bahasa dan Pustaka.
- Culatta, R. A., & Thompkins, J. R. (1999). *Foundamentals of special education*. Boston: Allyn & Bacon.
- Crow, L. D., & Crow, M. A. (1983). *Psikologi pendidikan untuk perguruan*. Terj. Habibah Elias. Kuala Lumpur. Dewan Bahasa dan Pustaka.
- Daut bin Yusuf. (2006). *Perlaksanaan latihan vokasional dalam mata pelajaran Kemahiran Hidup bagi pelajar bermasalah pembelajaran di program khas integrasi Pendidikan Khas Bermasalah Pembelajaran*. (Master dissertation). Fakulti Pendidikan. Universiti Kebangsaan Malaysia.
- Dick, W ., & Reiser, R. A. (1994). *Merancang pengajaran yang efektif*. (trans.) Abd. Rahim Mohd. Saad. Pulau Pinang: Universiti Sains Malaysia.
- Faridah bt Hassan. (2000). *Pembelajaran masteri: Ke arah peningkatan pencapaian, perubahan persepsi, sikap, minat dan motivasi pelajar terhadap mata pelajaran sains*. Universiti Kebangsaan Malaysia.

- Gulliford, R. (n.d.) The child works below his chronological age. *Dlm. Syed Abu Bakar Syed Akil. (pnyt.) Bimbingan khas perkhidmatan pendidikan pemulihan*, pp. 3-21. Selangor: Dewan Bahasa dan Pustaka.
- Ho Sew Ching. (2005). *Program pengurusan tingkah laku untuk murid yang mempunyai kecelaruan kurang daya tumpuan dan hiperaktif (ADHD) di kelas program integrasi Pendidikan Khas Bermasalah Pembelajaran*. (Master dissertation). Fakulti Pendidikan. Universiti Kebangsaan Malaysia.
- Jabatan Pendidikan Khas. (1995). *Perancangan strategik. Pendidikan Khas 2020*. Kuala Lumpur: Kementerian Pendidikan Malaysia.
- Jabatan Pendidikan Khas. (2003). *Buku panduan. Perlaksanaan program pemulihan khas. Masalah penguasaan 3M*. Kuala Lumpur: Percetakan Nasional Malaysia.
- Jabatan Pendidikan Khas. (2003). *Stesen pengajaran dan pembelajaran pendidikan khas Bermasalah pembelajaran sekolah rendah dan menengah*. Kuala Lumpur: Kementerian Pelajaran Malaysia.
- Johnson, J. R., & Johnson, R. (1986). *Mainstreaming and cooperative learning strategies. Exceptional children. Association for supervision and curriculum development*. Alexandria. Va.
- Kamaruddin Hj Husin. (1995). *Dinamika sekolah dan bilik darjah*. (in Bahasa). Petaling Jaya: Utusan Publications & Distributors Sdn. Bhd.
- Kauffman, J. M., & Hallahan, D. P. (2005). *Special education. What it is and why we need it*. United States of America: Pearson Education.
- Kementerian Pendidikan Malaysia. (1982). *Buku panduan am KBSR*. Kuala Lumpur: Pusat Kembangan Kurikulum.
- Khusairi Mustapa. (1993). Proses dan teori bacaan. *Jurnal Gemilang*, 7, 115-125.
- Meningkatkan penguasaan membaca jam waktu dalam kalangan murid-murid pendidikan khas*. Retrieved on July 12, 2007 from <http://www.emoe.gov.my>.
- Mempertingkatkan kemahiran membaca di kalangan murid-murid tahun dua melalui kaedah stesen*. Retrieved on August 18, 2007 from <http://www.emoe.gov.my>
- Mohd. Nasir Mohd. Nor. (2005). *Profil tahap penggunaan komputer dalam pengajaran guru-guru program khas bermasalah pembelajaran di negeri sembilan*. (in Bahasa). Projek Penyelidikan. Fakulti Pendidikan. Universiti Kebangsaan Malaysia. Bangi.
- Mohd. Siraj Awang. (1999). Pendidikan inklusif dan penyediaan guru untuk sekolah-sekolah tempatan. (in Bahasa). *Jurnal Akademik Maktab Perguruan Ilmu Khas*, 14(11).
- Mohd. Najib Ghaffar, & Sanisah Jahaya. (2006). *Bias pengajaran guru dalam pelajaran khas dan pelajaran normal*. Retrieved from http://eprints-utm.my/2236/1/7_9.pdf
- Mohd. Sharani Ahmad. (2004). *Mengurus kanak-kanak yang susah belajar*. Kuala Lumpur. PTS Publications & Distributors Sdn. Bhd.
- Mohd. Zabid bin Omar. (2005). *Perlaksanaan latihan vokasional dalam mata pelajaran kemahiran hidup pelajar khas bermasalah pembelajaran di Negeri Sembilan*. (Project paper, from Master dissertation). Fakulti Pendidikan. Universiti Kebangsaan Malaysia.
- Naina Mohd. Nor. (2001). Pembelajaran efektif melalui pengajaran inovatif. *Diges Pendidikan* 1(1), 31-42.
- Percy, R. L. (1990). The effects of teachers' effectiveness training on the attitudes and behaviors of classroom teacher. *Educational Research Quarterly*, 14, 15-20

- Portal rasmi Jabatan Pendidikan Khas. Retrieved on July 12, 2007 from <http://www.emoe.gov.my/jpkhas>
- Reith, H., & Everton, C. (1988). Variables related to the effective instructions of difficult to teach children. *Focus on Exceptional Children, 10*(5) 1-8.
- Roth, S. C. (1994). *The interactive of leaner, task and setting*. Boston: Allyn & Bacon.
- Rounds, T. S., Ward, B., Mergendollar, J., & Tickunoff. (1985). *Junior high school transition study. Vol. 2. Organisation of instructions*. San Francisco: Far West Lab.
- Rusleeda Awang. (2005). *Hubungan penglibatan ibu bapa dengan pencapaian kanak-kanak prasekolah dalam kemahiran asas membaca*. (Master dissertation). Fakulti Pendidikan Universiti Kebangsaan Malaysia, Bangi.
- Saedah Siraj, Zainun, & Tuanku Mohani Tuanku Moktar. (1996). *Motivasi dalam pendidikan*. Kuala Lumpur: Utusan Publication & Distributions Sdn. Bhd.
- Sharifah Alwiyah Al-Sagoff. (1993). *Ilmu pedagogi pendidikan*. Kuala Lumpur. Heinemann Asia.
- Shahabudin HashimMahani Razali, & Ramlah Jantan. (2004). *Psikologi pendidikan*. Kuala Lumpur. PTS Publications & Distributors Sdn. Bhd.
- Slavin, R. E. (1988). *Cooperative learning and student achievement*. Boston: Educational Leadership.
- Sufean Hussein. (2002). *Kualiti pengajaran-pembelajaran dan keberkesanan sekolah: Pengajaran dan model Penyelidikan. Dlm. Abdul Rahim Abd. Rasyid (pnyt.). Pengajaran dan Pembelajaran Sains Sosial: Teori dan Amalan*. hlm. 23-38. Kuala Lumpur: Penerbit Universiti Malaya.
- Susanna Clare Philips , Noor Aini Ahmad, Abd. Rahim Razali, Kamaliah Muhamad, Md. Fawzi Yusuf. (2005). *Kaedah stesen pembelajaran dalam program pendidikan khas bermasalah pembelajaran*. (Project paper). Jabatan Pendidikan Khas, Universiti Pendidikan Sultan Idris.
- Undang-undang Malaysia. (2003). *Akta Pendidikan 1996 (Akta 550) dan peraturan terpilih*. Petaling Jaya: Internatioanal Law Book Services.
- Wiersma, W. (1991). *Research method in education*. Ed. ke-5. Boston: Allyn & Bacon.
- Yahya Don. (2007). *Kepimpinan pendidikan di Malaysia*. Kuala Lumpur: PTS Profesional Publishing Sdn. Bhd.
- Zarin Ismail, Safani Bari, & Soon Boon Seng. (2004). *Prosiding pendidikan khas. Integrasi sosial murid kerluanan khas*. Fakulti Pendidikan UKM.
- Zainudin bin Mohd. Isa. (1999). *Tinjauan pelaksanaan kurikulum Kemahiran Hidup pendidikan khas bermasalah pembelajaran peringkat menengah di tiga buah sekolah di Wilayah Persekutuan Kuala Lumpur*. (Master dissertation). Fakulti Pendidikan. Universiti Kebangsaan Malaysia.
- Zainuddin et al. (2004). *Pengaplikasian Kemahiran amali dalam mata pelajaran Kemahiran Hidup di dalam kehidupan seharian pelajar pendidikan khas bermasalah pembelajaran di tiga buah sekolah di Johor Baharu*. (Project paper). Fakulti Pendidikan. Universiti Teknologi Malaysia.

Influence of Parents' Jobs on Apprentices' Work Values

Nur Surayyah Madhubala Abdullah*, Chee Chen Soon and Abdul Rahman Md. Aroff

Department of Language and Humanities Studies, Faculty of Educational Studies, Universiti Putra Malaysia, 43400 UPM Serdang, Selangor, Malaysia

ABSTRACT

This paper presents the findings of a study into the relationship between parents' jobs and the work values of apprentices. The findings were examined in the context of the positive relationship between work commitment and productivity of skilled workers and the need to understand influences on the work values of apprentices. The findings showed that the work values of apprentices were influenced by the kind of jobs each parent held. The importance of particular work values to apprentices differed significantly according to either their mother or father's job. ANOVA and Post Hoc analyses showed that the parents' role in their children's work values depended on the work value examined. The findings support literature specifically on intergenerational transmission of values, the occupational linkage hypothesis and the social learning theory on the influence of parents' occupation and children's values. They also show the importance for industry to focus on, and provide support to young apprentices in improving their commitment to work and help raise their productivity levels. The paper offers some suggestions on the kind of focus and support that can be offered.

Keywords: Apprentices, work values, parents' jobs, work commitment, job satisfaction

ARTICLE INFO

Article history:

Received: 19 July 2011

Accepted: 13 March 2014

E-mail addresses:

nsurayyah@upm.edu.my (Nur Surayyah Madhubala Abdullah),

cschee@upm.edu.my (Chee Chen Soon),

rahmanmdaroff@upm.edu.my (Abdul Rahman Md. Aroff)

* Corresponding author

INTRODUCTION

The increasing specialisation and sophistication of industry means that skilled workers are considered valuable assets. However, industries do not only need trained skilled workers but workers who should be able to give their highest commitment towards their work and consequently, their organisations. A high degree of worker

commitment can contribute towards a higher productivity level that embodies a quality of work that satisfies the organisation's needs.

One of the factors that contribute towards higher levels of work commitment among workers and their willingness to demonstrate this commitment in their work is high job satisfaction (Freund, 2005; Petty, Brewer, & Brown, 2005; Ngunia, Slegers, & Denessen, 2006). Indeed, research has shown there is a relationship between organisational commitment, job satisfaction and turnover of workers (Kanwar, Singh, & Kodwani, 2012). Workers who are predicted to leave an organisation are mostly those who are experiencing job dissatisfaction and have attitudes that are related to low work commitment. Absenteeism and tardiness are also found among dissatisfied workers (Wanous & Lawler, 1972; Mitra, Jenkin, & Gupta, 1992; Chen, Chu, & Wu, 2000).

Essentially, job satisfaction is closely related to work values (Kalleberg, 1977; Fabian Jintae Froese & Shufeng Xiao, 2012). In this context, a higher level of correspondence of work values between employers and workers can influence workers' job satisfaction. In turn, it can influence the interest of workers to continue working with their employer. Frone's (2000) interpersonal conflict model shows that young workers' conflict with supervisors has an impact on their sense of job satisfaction. This conflict may stem from differences in work values and differences in the orientation of the importance of work values between workers and their employers.

This study examines the work values of young workers or apprentices. They are usually adolescents or youths. A review of literature on young workers shows their parents' influence on their work values (Dickson *et al.*, 1992; Doepke & Zilibotti, 2005; Bryant, Zvonkovic, & Reynolds, 2006; Dohmen, Falk, Huffman, & Sunde, 2012), their understanding of work (Berti & Bombi, 1988; Abramovitch & Johnson, 1992), and their beliefs and attitudes towards work (Barling, Dupree, & Hepburn, 1998; Barling, Kelloway, & Bremermann, 1991; Dekker, Greenberg, & Barling, 1998; Kelloway, & Newton, 1996; Kelloway & Watts, 1994). Furthermore, studies about generational influences have shown that children whose parents have been involved in specific experiences such as 'downsizing' and 'rightsizing' or who have been fired in the 1980s and 1990s have attitudes and behaviours that reflect attitudes that are "sceptical, unimpressed by authority, and self-reliant" in their orientation towards work do not believe in job stability and demand immediate remuneration in the form of "independence, flexible hours, casual dress, and actually having fun at work" (Jurkiewicz, 2000; Maccoby, 1995; Zemke, Raines, & Filipezak, 2000). One of the implications of parental influence such as this is the effect it has on the adolescent or youth's attitudes about work. For example, Maccoby (1995) and Zemke, Raines and Filipezak (2000) state that the attitudes of workers have changed from a perspective that emphasises "working to live" to

“living to work” based on the experiences of their parents’ whilst growing up. This change in their work orientation suggests that employers should take early steps to intervene and inculcate the work values they want in their workers or to ensure that the orientation and ordering of work values of their workers are as similar as possible to theirs (the employers) to avoid conflicts and confrontations that eventually will affect the workers’ job satisfaction levels and consequently, their overall work commitment. Based on the above literature, this study was carried out to examine the work values of apprentices of a national dual training system, with particular focus on the influence of the parents’ jobs on the apprentices’ work values.

The National Dual Training System (NDTS) is a dual-training apprenticeship system that involves 70-80% training at a partner company and 20-30% training at the NDTS training centre. The aim of the programme is to produce workers based on industry demand, thus reducing the problem of a future mismatch between worker and industry or company. Approaches include self-reliant learning and action-orientated methods to develop apprentices with knowledge-worker occupational competence comprising technical competence, social and human competences and learning and methodological competences. A contract is signed between the company and the apprentices prior to the training. Practical or hands-on skills training is conducted in the workplaces by selected coaches of the company. Theory and basic skills training

is provided by the centre’s instructors. The focus of the training is on the development of young workers; the training requires trainers to infuse or integrate human and social skills in the modules. In addition, the apprentices learn on-the-job skills for the technical contents of the training.

In considering the wider question about the work values of apprentices in this kind of programme, a more specific issue was raised by the researchers as to the kind of relationship that existed between parents’ work values and those of the apprentices. Hence, this study considers the implications of these findings for apprentice preparation specifically in terms of the kind of organisational initiatives that can be offered by coaches/trainers and employers for young workers.

The main theoretical framework used in this study involves two theories. The first theory is the occupational linkage hypothesis that states that there is a relationship between parent’s occupation and occupational values and behaviour of their children. It is based on the ideal that transmission of values and behaviours from parents to children occur in many ways. The second theory is Bandura’s Social Learning Theory, which states that the behaviours and characteristics of children are a product of values modelling by one parent.

Based on the above two theories, this study assumes that work values of apprentices can be influenced by their parents. By identifying the work values of their apprentices and determining whether there are differences in the value priorities

of apprentices according to their father and mother's occupation, employers can identify actions that need to be taken to address any differences that may arise. Hence, the objectives of this study are to identify the work values of apprentices according to their father and mother's occupations and to determine whether there are any significant differences in those values according to their parent's occupation. Based on the findings, suggestions are made on ways employers can address the resulting incongruence in values between coaches/trainers and employers, and young workers.

METHODOLOGY

Study Design

In this study, data on the work values held by the apprentices of NDTs and their mother and father's jobs are compared. The quantitative approach of descriptive survey design is used. Descriptive studies are often used to describe the characteristics of a particular group and to make predictions about particular phenomena (Fraenkel & Wallen, 1993). The data are used to predict whether mother and father's jobs affect apprentices' work values. Specifically, the study describes the differences in work values among apprentices based on their mother and father's job, and examines whether there are significant differences between the two.

Population and Sampling

The target population for this study were apprentices attending training in several

companies and training institutions all over West Malaysia. The process of obtaining the respondents from among these apprentices began with the determination of minimum sample size. Based on the available list until August 28, 2007, 31 companies and institutions had signed up to participate in the training system. Overall, 1,212 people were trained as apprentices in these companies and training institutions. The determination of sample size for quantitative data can be done using several formulas. Among them is the Cochran formula (1978). Based on this formula, the required sample

size is $\frac{t^2 pq}{d^2}$, where the value of t is 1.96, $d = 0.5$, $p = 0.5$, $q = 0.5$. Therefore, the minimum required number of samples is

384. After the correction factor, $n = \frac{n}{1 + \frac{n}{N}}$,

is taken into account, the required number is 365. Therefore, the minimum sample was set as not less than 365 apprentices. In terms of sampling, the apprentices' training locations were divided into four zones: north, central, east and south zones. In order to ensure that the external validity of the study remains high and generalisation of data could be done, the sampling was done using random selection of clusters. One state was randomly chosen from each zone: Kedah for the north zone, Terengganu for the east zone, Selangor for the central zone and Negeri Sembilan for the south zone. Table 1 shows the distribution according to zones: 146 apprentices (30.2%) were from

the middle zone, 141 (29.1%) from the East zone, 110 (22.7%) from the North zone, and 87 (18.0%) from the South zone.

TABLE 1
Distribution of Apprentices According to Zone

Zone	Frequency	Percentage	Cumulative Percentage
Middle	146	30.2	30.2
East	141	29.1	59.3
North	110	22.7	82.0
South	87	18.0	100.0
Total	484	100.0	

Next, a list of institutions and centres that offer training programmes in the selected states were obtained from the Directory of Accredited Centre issued by the Department of Skills Development, Ministry of Human Resources (2006-07). However, several training institutions and companies that could not be involved because of time convergence, lack of time for the collection of data, lack of apprentices and access not being given by certain centres to apprentices to be involved in the study. Finally, 484 apprentices were obtained for this study.

Instruments and Instrumentation

In this study, two instruments were used to obtain the data needed. First, a questionnaire that aimed to determine work values that the apprentices should have according to degree of importance was drawn up. It contained a list of proposed work values that had been determined through literature and the highlights of previous studies. From this, a total of 36 work values were listed

to determine the extent of their importance by coaches and instructors. Twenty-six of these were based on the work values listed in the Armed Services Vocational Battery Attitude (ASVAB) Career Exploration Program, while 10 of the work values were obtained from other literature. The respondents, made up of representatives of companies and training institutions involved in the NDTs, were asked to arrange the values identified according to the level of importance they attached to those values ranging from very important, important and not so important. It should be noted that these respondents were excluded from the actual research. Based on the feedback from the coaches and instructors and expert panel recommendations, seven of the work values were merged or absorbed into the other work values. This included values such as power and authority, security, validation and community. A total of 29 work values were shortlisted. These work values were then used to build a second instrument.

The second instrument was a questionnaire consisting of Likert-scale items. The items needed to measure each of the 29 work values were determined. The items were developed by the researchers and reviewed by a panel of experts in the field of work values to ensure the validity of its contents. Then, a pilot test was conducted on 69 respondents at a training institute to ensure the reliability of the items. Analysis based on feedback showed that Cronbach coefficients for the constructs studied were between .54 and .85. Using feedback obtained from the pilot study, several

items were removed to reduce the number of statements that apprentices needed to respond to as well as to improve reliability of the instrument. In addition, two work values were merged into one. The overall construct of work values used in the actual study was 26.

Parents' jobs were classified according to simple standard job categories, namely, those who do not work, labourers, skilled workers, professionals and retirees as no relationship of apprentice work values with specific job classification was sought in this research. Retirees were included as a category as their condition of not being in employment anymore could be seen as a particular work condition exerting an influence on the work values of their children (Whitbeck, Simons, Conger, Wickrama, Ackley, & Elder Jr., 1997).

Once the validity and reliability of the measurement of the instruments in the workplace among apprentices were established, the apprentices were asked to respond to the questionnaire that contained items on their work values. The actual reliability coefficient for the items show that all the work value constructs recorded coefficients between .53 and .82, except for two values. Since the two values recorded low-reliability coefficients, they were removed from the calculation, and finally only 26 work values were used in this study.

Data Collection Procedure

Researchers personally went to the training centres that were randomly selected. The apprentices were asked to gather in a room

or hall, and questionnaires were distributed and administered by the researchers. The average time taken to complete the questionnaires was about 40 minutes. Researchers collected the questionnaires once they had been completed.

Analysis of Data

Analysis of data by descriptive statistics and inferential statistics was used to formulate quantitative data that had been gathered. Descriptive statistics is a method used to describe data that is observed for meaningful results. It uses indications such as percentage, mean and standard deviation. Inferential statistics analysis such as ANOVA was used to determine whether there were any significant differences in work values of apprentices based on their parent's job, and Post Hoc was used to determine whether there were any significant differences in types of their father or mother's job on the work values.

RESULTS

Overall, out of the 484 apprentices involved in the study, 31 (6%) had fathers who did not work, 239 (50%) worked as labourers, 50 (10%) as skilled workers, 57 (12%) as professionals and 68 (14%) were retirees, while 39 (8%) did not report their father's job.

Based on a comparison of work value mean according to father's job, only three different work value means were found to be significantly different, namely, financial gain, searching for meaning and influencing others (Table 2).

Detailed results show that apprentices whose fathers were skilled workers placed greater emphasis on financial gain ($M = 3.45$, $SD = 0.49$) compared to apprentices whose fathers did not work ($M = 2.98$, $SD = 0.58$) and apprentices whose fathers worked as labourers ($M = 3.16$, $SD = 0.60$).

In the case of searching for meaning, apprentices whose fathers worked as skilled workers ($M = 3.60$, $SD = 0.47$) and apprentices whose fathers were retirees ($M = 3.59$, $SD = 0.43$) found this work value more important compared to apprentices whose fathers did not work ($M = 3.27$, $SD = 0.50$). Apprentices whose fathers were retirees felt that searching for meaning is more important compared to apprentices whose fathers did not work and those whose fathers worked as labourers ($M = 3.39$, $SD = 0.54$). For the work value influencing others, the

analysis shows that there was a significant mean difference, but the difference was relatively minor.

In relation to their mother's job, 333 (69%) apprentices had mothers who did not work, 48 (10%) worked as labourers, 21 (4%) as skilled workers, 41 (9%) as professionals and 7 (1%) were retirees. However, 34 (7%) apprentices did not report their mother's occupation.

A comparison of apprentices' work values based on their mothers' job showed nine different work values as being significant, namely working with other people, working mastery, change and variety, work precision, supervision, excitement, challenge, achievement and lifelong learning (Table 3).

The details show that apprentices whose mothers did not work ($M = 3.38$, SD

TABLE 2
Mean difference in Job Value Between Apprentice According to Father's Job

Dimension	Father Job	Min	Standard Deviation	F	Degree of Freedom	Significant
Financial gain	Did not work	2.98	0.58	4.273	4,435	.002
	Labourer	3.16	0.60			
	Skilled worker	3.45	0.49			
	Professional	3.25	0.58			
	Retiree	3.31	0.60			
Searching for meaning	Did not work	3.27	0.50	4.043	4,429	.003
	Labourer	3.39	0.54			
	Skilled worker	3.60	0.47			
	Professional	3.46	0.50			
	Retiree	3.59	0.43			
Influencing others	Did not work	2.77	0.48	2.438	4,436	.046
	Labourer	2.88	0.62			
	Skilled worker	3.06	0.56			
	Professional	2.99	0.62			
	Retiree	3.06	0.55			

TABLE 3
Mean Difference Job Value Between Apprentices According to Mother's Job

Dimension	Mother's Job	Min	Standard Deviation	<i>F</i>	Degree of Freedom	Significant
Working with others	Did not work	3.38	0.49	3.912	4, 442	.004
	Labourer	3.08	0.51			
	Skilled worker	3.28	0.54			
	Professional	3.32	0.57			
	Retiree	3.29	0.44			
Working mastery	Did not work	3.44	0.44	3.062	4, 442	.017
	Labourer	3.23	0.44			
	Skilled worker	3.49	0.41			
	Professional	3.49	0.44			
	Retiree	3.59	0.36			
Change and variety	Did not work	3.10	0.55	3.776	4, 443	.005
	Labourer	2.80	0.55			
	Skilled worker	3.18	0.52			
	Professional	3.05	0.50			
	Retiree	3.32	0.43			
Work precision	Did not work	3.18	0.54	3.753	4, 443	.005
	Labourer	2.98	0.48			
	Skilled worker	3.47	0.39			
	Professional	3.23	0.57			
	Retiree	3.46	0.40			
Supervision	Did not work	2.75	0.66	2.446	4, 442	.046
	Labourer	2.67	0.52			
	Skilled worker	3.15	0.70			
	Professional	2.79	0.55			
	Retiree	2.97	0.52			
Excitement	Did not work	3.02	0.56	2.878	4, 441	.023
	Labourer	2.95	0.51			
	Skilled worker	3.31	0.59			
	Professional	3.13	0.49			
	Retiree	3.43	0.69			
Challenge	Did not work	2.73	0.62	4.868	4, 441	.001
	Labourer	2.66	0.56			
	Skilled worker	3.25	0.55			
	Professional	2.56	0.54			
	Retiree	2.91	0.82			

TABLE 3 (continue)

Achievement	Did not work	3.31	0.52	2.890	4, 443	.022
	Labourer	3.06	0.60			
	Skilled worker	3.44	0.53			
	Professional	3.32	0.54			
	Retiree	3.36	0.66			
Lifelong learning	Did not work	3.20	0.53	2.660	4, 434	.032
	Labourer	2.98	0.48			
	Skilled worker	3.32	0.52			
	Professional	3.20	0.52			
	Retiree	3.46	0.40			

= 0.49) placed more emphasis on working with other people compared to apprentices whose mothers were labourers ($M = 3.08$, $SD = 0.51$). Apprentices whose mothers did not work ($M = 3.44$) and who worked as professionals ($M = 3.49$) felt job mastery was an important work value compared to apprentices whose mothers worked as labourers ($M = 3.23$). Apprentices whose mothers did not work ($M = 3.10$, $SD = 0.55$) also considered change and variety as an important work value compared to apprentices whose mothers worked as labourers ($M = 2.80$, $SD = 0.55$).

On the other hand, apprentices whose mothers were employed as skilled workers ($M = 3.47$, $SD = 0.39$) placed more emphasis on work precision compared to apprentices whose mothers were labourers ($M = 2.98$, $SD = 0.48$). Apprentices whose mothers were skilled workers ($M = 3.15$, $SD = 0.70$) also considered supervision important as a work value compared to those whose mothers did not work ($M = 2.75$, $SD = 0.66$) and who were employed as labourers ($M = 2.67$, $SD = 0.52$). Next, apprentices

whose mothers were skilled workers ($M = 3.25$, $SD = 0.55$) considered challenge as a more important work value compared to apprentices whose mothers did not work ($M = 2.73$, $SD = 0.62$), worked as labourers ($M = 2.66$, $SD = 0.56$) and were professionals ($M = 2.56$, $SD = 0.54$).

The final work value that records significant differences is achievement. Here the apprentices whose mothers were skilled workers ($M = 3.44$, $SD = 0.53$) and those who did not work ($M = 3.31$, $SD = 0.52$) felt achievement was important compared to apprentices whose mothers were labourers ($M = 3.06$, $SD = 0.60$). In terms of the work values of excitement and lifelong learning, the analysis shows a significant difference in mean. However, the difference is relatively minimal.

DISCUSSION AND IMPLICATIONS

Several work values showed significant differences in terms of the jobs of the apprentices' parents and the importance placed on these work values by apprentices. These findings support the literature on the

relationship between the characteristics and background of parents and the work values of adolescents in the context of sociological studies. The idea of intergenerational transmission of values accepts that transmission of values occurs from parents to children (Lorence & Mortimer, 1981; Mortimer & Lorence, 1979). Aside from this idea, the occupational linkage hypothesis (Vondracek & Profeli, 2005) also endorses these findings. The hypothesis assumes that parents' occupation and value of their jobs as well as their behaviour influence the work aspirations and achievement of teenagers towards those that reflect the parents' work values.

The findings also reflect social learning theory in that they emphasise the influence of modelling, that is, values modelling by parents in shaping children's values (Bandura, 1986; Farmer, 1985). Even though significant differences in values were found only in the context of certain values, these differences show that work values given importance by apprentices are related to the complex relationship between mothers, fathers and children as shown by Ryu and Mortimer's (1996) research findings. The findings also show that the type of values that children found to be important are related to their mother's job, where mothers are seen to exert a greater influence on the work values that apprentices consider important especially in terms of those values that are more intrinsic in nature whereas the father's job has more influence on values that are more extrinsic in nature.

Based on a review of the literature, there are three assumptions that can be made based on the work values that apprentices find important in this study when compared to their father or mother's jobs. First, the work values of apprentices may be similar or may follow the work values of either their mothers or fathers. Second, the work values of the mothers or fathers may be influenced by the type of job that they have, that is, whether they work or not, area of work, that is, as professionals, skilled workers, labourers or retirees. The third assumption is that the father or mother's jobs may affect the type of work values that apprentices consider important.

Based on these assumptions, the findings of this study, on the influence of the father's job towards work values of apprentices, show that there are significant differences in terms of the mean for two work values, that is, giving meaning and financial gain. According to Mannheim (1988), these two work values are more likely to be influenced by the father's job as his job is more likely to influence the child's intrinsic values such as 'pride in work', 'activity preference' and 'forward striving'. It is also possible to conclude from this study that giving meaning is among the two values that are more likely to be influenced by the father's job because it is a work value of the father's that may be easily understood and demonstrated through the father's actions and thoughts in the context of his work compared to other values such as moral satisfaction and friendship.

The findings also suggest that other work values such as job satisfaction and friendship may be more abstract in the way that they are demonstrated by the father. Hence, the importance of these work values among the apprentices is less likely to be noticeably influenced by the father's occupation. This could explain why no significant differences were found between father's occupation and the work values of apprentices for these two values. However, in the case of giving meaning, the findings suggest that this work value may be easily expressed by fathers from time to time in the context of discussing their work experiences and thus, is more likely to show a clear relation to the work values of apprentices. As an example, the apprentice's father may say that his work gives satisfaction, builds his character, garners interest and so on. At the same time, there is also the possibility that giving meaning may be a work value that is more easily understood and is identifiable in relation to apprentices when answering the questionnaire. As a result, the differences between the father's occupation and making meaning may be more apparent compared to other work values investigated. This may also be one reason why apprentices consider this work value as most important to them.

Another reason why the father's job may show significant differences with the work value giving meaning could be attributed to the notion that having a job or having worked or been employed before produces deep feelings among apprentices towards work or working as something that has value to them. It makes work valuable to

them. For example, having a job or having worked makes the apprentice's father as someone who has played a part in the family or in society. This influences the perceptions of the apprentices. The research findings of this study support this idea. They show higher means for those fathers who work as skilled workers or labourers and those who have worked before such as retirees. This finding can also be related to the idea of intergenerational transmission of values whereby the work experiences of parents have implications towards the work values of children. In this context, the idea of work and working among fathers or mothers may have certain values that emphasise work as something an individual should value as it gives meaning to the lives of either or both their parents. In addition, this perspective on transmission of values may play a role in influencing the work values of fathers, and hence, the apprentices themselves. This is shown in the findings of this study whereby the mean for apprentices whose fathers worked as skilled workers and retirees ($M = 3.45$; $M = 3.59$) differ significantly from apprentices whose fathers did not work ($M = 3.27$).

Another work value identified as having significant differences with the father's job based on the mean is financial gain ($f(4,435) = 4.273$, $p = .002$). This finding can be explained in terms of the fathers' influence towards the work values of children as evidenced and supported by the idea of intergenerational transmission of values. Despite the idea that financial gain is more extrinsic in nature, the value

still has intrinsic elements in terms of upward striving, that is, self improvement. This explanation supports Mannheim's (1988) findings, which concluded that father's occupation can influence intrinsic elements in the work values of their children. Specifically, the findings of this research show that there is a significant difference between apprentices whose fathers were skilled workers ($M = 3.45$) and apprentices whose fathers did not work or who worked as labourers ($M = 2.98$; $M = 3.16$). These findings also support the idea underpinning Mannheim's (1988) study that the father's occupation, specifically the values found within the father's job, could influence their children's work values. In the context of this study, the importance of financial gain as a work value among apprentices assumes that skilled workers look further and have hopes of gaining financial profits in terms of remuneration and promotion or producing work that is better or innovative. This may influence apprentices whose fathers were skilled workers to view financial gain as an important work value compared to apprentices whose fathers did not work or only worked as labourers. In the context of fathers who worked as labourers, 'labourer' may be understood as a job that allowed for no financial gain or profit, such as promotion.

In terms of the relationship between the mother's job and the work values of apprentices, the findings show there are significant differences in seven work values, that is, working with other people ($F(4,442) = 3.912, P = .004$), working mastery, change

and variety, work precision, supervision, challenge, and achievement. In the context of Mannheim's (1988) study, the work attitudes of mothers are found not to have much influence on the work values of children. According to Mannheim (1988), "maternal job attitudes were found to have little impact on the reduction of value dissimilarities". However, the findings of this study are interesting as they suggest the opposite. Work values of the apprentices were found to be influenced by the work values that their mothers found important in their jobs. This particular finding may also be connected to the close relationship between mothers and children compared to those with fathers in the context of Eastern cultures, specifically in Malaysia, where mothers continue to play a major role as educators despite having jobs and working outside the home.

Specifically, in terms of the work value working with others, the findings show that the mother's type of job results in significant differences in its importance among the apprentices. Apprentices whose mothers worked as labourers did not find this work value important compared to those whose mothers did not have a job ($M = 3.08$ and $M = 3.38$). This may be related to the maternal instincts of mothers, which tend to vary according to socioeconomic status, job and scope of job. In Mannheim and Seger's (1993) study on the characteristics of mothers and their relationship to the work values of adolescents, they mention Hoffman (1977) and Yankelovich's (1979) studies as showing that women who worked,

especially those whose work was of a low status, were more prone to value those values that were extrinsic in nature or have high instrumental value compared to women whose jobs were of a higher status (Mannheim, 1993). In the present study, women who did not work seemed to appreciate working with others. This seems to support Mannheim's conclusions. There is a possibility that the work values of mothers who did not work were more apt to be located between the work values of those of high and low status jobs. In the context of traditional Asian societies as is generally understood, mothers who do not work may have a higher status than those who do. For example, the idea of mothers as the main educators in the lives of their children may have some effect on these particular findings. Based on this idea and the findings of previous research (Hoffman, 1977; Yankelovich, 1979), apprentices whose mothers did not work may have been taught to appreciate and value working with others ($M = 3.38$) compared to apprentices whose mothers worked as labourers. The latter may be more likely to not place importance on this work value ($M = 3.08$) because their job may be more individual in nature.

The same thing can be concluded in terms of the importance of the work value change and variety, where significant differences were found between apprentices whose mothers worked as labourers and those whose mothers did not work ($M = 2.80$; $M = 3.10$). 'Change and variety' is found to be perceived slightly differently by apprentices compared to working with

other people in terms of its importance as a work value. The apprentices seemed to consider change and variety as having intrinsic value but did not perceive it as having altruistic characteristics such as in the case of working with others. Apprentices seemed to perceive change and variety as a need for personal satisfaction rather than one of inner satisfaction. In this respect, the connection between mothers who did not work and the importance of this work value among their children may be related to the mothers having needed to get out of their daily routine in the house and the desire for change and variety in their day-to-day lives. This may have motivated the mothers who did not work to value change and variety more, and hence, made it important as a work value in the minds of their children as well. This is where 'maternal instincts' differ according to the scope of the parent's jobs, although in comparison, mothers who worked as labourers may tend to emphasise values other than change and variety. This may have led apprentices whose mothers were labourers to rate other work values more highly.

Therefore, in order to develop human capital specifically apprentices for industry in terms of their commitment towards work, coaches, trainers and employers have to focus on understanding and appreciating the work values of their apprentices while at the same time getting the apprentices to understand the kind of work values desired by the organisation. Coaches, trainers and potential employers have to give more consideration to research findings that

show their apprentices, being young, are still greatly influenced by their background values, specifically their mother and father's values and work values. They have to provide support for programmes that allow apprentices to adapt to the work values of their organisation.

Generally, research on young workers has shown that there is a need to provide an appropriate work environment. This environment should be one that emphasises the work values of the employer yet also contributes towards increased job satisfaction among their workers. This environment should be one that promotes a strong working relationship between the supervisor and the apprentice. The focus of this relationship should be job satisfaction through shared work values (Frone, 2000). In addition, communication in the work place has to be stressed (Tresize-Brown, 2004).

Research into young workers and apprentices has also shown that opportunities should be given to young workers to make mistakes and learn from them (Tresize-Brown, 2004). Reducing the gap between the work values of apprentices and their employers or coaches is also important. In addition, enculturing apprentices to the work values of the organisation through early exposure to work values of the organisation are important. Proactive steps should be taken in the management of young workers.

In the case of apprentices, there is a need to identify them as youths. Organisations need to recognise that youths are more likely

to be influenced by certain background factors such as their parents because they may have great influence on the youths' value systems especially their work values. The findings of this study show that parent's job and, indirectly, their values and value systems do affect the work values of their children. Coaches, trainers and employers should not ignore this. They should take steps to draw up specific programmes such as mentor-mentee programmes that allow greater interaction between trainers, coaches and employers either at the training centres or work place. This would help the transmission of values that are required by the organisations where these apprentices will eventually be placed. It would also allow the organisations to understand and appreciate the work values of the apprentices. This would give greater validation to apprentices as a valued member of the organisation, thus increasing job satisfaction among apprentices and increased commitment towards their work. In addition, these programmes should involve simulation and immersion techniques that allow apprentices the opportunity to experience the work values of their employers or future employers. The programmes should also have a communication system in place that caters for young workers and fosters close dialogue between apprentices and trainers, coaches or employers. This would allow those in charge to intervene and remedy any situation where conflict or disagreement in values may occur.

CONCLUSION

The study raises an important question for employers in terms of what needs to be done to prepare young workers to enter their organisations. One of the questions is about the work values that these workers bring with them that can affect their satisfaction and further their commitment to work. This study suggests that some information about the work values may be obtained by considering their background, specifically, their parents' job. The study does suggest that to a limited extent parents' job may influence young workers' work values. Relating this to the wider literature, employers should perhaps give more recognition to the work values of apprentices especially if they are young people entering the work force for the first time. Giving more consideration to workers' background such as their work values, and understanding what influence parents' jobs have could help employers determine what kind of environment may be more suitable for young workers. In the long run this approach could help to keep young workers more committed to their work and the organisation they work for while helping to reduce the possibility of high turnover of staff.

REFERENCES

- Abramovitch, R., & Johson, L. C. (1992). Children's perception of parental work. *Canadian Journal of Behavioural Science*, 24(3), 319-332. doi: 10.1037/h0078721
- Bandura, A. (1986). *Social foundations of thought and action: A social cognitive theory*. Englewoods Cliffs: Prentice Hall.
- Barling, J., Dupree, K. F., & Hepburn, C. G. (1998). Effects of parent's job insecurity on children's work beliefs and attitudes. *Journal of Applied Psychology*, 83(1), 112-118. doi: 10.1037/0021-9010.83.1.112
- Barling, J., Kelloway, F. K., & Bremermann, E. H. (1991). Pre-employment predictors of union attitudes: The role of family socialization and work beliefs. *Journal of Applied Psychology*, 76, 725-731.
- Berti, A. F., & Bombi, A. S. (1988). *The child's construction of economics*. Cambridge: Cambridge University Press.
- Bryant, B. K., Zvonkovic, A. M., & Reynolds, P. (2006). Parenting in relation to child and adolescent vocational development. *Journal of Vocational Behavior*, 69(1), 149-175. doi:10.1016/j.jvb.2006.02.004
- Chen, J., Chu, K., & Wu, W. (2000). Tourism students' perceptions of work values: A case of Taiwanese Universities. *International Journal of Contemporary Hospitality Management*, 12(6), 360-365. doi:10.1108/09596110010343549
- Dekker, I., Greenberg, L., & Barling, J. (1998). Predicting union attitudes in student part-time workers. *Canadian Journal of Behavioural Science*, 30, 49-55. Retrieved from <http://web.business.queensu.ca/faculty/jbarling/Papers/Predicting%20Union%20attitudes%20in%20student.pdf>
- Doepke, M., Zilibotti, F. (2005). Social class and the spirit of capitalism. *Journal of the European Economic Association*, 3(2/3), 516-524. Retrieved from <http://www.jstor.org/stable/40004994>
- Dohmen, T., Falk, A., Huffman, D., & Sunde, U. (2012). The intergenerational transmission of risk and trust attitudes. *Review of Economic Studies*, 79(2), 645-677. Retrieved from <http://www.cens.uni-bonn.de/team/board/armin-falk/the-intergenerational-transmission-of-risk-and->

- trust-attitudes-review-of-economic-studies-2012-792-645-677-with-thomas-dohmen-david-huffman-and-uwe-sunde..pdf
- Fabian Jintae Froese, & Shufeng Xiao. (2012). Work values, job satisfaction and organizational commitment in China, *The International Journal of Human Resource Management*, 23(10), 2144-2162. doi:10.1080/09585192.2011.610342
- Fraenkel, J. R., & Wallen, N. E. (1993). *How to design and evaluate research in education* (2nd ed.). New York: McGraw-Hill Inc.
- Fruend, A. (2005). Commitment and job satisfaction as predictors of turnover intentions among welfare workers. *Administration in Social Work*, 19(2), 5–22. doi:10.1300/J147v29n02_02
- Frone, M. R. (2000). Interpersonal conflict at work and psychological outcomes: Testing a model among young workers. *Journal of Occupational Health Psychology*, 5(2), 246-255. Retrieved from PsycNET.
- Hoffman, L. W. (1977). Changes in family roles, socialization, and sex differences. *American Psychologist*, 32(8), 644-657. doi: 10.1037/0003-066X.32.8.644
- Jurkiewicz, C. I. (2000). Generation X and the public employee. *Public Personnel Management*, 29(1), 55-74. Retrieved from PsycNET.
- Kalleberg, A. L. (1977). Work values and job rewards: A theory of job satisfaction. *American Sociological Review*, 42(1), 124-143. Retrieved from <http://www.jstor.org/stable/2117735>
- Kanwar, Y. P. S., Singh, A. K., & Kodwani, A. D. (2009). A study of job satisfaction, organizational commitment and turnover intent among the IT and ITES. *Vision: The Journal of Business Perspective*, 13(2), 1-12. doi: 10.1177/097226291201600103
- Kelloway, F. K., & Watts, I. (1994). Pre-employment predictors of union attitudes: Replication and extension. *Journal of Applied Psychology*, 79, 632-634.
- Kelloway, F. K., & Newton, T. (1996). Pre-employment predictors of union attitudes: The roles of parental work and union attitudes. *Canadian Journal of Behavioural Science*, 28(2), 113-120. doi: 10.1037/0008-400X.28.2.113
- Lorence, J., & Mortimer, J. T. (1981). Work experience and work involvement. *Sociology of Work and Occupations*, 8, 297-326. doi: 10.1177/073088848100800302
- Loughlin, C., & Barling, J. (2001). Young workers' work values, attitudes, and behaviours. *Journal of Occupational and Organizational Psychology*, 74(4), 543-558. doi: 10.1348/096317901167514
- Maccoby, M. (1995). *Why work? Motivating the new workforce*. Alexandria: Miles River Press.
- Mannheim, B. (1988). Social background, schooling and parental job attitudes as related to adolescents' work values. *Youth & Society*, 19, 269-293. doi: 10.1177/0044118X88019003003
- Mannheim, B., & Seger, T. (1993). Mother's occupational characteristics, family position, and sex role orientation as related to adolescents' work values. *Youth & Society*, 24(3), 276-298. doi: 10.1177/0044118X93024003002
- McCrindle, M. (2003). Understanding generation Y. *Principal Matters*, 55, 28-31. Retrieved from <http://ec-web.elthamcollege.vic.edu.au/principal/pdf/Understanding%20Generation%20Y.pdf>
- Mitra, A., Jenkins, D., & Gupta, N. (1992). A meta-analytic review of the relationship between absence and turnover. *Journal of Applied Psychology*, 77, 897-889. Retrieved from PsycNET.

- Mortimer, J. T., & Lorence, J. (1979). Work experience and occupational value socialization: A longitudinal study. *American Journal of Sociology, 84*, 1361-1385.
- Ngunia, S., Slegers, P., & Denessen, E. (2006). Transformational and transactional leadership effects on teachers' job satisfaction, organizational commitment, and organizational citizenship behavior in primary schools: The Tanzanian case. *School Effectiveness and School Improvement, 17*(2), 145-177. doi:10.1080/09243450600565746
- Petty, G. C., Brewer, E. W., & Brown, B. (2005). Job satisfaction among employees of a youth development organization. *Child and Youth Care Forum, 34*(1), 57-73. doi: 10.1007/s10566-004-0882-8
- Porter, L. W. S., Richard, M. M., Richard, T., & Boulian, P. V. (1974). Organizational commitment, job satisfaction, and turnover among psychiatric technicians. *Journal of Applied Psychology, 59*(5), 603-609. Retrieved from PsycNET.
- Ryu, S., & Mortimer, J. T. (1996). The operational linkage hypothesis applied to occupational value formation in adolescence. In J. T. Mortimer, & M.D. Finch (Eds.). *Adolescence, work and family: An intergenerational development analysis: understanding families*. Thousand Oak, CA: Sage.
- Tresize-Brown, M. (2004). *Employing young workers: How well are we managing them?* Fitzroy: Brotherhood of St. Laurence.
- Vondracek, F. W., & Profeli, E.J. (2005). The world of work and careers. In G. R. Adams, & Berzonsky, M. D. (2005). *Blackwell handbook of adolescence*. Oxford: Blackwell Publishing.
- Wanous, J. P., & Lawler, E. E. (1972). Measurement and meaning of job satisfaction. *Journal of Applied Psychology, 56*(2), 95-105. Retrieved from PsycNET.
- Whitbeck, L. B., Simons, R. L., Conger, R. D., Wickrama, K. A. S., Ackley, K. A., & Elder Jr. G. H. (1997). The effects of parents' working conditions and family economic hardship on parenting behaviors and children's self-efficacy. *Social Psychology Quarterly, 60*(4), 291-303. Retrieved from <http://www.jstor.org/stable/2787091>
- Yankelovich, D. (1979). Work values and the new breed. In C. Kerr, & J. M. Rosow (Eds.) *Work in America: The decade ahead*. New York: Von Nostrand Reinhold.
- Zemke, R., Raines, C., & Filipezak, B. (2000). *Generation at work: Managing the clash of veterans, boomers, xers, and nexters in your workplace*. Washington: American Management Association.



Promoting Receptive Vocabulary Growth among Undergraduates: Focused In-Class Reading with Writing Activity

Nor Ashikin, A. M.^{1*}, Johana, Y.¹ and Pandian, A.²

¹*Academy of Language Studies, Universiti Teknologi MARA (UiTM) Perak,
32610 Bandar Baru Seri Iskandar, Perak, Malaysia*

²*School of Languages, Literacies and Translation, Universiti Sains Malaysia,
11800 Penang, Malaysia*

ABSTRACT

This paper reports the results of a mixed-method study which was conducted to investigate whether Malay ESL learners who were, at the time the study was conducted, first-year Diploma in Computer Science students in a public university in Malaysia could improve their receptive vocabulary knowledge incidentally while reading silently in the classroom. A quasi experiment and a focus group interview were used to collect quantitative and qualitative data, respectively. The following were the two main research questions of the study: a) What is the effect of focused in-class reading with writing activity on the students' receptive vocabulary knowledge at the 2,000 word-family level? b) What are the students' perceptions of these activities in improving their vocabulary knowledge? The study concluded that a short period of focused in-class reading and writing activity conducted consistently can improve L2 learners' receptive vocabulary knowledge. Although both the experimental and control groups showed significant improvement in their receptive vocabulary knowledge at the 2000-word level, the vocabulary growth for the experimental group was higher than for the control group. In addition, the participants perceived focused in-class reading with writing activity as beneficial in improving their general vocabulary knowledge.

Keywords: Focused in-class reading, receptive vocabulary, vocabulary growth, word family

ARTICLE INFO

Article history:

Received: 8 December 2011

Accepted: 3 March 2014

E-mail address:

noras914@perak.uitm.edu.my (Nor Ashikin, A. M.),

* Corresponding author

INTRODUCTION

It has been proven through research in the field of second-language acquisition (SLA) that the success of learning a second language (L2) is highly correlated to the

learners' vocabulary knowledge (Waring & Nation, 2004). Krashen (1993), a proponent of the notion 'simply reading', believes that reading is the only way to improve vocabulary knowledge. However, recent research in vocabulary acquisition has come to the conclusion that reading alone is not as effective as originally believed in promoting incidental vocabulary learning. According to Schmitt (2008), incidental word learning from exposure to reading alone requires a large amount of textual exposure, results in learning a small number of new words and facilitates the development of partial rather than complete word knowledge. Thus, researchers such as Laufer (2003), Schmitt (2008), Peters, Hulstijn, Sercu and Lutjeharms, (2009) have taken the 'input plus' position, a term used in Peters *et al.* to describe reading (input) plus other productive activity such as writing, to increase learners' exposure to and involvement with unfamiliar words.

Reading for pleasure has been known to provide quantitatively and qualitatively rich context and resource for lifelong vocabulary development (Eckerth & Tavakoli, 2012) since extensive exposure to textual input is vital to achieve the breadth (Nation, 2006) and depth (Nation, 2001) of vocabulary knowledge. However, one of the biggest challenges faced by ESL teachers in Malaysia is to encourage Malaysian students to read in English. The fact that reading is still not the general favourite past time of Malaysians has been highlighted in many surveys on reading habits. Based on the survey conducted in

2010, Malaysians read between eight and 12 books per year (2013). Another survey conducted among undergraduates of a public university found that only 27% of the respondents read daily and 4% almost or never read outside class hours (Rahim, Shazila, & Shareena, 2007). In a related study, although university students were found to spend more time reading compared to the average Malaysian, 72% of the materials they read were directly related to their academic work (Karim & Hasan, 2007). These studies did not investigate their language preference, but it can be hypothesised that the students would most likely use their mother tongue when reading for pleasure as attested by Noor (2011). The respondents in her study stated that English was their language of choice when reading academically but when reading for pleasure, they preferred to read in their mother tongue. Annamalai and Muniandy (2013), who conducted a survey among Malaysian Polytechnic students, found that 83.2% of the respondents preferred to read in Bahasa Malaysia compared to other languages.

Therefore, it is not surprising that Malaysian undergraduates are found to be poor in receptive (Mokhtar, Rawian, & Yahaya *et al.*, 2010) and productive vocabulary knowledge (Jamian, Sidhu, & Muzafar, 2008; Mokhtar, Rawian, & Yahaya *et al.*, 2010). Thus, one of the most frequently-asked questions among ESL educators at tertiary level is: What can be done to ensure that undergraduates read in the target language to improve their receptive as well as productive vocabulary knowledge?

University undergraduates normally have a busy schedule and it is difficult for ESL teachers to persuade them to read English materials outside class hours. Therefore, this study was carried out to determine whether it is possible for ESL learners to improve their vocabulary knowledge by participating in focused in-class reading for a period of 30 minutes per session, with out-of-class writing activity three times per week. The activity was called ‘focused in-class reading’ because it was done in class during ESL lessons under close supervision of the class teacher. The materials that the students read were general in nature and not directly related to their academic work. The writing activity was conducted outside class hours as a follow-up to the in-class reading activity. This paper reports the results of the study that was conducted to investigate whether Malay ESL learners who are first-year Diploma in Computer Science students in a public university in Malaysia could improve their receptive vocabulary knowledge incidentally while reading silently in the classroom. A quasi experiment and a focus group interview were used to collect the quantitative and qualitative data respectively. The following were the two main research questions of the study:

- RQ1: What is the effect of focused in-class reading with writing activity on the students’ receptive vocabulary knowledge at the 2,000 word-family level?

- RQ2: What are the students’ perceptions of these activities in improving their vocabulary knowledge?

RECEPTIVE AND PRODUCTIVE VOCABULARY KNOWLEDGE

Vocabulary knowledge has been classified into two different categories: receptive and productive vocabulary. Nation (1990, p.5) has defined receptive or passive vocabulary as “the ability to recognize a word and recall its meaning when it is encountered.” According to Nation (1990), receptive or passive vocabulary are words which are initially encountered, learned, comprehended and accumulated in one’s memory accordingly via reading and listening. Receptive or passive vocabulary can also be defined as the way the meaning of a word is retrieved and understood by the learner when he or she is exposed to written or oral input (Nation, 2001). On the other hand, productive vocabulary, which is also known as active vocabulary, refers to the ability to retrieve the needed vocabulary from memory by using it at the appropriate time and in appropriate situations (Nation, 1990; Fan, 2000). Nation (2001) further explains that productive or active vocabulary is the process of retrieving (receptive/passive knowledge) and producing the appropriate written or spoken language form to get access to its meaning. It involves knowing how to pronounce the word, how to write and spell it and how to use it in correct grammatical patterns along with the words with which it is usually in collocation. This process will occur when one is engaged in writing or speaking.

As illustrated in Fig.1, Waring (2002) describes the development of vocabulary knowledge as moving from receptive knowledge on the left, along a continuum towards productive knowledge on the right. From this perspective, the receptive knowledge of a word is a requirement of productive knowledge. In addition, word knowledge is said to be incremental (Nagy & Scott, 2000), and learners' are found to increase their receptive vocabulary size incrementally and constantly over time (Gallego & Llancho, 2009).

Research conducted by Goulden, Nation and Read (1990), Nation and Waring (1997) estimate that the average receptive vocabulary size of a university-educated native English speaker is around 17,200 base words or word families. A 'word family' as defined by Nation (2001) consists of a headword, its inflected forms and its closely-related derived forms. Based on these estimates university-educated non-native English speakers should aim to learn about 17,000 word families. According to Nation (1990) advanced level ESL learners are generally expected to have acquired a minimum productive English vocabulary of 2000 to 3000 word families and a slightly larger receptive vocabulary of 3000 to 5000 word families. Read (2000) and Nation (1990) have also pointed out that ESL

learners pursuing tertiary level education should aim at acquiring the university word level with a vocabulary of about 5,000 to 10,000 word families. Adolphs and Schmitt (2004) have come out with a more recent estimate. In order to understand around 90% of written and 94% of spoken discourse, a learner needs to master 2000 word forms, while Nation (2006) estimates that for 98% coverage, 8000 to 9000 word families are required to understand a written text and 6000 to 7000 word families are needed for comprehension of spoken discourse. Based on all these estimates, it is felt that ESL learners at tertiary level should have mastered the 2000-word level upon entering their respective academic programmes. As undergraduates, they should aim to reach at least the university word level of the 5000-word family in order to participate effectively in academic discourse, as a vocabulary of below the university word level would hamper their learning process.

READING TO PROMOTE VOCABULARY LEARNING

There have been numerous investigations to support that reading is beneficial for indirect vocabulary learning (Jenkins, Stein, & Wyoski, 1984; Nagy, Anderson, & Herman, 1987) and that some vocabulary growth occurs through incidental learning

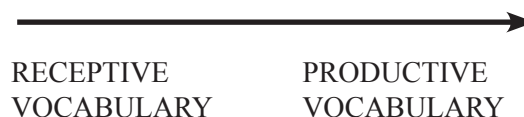

Fig.1: A continuum of receptive and productive vocabulary knowledge

(Horst, Cobb, & Meara, 1998; Pitts, White, & Krashen, 1989). Nagy et al. claim that the results of their study show beyond reasonable doubt that incidental vocabulary learning takes place during normal reading. Although these studies were conducted among L1 learners, Krashen (1989) has extended this claim to include secondlanguage learning as well. This claim has been supported empirically by Day, Omura and Hiramatsu (1991), whose study provides evidence that ESL learners can learn vocabulary of the target language through reading.

Krashen (1993), a proponent of the notion 'simply reading' to promote language competence believes that reading is the only way to improve vocabulary knowledge and claims that other methods of vocabulary learning are less effective. However, Schmitt (2008) in his study of L2 vocabulary acquisition has opined that incidental word learning from exposure to reading alone is inadequate in learning new words. This view is supported by Laufer (2003), who concludes that vocabulary learnt through productive word-focused tasks was retained longer than from reading alone. According to Peters et al. (2009) and Yamamoto (2011) learning vocabulary through reading, together with various types of productive word-enhancement tasks, is more effective than learning from reading alone because the vocabulary learnt would be retained longer. Eckerth and Tavakoli (2012) compared 'word exposure frequency' and 'elaboration of word processing' on the initial word learning and subsequent word retention of advanced learners of L2 English

and concluded that processing words again after reading (input-output cycles) is superior to reading-only tasks.

VOCABULARY LEVEL OF UNDERGRADUATES IN MALAYSIA

Many local researchers have conducted studies among Malaysian undergraduates to determine their level of vocabulary knowledge. One of the studies was conducted by Jamian et al. (2008) among 90 teacher trainees who were pursuing a Bachelor of Education in Teaching English as a Second Language (TESL) degree at a public university in Malaysia. It was found that the students' mastery of vocabulary knowledge at the 2000-word level was 80% on average while their mastery at the 3000-word level was 66%. Their mastery at the 5000- and 10000-word levels were 44% and 33% respectively. The study revealed that they had failed to achieve even 50% at the university word level (5000-word families) despite being highly engaged with listening, reading, speaking and writing activities in English. It can be concluded from this study that active involvement in the language does not necessarily contribute to students' mastery of vocabulary knowledge.

Another related study was conducted by Mokhtar et al. (2010) among 360 undergraduates from a Malaysian public university. It was found that the majority of the subjects failed to achieve the passing level of the Passive and Controlled Active Vocabulary Test, which means that they had poor passive and active vocabulary knowledge. The findings reveal that the

average size of the students' passive vocabulary was 1528 word families for semester one, 1653 word families for semester two and 1968 word families for semester three. These averages show a growth rate of 440 word families per year. On the other hand, the average size of the students' controlled active vocabulary were shown to be 1691, 2116 and 2154 for semester one, two and three respectively with a growth rate of 459 word families per year. The results show that without intervention it is quite impossible for these undergraduates to achieve the vocabulary of at least 5000 word families as expected of tertiary-level learners.

METHODOLOGY

The Study

The study was a mixed-method utilising a quasi experiment and a focus group interview. It was carried out for a duration of 12 weeks during the subjects' normal ESL class hours. The subjects attended three two-hour classes per week during a 14-week semester. The first and the last weeks of the semester were used for conducting the pre- and post-VLT (Vocabulary Level Test), respectively. The main objective of this study was to determine whether reading for pleasure can increase ESL learners' general vocabulary size. Since recent literature in vocabulary development has proposed that reading plus other productive word-processing activity such as writing is better than reading alone in promoting vocabulary acquisition, this study incorporated writing in its experiment.

The Participants

The participants of this case study were first-year Diploma in Computer Science students from the Perak state campus of University Teknologi MARA. Forty-four students from two intact groups who were enrolled in a proficiency level English course were assigned as participants for the experimental and the control groups. Each group consisted of 22 participants. The participants were homogeneous in the sense that all of them were between 18 and 20 years old at the time of data collection and all of them were *Sijil Pelajaran Malaysia* (SPM) certificate holders. In addition, they shared the same mother tongue, which was Malay, and all of them had been exposed to English for at least 11 years in primary and secondary school before entering university. General background information on the participants is presented in Table 1.

The Instruments

The instrument used to collect quantitative data in the study was Vocabulary Level Test (VLT) Version 1 and 2 while qualitative data was collected using a mini focus group interview. The validity evidence and the equivalence study for both versions of the VLT can be found in Schmitt, Schmitt and Clapham (2001). The test uses word-definition matching format which requires test-takers to match the words to the definitions. It measures knowledge of words at five levels: 2000, 3000, 5000, 10000 and academic English words. The cut-off point for acquiring each level was 24 over 30 (80%) as suggested by Schmitt et al. In this

TABLE 1
General Background Information on the Participants

Experimental group			Control group		
Female	16		Female	16	
Male	6		Male	6	
Total	22		Total	22	
SPM Grade For English	Frequency	%	SPM Grade For English	Frequency	%
B+	4	18.2	B+	8	36.4
B	3	13.5	B	1	4.5
B-	1	4.5	B-	0	0
C+	6	27.3	C+	5	22.7
C	4	18.2	C	5	22.7
D	4	18.2	D	3	13.5
Total	22	100	Total	22	100

study, the students only sat a 2000-word-level test. At each level, 30 definitions needed to be matched to 30 out of 60 words. Table 2 shows an example of the test items.

TABLE 2
Sample of VLT items

1 business	
2 clock	___ part of a house
3 horse	___ animal with four legs
4 pencil	___ something used for writing
5 shoe	
6 wall	

Research Procedure

Determining the equivalence of experimental and control groups

At the beginning of the study period all the participants sat Version 2 of the VLT, which was considered the pre-test. The scores were analysed using SPSS for Windows Version 16.0 to determine whether the experimental and the control groups were selected from the population with equal variances and means. Table 3 shows the

Independent Sample Test results. The 'Independent Sample Test' (Levene's Test for Equality of Variances) table reported a p value of 0.258, which was more than the predetermined $\alpha = 0.5$. This means that the null hypothesis, ($H_0: \sigma_1^2 = \sigma_2^2$), failed to be rejected. In other words, there was no significant difference in the variances of test scores between the experimental and the control groups. Hence, the 'Independent Samples Test' for equality of means (equal variances assumed) was reported. The 'Independent Samples Test' (t-test for the equality of means) table showed that the p (2-tailed) value was 0.865, which is larger than the predetermined alpha value ($\alpha/2 = 0.025$). Thus, the null hypothesis, ($H_0: \mu_1 = \mu_2$), failed to be rejected. This means that there was no significant difference between the means of the experimental and the control group at the 2000-word level. This conclusion was made at a confidence level of 95%.

TABLE 3
Independent Samples Test for 2000-word Level

		Levene's Test for Equality of Variances		t-test for Equality of Means						
		F	Sig.	t	df	Sig. (2-tailed)	Mean Difference	Std. Error Difference	95% Confidence Interval of the Difference	
								Lower	Upper	
PRE2K	Equal variances assumed	1.312	.258	-.171	42	.865	-.273	1.594	-3.490	2.944
	Equal variances not assumed			-.171	41.264	.865	-.273	1.594	-3.491	2.946

The treatment

The main objective of this study was to determine whether reading for pleasure on general topics outside their field of studies can increase the size of ESL learners' general vocabulary. In order to ensure that the subjects actually carried out reading activities in the target language, the class teacher had provided the experimental group learners with a collection of reading materials in L2. These reading materials were made available to the experimental group learners throughout the study period.

Focused-reading

Table 4 details the types of reading material made available to the subjects. The subjects would choose the reading material they preferred and keep it for a week, or if they finished reading the material earlier, they could choose a different book even before the week was up. The class teacher would keep a record of their borrowing and returning transactions. The first 30 minutes of class time was allocated for reading these L2 materials. Since 30 minutes was

too short for the subjects to finish reading some of the books, the reading activity was carried out after class at the students' leisure. The subjects were encouraged to use the dictionary and were taught to record the new words that they encountered in the reading activities. At least three new words would be highlighted by a selected subject in every class. This means that at the end of the study period, each subject would have been exposed to at least nine new words per week and a total of 108 new words throughout the study period. Table 5 shows the activities carried out by the experimental group.

TABLE 4
Reading Materials for the Study

Types	Quantity
Old Edition Reader's Digest	30 copies
Story Books (Classics)	10 copies
Story Books (Contemporary)	10 Copies

Writing task

The subjects were asked to write a summary of between 200 and 250 words of the books or articles that they had read during the

focused in-class reading activity. The writing task was an out-of-class assignment and due to time constraint, the class teacher did not mark the summaries. Only the number of summaries submitted by the subjects at the end of every week was recorded.

Data collection

The quantitative data for this study come from a pre- and post-VLT which was conducted on the first and the last week of the semester, respectively. The qualitative data were collected using a mini focus group interview conducted at the end of the study period. Four students of mixed-ability were chosen for this interview. The 30-minute interview was semi-structured and was carried out by the researcher herself. The subjects were allowed to use Malay to answer the questions but during the interview all of them tried to answer in English. The objective of the interview was to investigate the students' perception of the focused in-class reading and writing activities. The interview was tape-recorded and the data were then analysed. Four major questions were posed to the subjects during the interview. The four major questions were: 1) Do you think focused in-class reading and writing activities are beneficial

in improving your general vocabulary knowledge? 2) Do you have any problems in completing the writing assignments? 3) Do you think you will be able to use the new words you learnt during the focused in-class reading? 4) Are you more confident in dealing with unknown words now compared to before the experiment? The design of the study is summarised diagrammatically in Table 6.

RESULTS

At the end of the study period, the number of books and articles read as well as the number of summaries written by each subject were calculated. The data are shown in Table 7. The total number of books or articles read throughout the study period was 262 while the number of summaries written was only 232. The discrepancy may be due to the following reason. Focused in-class reading was an in-class activity under close supervision by the class teacher, thus the subjects were more motivated to participate in this activity compared to summary writing, which was done as an out-of-class assignment. Since the summaries submitted by the subjects were not marked by the class teacher, some subjects did not write or submit them. The highest number of books

TABLE 5
Reading and Writing Activities

In-Class Activities	Out-of-class Activities
1. Reading (30 minutes)	1. Write a 250-word essay based on what they read to be submitted in the following week during ESL class.
2. Discuss new words as part of <i>Reading Comprehension</i> lesson (15 minutes).	2. Choose 3 new words that they encountered; to be discussed in class.

TABLE 8
VLT Scores for Pre- and Post-Tests

	CONTROL		EXPERIMENTAL	
	PRE 2K	POS 2K	PRE 2K	POS 2K
Total Score	481	554	475	601
Mean	21.86	25.18	21.56	27.32
% of known words	72.96	83.93	71.96	91.06
% of unknown words	27.13	16.06	28.13	8.93
Word Known	1458	1679	1439	1821
Word Growth	221		382	

TABLE 9
Results for Paired Sample Test at 2000-word Level

	Paired Differences	t	df	Sig. (2-tailed)					
					Mean	Std. Deviation	Std. Error Mean	95% Confidence Interval of the Difference	
								Lower	Upper
Pair 1	PRE2K_E - POS2K_E	-5.72727	4.63097	.98733	-7.78053	-3.67402	-5.801	21	.000
Pair 2	PRE2K_C - POS2K_C	-3.31818	4.22449	.90066	-5.19122	-1.44515	-3.684	21	.001

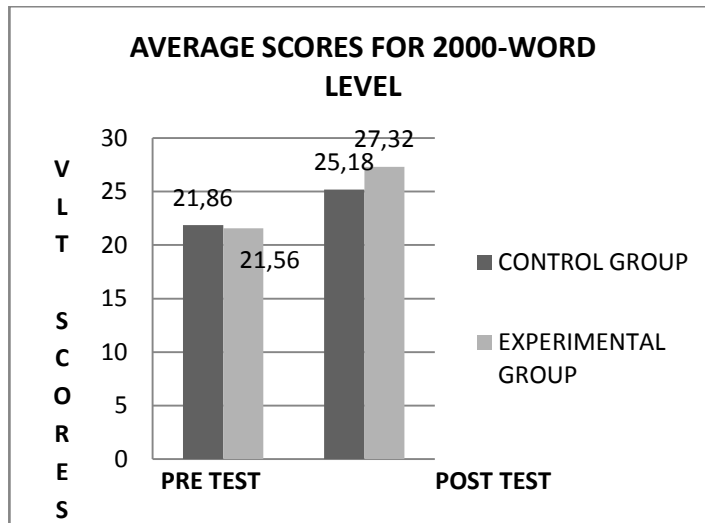

Fig.2: Means for 2000-word level

seen that the experimental and the control groups show *p* values of 0.00 and 0.001 respectively. Since both values were less than the predetermined alpha value ($\alpha / 2 = 0.025$), the null hypotheses for both the experimental and the control groups were rejected. This means that there exists adequate evidence to show that there are significant differences between the means of pre- and post-tests for both the experimental and the control groups at the 2000-word level. Both the experimental and the control groups performed better in the post-test compared to the pre-test.

Focus Group Interview Result

Based on the interview data, it can be concluded that the subjects perceived the experiment positively. Although they admitted that they lacked confidence in using the new words they had learnt from the reading activity, they were motivated to use them in their writing. Table 10 to 13 show excerpts of the interview dealing with the four major questions. Only responses

that are related to the major questions are included in the excerpts. The students' perception is summarised as follows:

1. The subjects believed that the focused in-class reading and writing activity that they had undertaken had been beneficial in improving their receptive vocabulary knowledge.
2. They felt that the writing activity provided them with the opportunity to use the new words they had learnt during the focused in-class reading.
3. They felt that summary writing should be carried out as an in-class activity.

DISCUSSION

Research Question 1

To address the first research question, the scores for both the experimental and the control groups were compared. The histogram in Fig.2 clearly shows the difference between the means for the experimental and the control groups. The post-test results show that the experimental

TABLE 10
Excerpt from Focus Group Interview: Question 1

<p>QUESTION 1: Do you think focused-reading and writing activities are beneficial in improving your general vocabulary knowledge?</p> <p><i>Subject 1 : "I think it is very useful. Writing activity is good because I can practise to use new words that I found in the story book...I don't feel stress because teacher don't mark the summary."</i></p> <p><i>Subject 3 : "I agree ...it useful. I learn many new words. I like to read after class but no time... sometimes not finish reading, just write Summary."</i></p> <p><i>Subject 2 : "My English is not good. I know reading can improve my vocab...so I think the activity is good to learn new word and practise writing."</i></p> <p><i>Subject 4 : "I like the activity because I like reading. I think thirty minutes is too short...not enough time to discuss meaning of new word."</i></p>

TABLE 11
Excerpt from Focus Group Interview: Question 2

<p>QUESTION 2: Do you have any problems in completing the writing assignments?</p> <p><i>Subject 2 : "I also learn new words but sometime I cannot finish writing assignment ...I think if writing in class better."</i></p> <p><i>Subject 1 : "True, I agree...teacher should explain new words until we understand. Sometimes I cannot finish writing summary, maybe should write in class. Got many assignment".</i></p> <p><i>Subject 3 : "I think it useful...but too short... time not enough to finish writing... My English is not good. I learn many new words... but slow to check meaning in dictionary..."</i></p> <p><i>Subject 4 : "Yes, I agree with subject 3, writing is good practice but if teacher give time to write in class better. Sometimes I use new words in my essay but not sure right or wrong.. if write in class I can ask teacher."</i></p>

TABLE 12
Excerpt from Focus Group Interview: Question 3

<p>QUESTION 3: Do you think you will be able to use the new words you learnt during the focused in-class reading?</p> <p><i>Subject 4 : "I tried to use some in my summary...but not sure whether right or wrong."</i></p> <p><i>Subject 2 : "New words I learnt... I tried to use but sometimes...meaning not right. If teacher explain better than use dictionary alone".</i></p> <p><i>Subject 1 : "I more confident to use new words...but you know, may be I got it wrong but I don't care, I just use. I try experiment with new words".</i></p> <p><i>Subject 3 : "Writing summary is good for practice...emm ..and I can use new word so I can remember the meaning...but I need more time. Half hour for reading not enough..."</i></p>

TABLE 13
Excerpt from Focus Group Interview: Question 4

<p>QUESTION 4: Are you more confident in dealing with unknown words now compared to before the experiment?</p> <p><i>Subject 1 : "If I find new word I don't know... I just guess the meaning. If cannot guess, I check in dictionary...but like my friend say...sometime meaning not suitable."</i></p> <p><i>Subject 3 : "I not confident ...but I think I improve already compare to when I in secondary school."</i></p> <p><i>Subject 4 : "I know what should I do if I don't know the meaning of new words but I not confident. I need more practice."</i></p> <p><i>Subject 2 : "I more confident to check dictionary...I usually guess first from context like teacher say...I not worried if wrong meaning because it is not a test."</i></p>

group's mastery of vocabulary knowledge on average was 91.06% while the control group's mastery of vocabulary knowledge on average was 83%. According to Schmitt et al. (2001), a student has to score 80% (24 out of 30 correct answers) to pass each level of the VLT. Thus, both groups had passed the 2000-word level test. However, receptive vocabulary growth for the experimental group was higher than for the control group, showing a difference of 161 word families. Based on the result, it can be concluded that focused in-class reading with writing activity can promote larger receptive vocabulary growth compared to normal ESL lessons. Without intervention, the learners' receptive vocabulary growth is estimated to be 442 (221 per semester x 2) word families per year. The estimate is quite similar to the finding by Mokhtar et al. (2010), whose study recorded a growth rate of 440 word families per year. With intervention, a larger growth rate of 764 (382 per semester x 2) per year can be achieved.

Research Question 2

To address the second research question, the focus group interview data were analysed. It was concluded that the subjects perceived focused in-class reading plus writing activity as beneficial in improving their receptive vocabulary knowledge. In addition, the majority of the subjects interviewed proposed that summary writing be carried out as an in-class rather than out-of-class activity. Although most of the subjects admitted that they lacked the confidence to use the new words that they

had learnt productively (in their writing), they unanimously agreed that the writing activity had provided them with an avenue to enhance their knowledge of the newly acquired words.

CONCLUSION

Based on the analysis of the results it can be concluded that focused in-class reading with writing activity has the potential of promoting faster vocabulary growth. Although both the experimental and the control groups showed significant growth in their receptive vocabulary knowledge at the 2000-word level, the experimental group recorded a significantly higher growth compared to the control group.

The findings of this study are significant in two ways. Firstly, it provides evidence to support that general reading plus productive language activity such as writing in the target language can promote incidental learning of L2 vocabulary. Secondly, the study has pedagogical implications as it provides ESL teachers with an additional approach to ESL teaching which can be implemented to enhance L2 learners' receptive vocabulary knowledge. Since receptive knowledge of a word is a requirement of productive knowledge (Waring, 2002), improving L2 receptive vocabulary is a step towards developing their productive ability. In the study, the students were asked to write about what they had read every week. The act of writing (productive) is seen as an enhancement of the focused in-class reading activity (receptive). It was carried out to promote productive use of the new

vocabulary learnt during the focused in-class reading exercise. Finally, this study has demonstrated that a little effort on the part of an ESL teacher would go a long way to assist students in developing L2 vocabulary. The study proves that it is not the amount of time spent on reading that matters but how focused the students are during the act of reading that determines their level of success.

REFERENCES

- Abdullah, S., Abdul Rahim, P. R.M., Setia, R., Mohamad, R., Ghazali, N., Sabapathy, E. et al. (2012). Reading for pleasure as a means of improving reading comprehension skills. *Journal Asian Social Science*, 8(13), 233-238.
- Adolphs, S., & Schmitt, N. (2004) Vocabulary coverage according to spoken discourse context. In Bogaards, P. and Laufer, B., editors, *Vocabulary in a second language*, Amsterdam: John Benjamins, pp.39-52.
- Annamalai, S., & Muniandy, B. (2013) Reading habit and attitude among Malaysian polytechnic students. *International Online Journal of Educational Sciences*, 5(1), 32-41.
- Day, R. R., Omura, C., & Hiramatsu, M. (1991). Incidental EFL vocabulary learning and reading. *Reading in a Foreign Language*, 7(2), 541-551.
- Dermawan, A. (2013, Oct 26). National Library conducts survey on Malaysian reading habit next year. *The New Straits Times*. Retrieved on November 4, 2013 from: <http://www.nst.com.my/latest/national-library-conducts-survey-on-malaysian-reading-habit-next-year-1.385666#ixzz2jeR1iS5D>
- Eckerth, J., & Tavakoli, P. (2012). The effects of word exposure frequency and elaboration of word processing on incidental L2 vocabulary acquisition through reading. *Language Teaching Research*, 16(2), 227-252.
- Fan, M. (2000). How big the gap and how to narrow it? An investigation into the active and passive vocabulary knowledge of L2 learners. *RELC Journal*, 31(2), 105-119.
- Gallego, M. T., & Llanck, M. D. P. A. (2009). Exploring the increase of receptive vocabulary knowledge in the foreign language: A longitudinal study. *International Journal of English Studies (IJES)*, 9(1) 113-133.
- Goulden, R., Nation, P., & Read, J. (1990). How large can a receptive vocabulary be? *Applied Linguistics*, 11(4), 341-363.
- Horst, M., Cobb, T., & Meara, P. (1998) Beyond a clockwork orange: Acquiring second language vocabulary through reading. *Reading in a Foreign Language*, 11, 207-23.
- Jamian, L. S., Sidhu, G. K., & Muzafar, M. (2008). Assessing UiTM TESL students' knowledge of vocabulary. *Asian Journal of University Education*, 4(2), 79-100.
- Jenkins, J. R., Stein, M. L., & Wyoski, K. (1984). Learning vocabulary through reading. *American Educational Research Journal*, 21, 767-787.
- Karim, N. S. A., & Hasan, A. (2007). Reading habits and attitude in the digital age: Analysis of gender and academic program differences in Malaysia. *The Electronic Library*, 25(3), 285-298.
- Krashen, S. (1993). *The power of reading. Insights from research*. Englewood: Co.: Libraries Unlimited.
- Laufer, B. (2003). Vocabulary acquisition in a second language: Do learners really acquire most vocabulary by reading? Some empirical evidence. *Canadian Modern Language Review*, 59(4), 567-587.
- Mokhtar, A. A., Rawian, R. M., Yahaya, M. F., Abdullah, A., Mansor, M., & Osman, M. I., et

- al. (2010). Vocabulary knowledge of adult ESL learners. *English Language Teaching*, 3(1), 71-80.
- Nagy, O., Anderson, R. & Herman, P. (1987) Learning word meanings from context during normal reading. *American Educational Research Journal*, 24, 237-270.
- Nagy, W. E., & Scott, J. A. (2000). Vocabulary processes. In M. L. Kamil, P. B. Mosenthal, P. D. Pearson & R. Barr (Eds.), *Handbook of reading research* (Vol. 3, pp. 269-284). Mahwah, NJ: Erlbaum.
- Nation, I. S. P. (2001). *Learning vocabulary in another language*. Cambridge, UK: Cambridge University Press.
- Nation, I. S. P. (2006). How large a vocabulary is needed for reading and listening? *The Canadian Modern Language Review*, 63, 59-81.
- Nation, I. S. P. (1990). *Teaching and learning vocabulary*. Boston, MA: Heinle & Heinle Publishers.
- Nation, P., & Waring, R. (1997). Vocabulary size, text coverage and word lists. In Schmitt, N. & McCarthy, M. (Eds.), *Vocabulary: Description, acquisition and pedagogy*. Cambridge; New York: Cambridge University Press. pp. 6-19.
- Noor, N. M. (2011). Reading habits and preference of EFL post graduates: A case study. *Conaplin Journal: Indonesian Journal of Applied Linguistics*, 1(1), 1-8.
- Peters, E., Hulstijn, J.H., Sercu, L., & Lutjeharms, M. (2009). Learning L2 German vocabulary through reading: The effect of three enhancement techniques compared. *Language Learning*, 59, 113-51.
- Pitts, M., White, H., & Krashen, S. (1989). Acquiring second language vocabulary through reading.
- Rahim, P. R. M. A., Shazila, A., & Shareena, M. H. (2007, December). A survey in reading habits in UiTM Perak. Paper presented at the 5th UiTMT Academic Conference, Terengganu Equastrian Resort.
- Read, J. (2000). *Assessing vocabulary*. United Kingdom: Cambridge University Press.
- Schmitt, N. (2008). Instructed second language vocabulary learning. *Language Teaching Research*, 12, 329-63.
- Schmitt, N., Schmitt, D., & Clapham, C. (2001). Developing and exploring the behaviour of two new versions of the vocabulary levels test. *Language Testing*, 18, 55-88.
- Waring, R. (2002). Scales of vocabulary knowledge in second language vocabulary assessment. *Kiyo, The occasional papers of Notre Dame Seishin University*.
- Waring, R., & Nation, P. (2004). Second language reading and incidental vocabulary learning. *Angles on the English-speaking World*, 4, 11-23.
- Yammamoto, Y. (2011). Bridging the gap between receptive and productive vocabulary size through extensive reading. *The Reading Matrix*, 11(3), 226-242.

Developing Students' Creative Response to Literary Texts in the ESL Classroom

Adzura Elier Ahmad^{1*} and Li Sheau Juin²

¹*Faculty of Education, Universiti Teknologi MARA, Shah Alam, Selangor, Malaysia*

²*Sekolah Menengah Kebangsaan Datok Lokman, Kuala Lumpur, Malaysia*

ABSTRACT

The emergence of the literature component as a compulsory tested component of the Malaysian ESL syllabus for secondary schools is one of the most significant developments in ESL learning in recent years. One of the general aims of incorporating literature in an ESL classroom is to enhance students' proficiency and enjoyment of the English language through literature. One of the biggest challenges in the ESL classroom is making learning meaningful, and project-based learning is but one of many ways to achieve this goal. The main focus of the Literature component in the Malaysian English curriculum is to fulfil academic requirements, but this does not preclude students' enjoyment of the texts or the experience of engaging with literary texts. Literary texts are wonderful materials that can be explored and exploited in the ESL classroom, for instance, for the development of writing skills. This study is based on the precepts of Project-Based Learning, which hinges on Constructivist ideals looking towards long-term student centred, activity-based learning framed by sequential acquisition of discrete skills through holistic and realistic learning. This study will be exploring the acquisition of skills and language as part of holistic learning through the staging of a play. The most pertinent findings are that PBL as it is applied here allowed the students to focus on the impending stage production as both an outcome and a motivation to acquire skills. It found that as the curriculum requirements of reading, writing, listening and speaking were no longer abstract personal choices but rather skills the students were acquiring in the pursuit of completing the project, the students significantly improved in their commitment to acquiring and in the practice of language skills and

holistic values such as self-confidence, team work and perseverance. The findings were most eloquently supported in the students' own words in their journals as they tracked their progress and setbacks from the

ARTICLE INFO

Article history:

Received: 2 January 2012

Accepted: 3 March 2014

E-mail addresses:

adzura@hotmail.com (Adzura Elier Ahmad),

sheaujuinli@gmail.com (Li Sheau Juin)

* Corresponding author

beginning of the year until the end of the project and the release of the results of their final exams. As writing is a difficult skill to master, this study supports both the concept of language acquisition in practice as well as fulfilling the school-based assessment skill building requirement in a cohesive construct that provides focus and reward for the students as well as breaks the monotony of conventional classroom teaching. At the very least, it offers teachers some of the possible strategies or activities using literary texts used in schools to develop English communication in the four areas, with special focus on writing skills. It also examines the students' learning process in producing pieces of writing in response to reading a literary text, their response to performing as a post-writing activity, and the implications of using drama and plays as a post-writing activity. The ready-made year-end school performance for teachers provided in this paper is also a bonus.

Keywords: Project based learning, teaching writing, facultative teaching and learning, performance learning, fun with literature teaching approach

INTRODUCTION

The Education Ministry of Malaysia continues to initiate changes in mitigating the pressures facing the nation after the policy of Teaching Mathematics and Science in English or PPSMI was reversed. In an effort to address concerns over declining English proficiency among the population, the “Upholding the Malay Language and Strengthening Command of English”

(MBMMBI) policy was instituted. In 2012, in an effort to ensure that no Malaysian child is left behind in the education system, the English Language Curriculum was designed to be more skills-based, ensuring that each child in Malaysian government schools would acquire the minimum level of skills specified in the standard for that year under the new school curriculum standards respectively termed KSSR for primary schools and KSSM for secondary schools. The fundamental concern was to get learners to be more involved in and have a sense of ownership and accountability over their learning. One challenge ESL teachers face is trying to make the English language seem less foreign or arduous for students to learn, and where possible, to ensure the process of learning the language is more natural and fun. The Ministry of Education in Malaysia takes this so seriously that a special module termed Language Arts has been incorporated in the English language curriculum and decided that the Literature Component would be tested. The proviso for teachers was that implementation of Language Arts would still have to provide augmentation for the actual skills needed for the students fulfil their academic requirements.

Project Based Learning as an Authentic Language Learning Experience

Authentic learning is a pedagogical approach that advocates a less regimented style of learning that promotes multidimensional learning where several core subjects (or areas within a subject) simultaneously work together towards incorporating the

acquisition of technical skills, research skills and communication skills (Mims, 2003). If one were to accept the three core principles towards ensuring lasting learning as discussed in Hooper and Rieber's article "Learning for the 21st Century" (Hooper, 1995) then presenting information from multiple perspectives increases the durability of instruction and effective instruction that should build upon students' knowledge and experiences. It would be grounded in meaningful contexts, which teachers could then extrapolate to create a situation or condition which incorporates both the former by Mims (2003) and the latter by Hooper (1995), and could be instrumental in achieving the objectives of KSSR and KSSM set by the Malaysian Education Curriculum.

Proponents of Authentic Learning believe it contributes significantly to making learning more effective and helps learners acquire skills applicable in real life (Newmann, Marks, & Gamoran, 1996). Project-Based Learning (PBL) is an approach that encapsulates these principles on a scale that can be incorporated in Malaysian classrooms. It is based in constructivism and constructionism, which takes the notion of individuals constructing knowledge one step further by positing that they (the learners) learn best when doing so by sharing the process with others and reflecting upon the process as well as the outcome (Grant, 2002). Project-based learning also addresses the 10 key characteristics of authentic learning activities as defined by Herrington, Oliver and Reeves (2003) as having real

world relevance, requiring the learners to define smaller tasks and subtasks needed to complete the activity. PBL comprises complex tasks to be investigated by students over a sustained period of time, which subsequently provides the opportunity for students to examine the tasks from different perspectives, using a variety of resources. Aside from providing the opportunity to collaborate, it also provides the learners with the opportunity to reflect; thus, it is able to be integrated and applied across different subject areas and lead beyond domain-specific outcomes. It is able to be seamlessly integrated with assessment, creating polished products valuable in their own right (rather than a preparation for something else in a vacuum such as the traditional pen and paper examination) as well as allowing for competing solutions and diverse outcomes. Grant (2002) continues that an important element to constructionism is that it must be personally meaningful: it should be more likely for individuals to become engaged in learning, which is central to the PBL process as well as its outcome.

However, integrating PBL in the Malaysian English Language classroom is a challenge on multiple levels of preparation, logistics, resources and the teachers themselves as it requires teachers to relinquish a certain degree of control to free the learners to experiment and explore. According to Grant (2002, p. 3) each model of successful project-based learning shares these features:

1. An introduction to “set the stage” or anchor the activity;
2. A task, guiding question or driving question;
3. A process or investigation that results in the creation of one or more shareable artifacts;
4. Resources, such as subject-matter experts, textbooks and hypertext links;
5. Scaffolding, such as teacher consultation to help learners assess their progress, project templates, conferences to redirect efforts, mediate issues, and even to motivate flagging spirits;
6. Collaborations, including teams, peer reviews and external content specialists; and
7. Opportunities for reflection and transfer, such as classroom debriefing sessions, journal entries and extension activities.

Addressing the pivotal roles of the teacher in this process, Mims (2003, p. 2) delineated these practical implementation tips:

1. *You must think like a coach.* Authentic instruction calls upon you to take on a different role than traditional (Asian) teaching methods. Students need to be given control over their learning and it is important that the teacher does not micro-manage or take away that sense of empowerment.
2. *Bring earplugs.* Teachers must accept that the classroom environment will change drastically. Students will be

actively working, participating in discussions, hunting for information as well as resources and they would be enjoying the freedom of the entire process. It will become very important that teachers help students to be responsible in managing the new energetic and flexible dimensions of learning.

3. *Ease your way into it.* Perhaps undertaking a two-week authentic experience in the beginning may not be a good idea, both for the teacher as well as the learner. It is imperative for all to become acclimatised positively and constructively to this process.
4. *Get some help.* There are quality examples and resources to help with the design of authentic instruction. It may also be a good idea to start off with more than one adult in the process, get another teacher or volunteer parent to help in the beginning.
5. *YOU are learning too.* Think of the first attempt as a learning experience for you (Mims, 2003).

It is essential to note and prepare for the likelihood that most teachers and learners who were products of the traditional classroom especially teacher-orientated cultures may exhibit significant resistance to the sudden change of practice (Grant, 2002). There will also be a period of mutual adjustment and negotiation of responsibility and/or accountability on the part of the learners themselves (Mims, 2003). In the interest of addressing these concerns,

this study investigates the possibility and reality of implementing PBL as an authentic learning experience for the ESL classroom in Malaysia, specifically in the teaching and learning of the literature component under Language Arts.

The following is a case study of PBL implementation in an English classroom of a Malaysian secondary school in the Klang Valley. The researcher is their English Language teacher who is currently enrolled in PhD research in this field. In the process of conducting the study, the following research questions were posed

1. Does PBL affect students' willingness to engage with the literary text?
 - Do script writing and drama activities enhance the students' creative and critical writing skills?
2. How do the activities they engage in, which are associated with the process of performing, help students comprehend the literary text?

The objectives of this study are to:

- Examine students' learning processes in writing and performing a script in response to a literary text.
- Evaluate the implications of using dramas and plays as a Literature component in the ESL classroom.

METHODOLOGY

This research employs a case study approach to explore the development of creative responses to literature texts in the ESL classroom. A qualitative design is selected

as it allows the researcher to interpret, explain and decode the meaning of the social process in context-bound language (Merriam, 1998). It allows the researcher to explore PBL as a catalyst to the development of *creative response* to the literature texts in the ESL classroom. A qualitative case study research as defined by Merriam (1998) is an intensive, holistic description and analysis of a bounded phenomenon" (p. xiii). Yin (2003) provides more specific boundaries for case study. It is an empirical inquiry that investigates a contemporary phenomenon within its real-life context, especially when the boundaries between phenomenon and context are not clearly evident.

The case study approach is selected for this study because it can provide a vivid and full description of a single case. In the case of implementing a PBL approach, it provides depth to the specific stages in the process involved. According to Salkind (1997), it allows for close examination and scrutiny of the collection of a great deal of detailed data. In addition, it is convenient in exploring the subjects' thoughts, learning experiences through group work, peer conferencing and learning outcomes, which would not be possible through quantitative methods.

Therefore, multiple measures to collect data common in case studies such as reflective journals, drafts of the script and the edited script enabled the researcher to examine closely the thought processes of the subjects in relation to the process of script writing to the presentation of the drama. In order to encourage students to be at ease

with the journal-writing process, minimal restrictions and requirements imposed upon them. The reflective journals enabled the researcher to keep a record of the development of the study over time. It gave the researcher insight into their reading, writing, feelings, strengths and weaknesses.

Selection of Subjects

The subjects for this study consisted of 37 Form Three students from a secondary school in Kuala Lumpur as the researcher taught only Form Three classes, and these were the only classes she had access to in order to implement PBL. These students had read three short stories and three poems in Form One and one novel each in the Form Two and Form Three as part of the Literature Component of the English Language Curriculum. As their previous teachers had completed the syllabus requirement, they were assumed to be accustomed to reading and discussing literary texts. The students were, in general, of intermediate level of proficiency in the English language, with the exception of 13 students who were of a higher level. This classification is based on their scores in the Literature section of the Final Year examination the year before. The section consisted of multiple-choice questions based on one of the poems studied in Form Two as well as an open-ended question based on the novel studied in the same year.

The ethical considerations were addressed on three levels; the Principal of the school involved had agreed to allow the

study to be carried out in the school and the students involved had been informed of the nature of this research and that it was also part of their literature component lessons. Permission slips to parents were later given to students who wished to stay back after school to discuss their work with their teacher or with their own group members. However, they were not allowed to do so without the presence of their teacher.

The process of script writing to the presentation of the drama was carried out in three stages over the period of 12 weeks. The students were divided into groups of eight, with each group preparing a script for two chapters of the novel. The students would use samples of scripts written for plays and dramas, either provided by the teacher or sourced themselves. The researcher met the students twice a week during their Literature lessons where she advised them on the mechanics of script writing. Permission slips from parents were collected beforehand from students who wanted to stay after school to continue their work with the teacher to check on their progress. Many of the students' queries were on choice of words and use of phrases and expressions to express the narrative in dialogue form. Data to track their progress were collected in the form of the students' drafts of their scripts and their journals.

Stage one - text selection and script writing

The first step was to allow the students to choose their own story, as it would give

them the feeling of control over their reading. Gambrell (1996) asserts that the self-selection of reading materials supports the notion that the books and stories that children find 'most interesting' are those they have selected for their own reasons and purposes. The students had unanimously agreed to prepare their drama based on the abridged version of the novel 'Phantom of the Opera' by Gaston Leroux which they had studied in Form Two.

The script-writing process was carried out in two weeks where the team of writers would meet with their teacher twice a week to discuss their draft. It is thought that the process of adapting text to script encourages students to synthesise what they know about the characters and authors by placing them in new situations. It aims to help students to discover a need to express what is important to them as a personal and creative response, and not to repeat learned responses. The writers would use samples of scripts written for plays and dramas. They were also advised on the mechanics of script writing appropriate to their level by their teacher. The drafts were collected as data once the final script was done.

Stage two - preparation and rehearsals

At this stage, the students had now formed groups to handle backstage work (back drop and props, costume and sound effects) as the written scripts were being compiled by the director of the drama, who was one of the students picked by the class. Once the script was completed, every student received a copy. Facilitated by their teacher

(the researcher), a simple audition was carried out to decide on the actors. Then, the students read and discussed the script with the director as well as their teacher. Working in small groups, the students were briefed by the director and then started preparing for the presentation of the drama. Backdrop and costumes were made and sound effects were set. Students who had roles in the drama had the task of remembering their lines and rehearsing the drama presentation.

Each group was required to keep a journal throughout the preparation process. The journals would include:

- Dates of entries
- Changes made in the script
- Suggestions initiated by team members
- Comments made by the team members

The purpose of the journals was to provide a record of the group discussions, images and ideas projected during the meetings and rehearsals. It is a method of tracking students' input and output that is permanent and equitable as it allows for the shy, quiet or introverted students to 'have a say' as they tend not to speak up in a shared verbal forum. It also needs to be noted that as they gained ownership over their specified tasks and roles, the students were more confident in verbalising and defending their views or choices.

The researcher's role was that of facilitator, who ensured that the students were supported throughout the process as well as in their interactions. To do so, the researcher closely monitored their progress,

discussed or refereed when the need arose. All this was recorded in the students' journals.

Stage three - the performance

The final stage of the performance process required the students to vacillate from script writing to drama presentation. Their performance during rehearsals would have been continuously amended as their vision and understanding deepened, requiring the class to work together at all levels and in all areas of responsibility so that their final product would be cohesive, coherent and ultimately entertaining as well as enlightening. The drama was performed in front of an audience that consisted of other Form Three students as well as the English Language teachers. The performance was recorded and later viewed by the students.

Students' reflections

At the end of the whole process, the students were required to write a reflective journal. The journals would assist the students to clarify, evaluate and reframe their thoughts, feelings and actions in light of their own experience as well as the information encountered in the study.

The reflective journal served as a mechanism to:

- Gain deeper insight particularly into the subjects' thoughts and feelings about the project they were involved in
- Probe further into the subjects' views on the process of script writing to the

presentation of the drama and discuss issues that may have been missed out in the group journals and

- Help the subjects become more aware of the skills they have acquired as they reflect on the experience derived from their participation in the study.

In the beginning stages, the students displayed the basic ability of describing and reporting their views of how they came to choose the novel 'Phantom of the Opera', which they had studied the year before, over 'Dr Jekyll and My Hyde' read in the current year. They were aware of the thoughts and feelings of the rest of their classmates in making their choice.

When my teacher asked us to put up a play, she gave us two choices, 'Phantom of the Opera' or 'Dr Jekyll and Mr Hyde'. The whole class chose 'Phantom of the Opera' because they liked the kissing scene.
– Deepah

Students also expressed their enthusiasm about the performance, stating that they could not wait for the script to be ready so that they could start practising.

I was very excited because I played the role of La Carlotta in our class play 'Phantom of the Opera'. ...I was really nervous on the first day of practice... I've never been in a play before. – Sharifah Shazlina

The students who were not comfortable performing on stage volunteered to work backstage and preparing the props needed for the performance.

I was so relieved that I was not chosen to be one of the actors! I just want to be the props guy. – Yusof

The freedom to make those changes during the script-writing activity allowed the students to have a certain amount of control over what would be performed, giving them a purpose for writing.

... everyone sudden has tons of ideas to give now that the script has been written. Rayme suggests we change the notes from the phantom to emails. Adli thinks that instead of Madame Giry talking face to face with the directors, she should speak to them on her handphone...-- Farng Hui

The entries reflected their engagement with the story on a level beyond superficial memorisation. Allowing them to take the text and adapt the story as they felt appropriate throughout the process ensured that the students completed the final process of meaningful learning as previously discussed by Grant (2002) on the need for the learner to share in the experience of knowledge discovery and reflect upon his/her journey throughout the process.

The researcher also found that the project fulfilled the academic requirement

of the curriculum as evidenced from the clearly improved personal-response answers in the Literature Component of their test by the students involved. These were echoes of the same students' feedback regarding the experience in their journals.

Yusuff let go of the chandelier a little too soon but we managed to carry on with our performance without stopping. – Langran

I can't begin to describe how I feel right now. All I can say right now is, I LOVE MY CLASS! –Aqilah

IMPLICATIONS AND RECOMMENDATIONS

Given the observable improvement in several areas of the students' abilities, it would seem that engaging in PBL has helped in this particular instance. Based on evidence seen in terms of the students' general enthusiasm for the material, increased participation in the activities they engaged in relation to the process; which in the study was demonstrated by their more organic responses (in the sense that they are able to show growing understanding during the course of the study) in the journal instead of regurgitation of the memorized answers from their textbooks or workbooks, in their ability to contribute to the performance of the play whether technically using sound, lights, props and various other means or artistically in the writing of the script, directing the play or performing it. There is evidence from other studies that

would support the value of using PBL as authentic-learning classroom practice. Frank and Barzilai (2006) have stated that the importance of student engagement is widely accepted, and numerous researchers have provided considerable evidence to support the effectiveness of student engagement on a broad range of learning outcomes and skills acquisition (Prince, 2004; Hake, 1998; Redish, Saul, & Steinberg, 1997; Laws, Sokoloff, & Thornton, 1999). Bonwell and Eison (1991) summarised the literature on active learning and concluded that it leads to better student attitudes and improvements in students' thinking and writing. This conclusion is supported by the subjects in this study, who were from the lower-proficiency classes and who, although previously resistant to using English, managed to put up a play organised by them. According to Hill and Smith (1998), given the complexity of student abilities in relation to their demographics, students must be guided through the process. Green (1998) noted that project-based learning increases motivation to study and helps students to develop long-term learning skills. Students know that they are full partners in this learning environment and share the responsibility for the learning process. In some studies, a positive correlation was found between self-esteem and receiving a positive assessment (Battle, 1991). Hill and Smith (1998) also found that the PBL environment in their courses increased students' self-confidence, motivation to learn, creative abilities and self-esteem. Given that a large proportion of English teachers in Malaysian schools may

not be familiar with PBL, a possible issue would be to recognise how a project may be an opportunity for PBL. The introduction of school-based assessment policy in Malaysian schools may be the opportunity to integrate PBL in the language-learning experience of Malaysian students.

PBL projects are focused on questions or problems that 'drive' students to encounter (and struggle with) the central concepts and principles of a discipline. This criterion is a subtle one. The definition of the project (for students) must "be crafted in order to make a connection between activities and the underlying conceptual knowledge that one might hope to foster" (Barron, Schwartz, Vye *et al.*, 1998, p. 274). This is usually done with a "driving question" (Blumenfeld *et al.*, 1991) or an ill-defined problem (Stepien & Gallagher, 1993). PBL projects may be built around thematic units or the intersection of topics from two or more disciplines, but that is not sufficient to define a project. Every aspect such as the questions that students pursue, as well as the activities, products and performances that occupy their time, must be "orchestrated in the service of an important intellectual purpose" (Blumenfeld *et al.*, 1991, p. 373). It is also important to impress upon teachers that PBL requires projects that involve students in a constructive investigation. An investigation is a goal-directed process that involves inquiry, knowledge building and resolution. Investigations may be design, decision-making, problem-finding, problem-solving, discovery or model-building processes. But, in order to be considered as

a PBL project, the central activities of the project must involve the transformation and construction of knowledge (by definition: new understandings, new skills) on the part of students (Bereiter & Scardamalia, 1999). If the central activities of the project represent no difficulty to the student or can be carried out with the application of already-learned information or skills, the project is an exercise, not a PBL project. This criterion means that straightforward service projects such as planting a garden or cleaning a stream bed are projects, but may not be PBL projects. In the context of an ESL classroom, planning the execution of the adaptation of the play, including the writing of the script, casting and organising the play provided the students an opportunity to manifest skills in all four areas of reading, writing, listening and speaking in addition to calling upon them to merge technological know-how, real life problem-solving and social negotiation skills with English language use in fulfilling their tasks as part of the various production teams.

CONCLUSION

It is possible to implement PBL in the ESL classroom as an effort to generate a creative response in an authentic learning opportunity which calls on learners to manifest their use of the English language as a natural progression from their learning in different areas at the different stages of the project. This particular study afforded an example of how PBL provided authentic learning in the process of putting up a play. To reiterate what was mentioned in

the implications section of this paper, that exercise also provided opportunities for learners to acquire and manifest a host of real-life social and technological skills with the culmination of the final performance as the central goal. The question now is whether teachers in Malaysian schools would be doing so with the opportunity afforded in the newly-implemented school-based assessment policy.

REFERENCES

- Bonwell, C. C., & Eison, J. A. (1991) Active learning: Creating excitement in the classroom. *ASHE ERIC Higher Education Report (1)*. Washington DC: George Washington University.
- Bossert, S. T. (1998/1989). Cooperative activities in the classroom. *Rev Res Educ*, 15, 225-250.
- Bransford, J. D., Brown A. L., & Cocking R. R. (Eds.). (1999). *How people learn: Brain, mind, experience, and school*. Washington, DC: National Academy.
- BUCK Institute for Education (1999). *PBL overview*. Accessed online on 17 March 2011 from: <http://www.bie.org/pbl>.
- Frank, M., & Barzilai, A. (2006) Project-based technology: Instructional strategy for developing technological literacy. *Journal of Technology Education* 18(1), 40.
- Grant, M. (2002). Getting a grip on project based learning: Theory, cases and recommendations. *Meridian: Middle School Computer Technology Journal*, 5(1), 1. Accessed online on March 15, 2011 from: <http://www.ncsu.edu/meridian/win2002/514/index.html>
- Green, A. M. (1998). *Project-based-learning: Moving students toward meaningful learning*. (ERIC Document Reproduction Service No. ED422 466).

- Herrington, J., Reeves, T. C., & Oliver, R. (2007). Immersive learning technologies: Realism and online authentic learning. *Journal of Computing In Higher Education*, 19(1), 65-84.
- Herrington, J., Oliver, R., & Reeves, T.C. (2003). Patterns of engagement in authentic online learning environments. *Australian Journal of educational Technology*, 19(1), 59-71.
- Hill, A. M., & Smith, H. A. (1998). Practices meet theory in technological education: A case of authentic learning in the high school setting. *Journal of Technology Education*, 9(2), 29-41.
- Hooper, S., & Rieber, L. P. (1995). Teaching with technology. *Teaching: Theory into practice* (pp. 154-170). Needham Heights, MA: Allen and Bacon.
- Johnson, D., Johnson, R., & Smith, K. (1998). Cooperative learning returns to college: What evidence is there that it works? *Change*, 30(4), 26-35.
- Mims, C. (2003). Authentic learning: A practical introduction and guide for implementation. *Meridian: Middle School Computer Technology Journal*, 6(1), 2. Accessed online on March 15, 2011 from http://www.ncsu.edu/meridian/win2003/authentic_learning/
- Newmann, F. M., Marks, H. M., & Gamoran, A. (1996). Authentic pedagogy and student performance. *American Journal of Education* 104(8), 280-312.
- Stage, F. K., Kinzie, J., & Simmons, A. (1998). Creating learning-centred classrooms: What does learning theory have to say? *ASHE ERIC Higher Education Report 26* Washington DC, George Washington University: Graduate School of Education and Human Development.

Teachers' Self-Efficacy in Teaching Family Life Education

Rahimah, J.^{1*}, Abu, R.¹, Ismail, H.² and Mat Rashid, A.¹

¹Department of Science Technical, Faculty of Educational Studies, Universiti Putra Malaysia, 43400 UPM Serdang, Selangor, Malaysia

²Department of Foundation of Education, Faculty of Educational Studies, Universiti Putra Malaysia, 43400 UPM Serdang, Selangor, Malaysia

ABSTRACT

Although the notion of self-efficacy has been applied to many domains, little is known regarding teacher efficacy in teaching family life. Self-efficacy in this study refers to teachers' beliefs that their efforts can improve students' moral characters and behaviors in relation to family life. In Malaysian secondary schools, aspects of family life are taught through five different subjects. Therefore, there is a need for studying teachers' self-efficacy in teaching family life, which is the main purpose of this research. In this research, the Teachers' Sense of Efficacy Scale, developed by Tschannen-Moran and Woolfolk Hoy (2001), was used to measure teachers' self-efficacy. Data was collected from 419 secondary school teachers who teach family life. Findings indicated that respondents had moderate self-efficacy for the overall teaching efficacy as well as three sub dimensions of efficacy. The implication of the study is discussed in the last part of the paper. Suggestions offered are hopefully to be considered to enhance and foster teacher efficacy in teaching family life.

Keywords: Teachers' efficacy beliefs, teachers' sense of efficacy, Family Life Education

ARTICLE INFO

Article history:

Received: 13 August 2012

Accepted: 21 September 2012

E-mail addresses:

imah_upm@yahoo.com (Rahimah, J.),

rosini@upm.edu.my (Abu, R.),

habsah@upm.edu.my (Ismail, H.),

abmr@upm.edu.my (Mat Rashid, A.)

* Corresponding author

INTRODUCTION

Individuals' beliefs play an important role with regard to their behaviors. The realization of our objectives is based on our beliefs about how we can behave successfully. Individuals judge their own capabilities according to their own actions (making a decision about a certain task, making or exerting an effort to accomplish a task, or confronting difficulties). All these

play an important role in understanding one's self-efficacy beliefs.

The concept of a teacher's self-efficacy has gained much attention in recent years (Siti Safariah, 2009; Abd. Rahim, Mohd. Majid, Rashid, & Novel, 2008; Cheung, 2008; Tschannen-Moran & Hoy, 2007; Wolters & Daugherty, 2007). Beginning with research done in the 1970s, a teacher's self-efficacy was first conceptualized as his or her general capacity to influence students' performance (Allinder, 1995, p. 247). Since then, the concept of a teacher's self-efficacy has developed continuously. Bandura (1995) defined self-efficacy as "beliefs in one's capabilities to organize and execute the courses of action required to manage prospective situations." Tschannen-Moran and Woolfolk Hoy (2001) defined a teacher's efficacy as the teacher's "judgment of his or her capabilities to bring about desired outcomes of student engagement and learning, even among students who may be difficult or unmotivated" (p. 783).

Education research has suggested that teachers' self-efficacy has proven to be one of the most powerful predictors in determining student outcomes and effective teaching practice. In classrooms with teachers of high self-efficacy, students are more academically motivated, more likely to have high self-efficacy themselves, and more likely to achieve academic success (Angelle, 2002; Margolis & McCabe, 2006; Siegle & McCoach, 2007). In other words, students benefit from having teachers with high self-efficacy.

The powerful effects of self-efficacy can be seen in teachers' actions. A teacher's behavior varies with his or her self-efficacy beliefs. Teachers with high self-efficacy spend more time planning and organizing classroom activities and they are more open to new methods and ideas to meet students' needs. Teachers with high self-efficacy also are more likely to develop classrooms with mastery goal structures, use inquiry and student-centered teaching strategies, focus on learning and improvement, and view difficult students as reachable (Shidler, 2009; Wolters & Daugherty, 2007). In contrast, teachers with low self-efficacy devote more time to non academic matters, criticizing students for their failures and giving up on students who do not succeed. Teachers with low self-efficacy are also more likely to report higher levels of anger and stress and more likely to use teacher-directed strategies, such as lectures and readings from the text (Hoy, 2004; Kaufman & Sawyer, 2004).

THE IMPORTANCE OF FAMILY LIFE EDUCATION

Preparing individuals and families for roles and responsibilities of family living is nothing new. Traditionally, knowledge related to family roles and responsibilities was transmitted through non formal education, where much was learned in the family setting itself as family members observed and participated in family activities and interactions. However, in a more complex and changing society today, the development of new knowledge,

advances in technology, and changes in social conditions create circumstances in which this traditional method may not be appropriate or sufficient. Families must be supported in their educational efforts by activities of other institutions, such as schools (IPPF, 2011).

Family life is defined as an educational program designed to help prepare students for effective parenthood by learning about child development and the role of parents (IPPF, 2011). The purposes of the program are to help girls and boys gain knowledge about their growth, development, and reproduction, including changes that will occur during adolescence and responsibilities prior to parenthood. Education researchers have suggested several rationales for teaching family life. It is seen as a way of preparing families by providing adequate knowledge of dealing with social change, developing healthy and responsible relationships, enriching family life, and promoting the quality of family life. With regard to this, Dana (2002) in the project "Prepare Tomorrow's Parent" indicated that young people must be prepared not only for school work but also for the one occupation most of them will have parenthood. Therefore, to develop healthy and harmonious families for a better future, we must strengthen teaching and learning strategies to prepare future parents with adequate parenting knowledge and skills.

In Malaysia, aspects of family life are taught in secondary school through five different subjects: Home Economic,

Moral education, Physical and Health Science education, Civic and Citizenship education and Islamic education. The current Malaysian teacher education training programs require prospective teachers to complete coursework both in general education and in subject matter areas. At the moment, several drawbacks can be observed in the program for family life. First, there is no teacher education program specifically offered for family life education teachers. Teachers are introduced to topics related to family life through one or several subjects during usual teacher education programs. However, they are required to teach the aspects of family life through Home Economic education Moral education, Physical and Health Science education, Civic and Citizenship education, and Islamic education. Second, sometimes a non option teacher teaches one of these five subjects. Besides, the Curriculum Development Centre (2005) reported that teachers have problems in inculcating values in teaching and learning. They have difficulty making a connection between the content they teach with values observed and a lack of pedagogical knowledge relating values to the subject matter. This is due to insufficient knowledge and skills obtained during teacher education training. Since teaching family life is very much related to the calculation of student values, there is a need for studying teachers' self-efficacy in teaching family life.

PURPOSE OF THE STUDY

The purpose of the study was to determine secondary school teachers' self-efficacy in teaching family life. Specifically, the objective was to find out the level of self-efficacy in family life education teachers.

METHODOLOGY

Population and Sample

The sample selected to identify the level of self-efficacy in the family life education teachers consisted of five different options of teaching. There were teachers of Home Economic education, Moral education, Physical and Health Science education, Civics and Citizenship and Islamic education. The sample included 73 of Home Economics teacher, 72 of Moral education teacher, 93 of Physical and Health Science education teacher, 89 of Civics and Citizenship education teacher and 92 of Islamic education teachers.

Instrumentation

The Teachers' Sense of Efficacy Scale (TSES), developed by Tschannen-Moran and Woolfolk Hoy (2001), was used in this study. The inventory consisted of 24 items with three sub dimensions (instructional strategies, classroom management, and student engagement) and was measured using a 9-point likert scale: 1 (nothing), 3 (very little), 5 (some influence), 7 (quite a bit), and 9 (a great deal). Each sub-dimension of the inventory consisted of eight items. This inventory was adapted to Bahasa Malaysia by Rahmah (2005) using

back-to-back translation. Cronbach' alpha coefficient for the overall inventory was .96, efficacy in instructional strategies .91, efficacy in classroom management .86, and efficacy in student engagement .91. The scores obtained showed a high degree of reliability.

Data Collection and Analysis

Prior to data collection, approvals were obtained from the Educational Planning and Research Division (EPRD), Ministry of Education Malaysia; the State Department of Education; and school principals. Survey questionnaires were sent to principals of selected schools, who later distributed them to appropriate teachers selected as respondents on the basis of the criteria set by the researcher. The survey questionnaires included the Teachers' Sense of Efficacy Scale and questions about the respondents' backgrounds. The completed data was analyzed using descriptive analysis to get the mean ratings of efficacy and its three sub-dimensions.

RESULTS

Profile of Respondents

Of the 419 respondents, 319, or 76.1%, teachers were female, with the majority being Malay teachers. A total of 53.2% were teaching in urban schools, having less than five years of experience in teaching family life, with a mean of 6.75 years of experience in teaching family life. There were 60 (14.3%) respondents who had no experience in teaching family life.

The study also showed that 53.7% of the respondents taught in areas of their subject options, while 46.3% of the respondents did not get an opportunity to teach according to their subject options. The average age of the respondents was 39.26 years. The demographic profile indicated an uneven distribution of teachers between the subjects taught and their teaching subject options, gender, and teaching experiences.

Teaching Efficacy of Secondary School Teachers in Family Life Education

As shown in Table 3, the findings of this study show that the mean for the overall self-efficacy of secondary school teachers in teaching Family Life education was 6.43, with a standard deviation (SD) of .81. The self-efficacy mean for instructional strategies was 6.55 (SD .91), classroom management 6.59 (SD .87), and student engagement 6.14 (SD .83). In comparing

TABLE 1
Demographic profile of respondents

Characteristic	Frequency (n=419)	Percentage
Gender		
Male	100	23.9
Female	319	76.1
Ethnicity		
Malay	380	90.7
Chinese	11	2.6
Indian	25	6.0
Other ethnic	3	0.7
School locality		
Urban	223	53.2
Rural	196	46.8
Age (Mean: 39.26) (SD= 7.79)		
Less than 30 years	63	15.0
31 to 39 years	156	37.2
40 to 48 years	142	33.9
49 years and above	58	13.8
Experience in teaching family life (Mean: 6.75) (SD= 6.91)		
No experience	60	14.3
less than 5 years	156	37.2
5 to 15 years	133	31.7
More than 15 years	70	16.7
Teaching subject option		
Non option teacher	194	46.3
Option teacher	225	53.7

TABLE 2
Demographic profile of teachers who taught family life

Characteristic	Home Economic		Moral		Health		Civic		Islamic	
	n	%	n	%	n	%	n	%	n	%
Age										
< 30	8	11.0	15	20.8	15	16.1	21	23.6	4	4.3
31– 39 years	20	27.4	28	38.9	39	41.9	32	36.0	37	40.2
40 – 48 years	23	31.5	21	29.2	32	34.4	29	32.6	37	40.2
> 49 years	22	30.1	8	11.1	7	7.5	7	7.9	14	15.2
Total	73	100	72	100	93	100	89	100	92	100
Experience in teaching family life										
No experience	4	5.5	17	23.6	17	18.3	14	15.7	8	8.7
< 5 years	16	21.9	35	48.6	34	36.6	62	69.7	9	9.8
5-15 years	29	39.7	15	20.8	29	31.2	12	13.5	48	52.2
> 15 years	24	32.9	5	6.9	13	14.0	1	1.1	27	29.3
Total	73	100	72	100	93	100	89	100	92	100
Teaching subject option										
Option teacher	62	84.9	19	26.4	50	53.8	2	2.2	92	100
Non option teacher	11	15.1	53	73.6	43	46.2	87	97.8	-	-
Total	73	100	72	100	93	100	89	100	92	100
Teaching subject										
Major	56	76.7	17	23.6	35	37.6	7	7.9	92	100
Minor	17	23.3	55	76.4	58	62.4	82	92.1	-	-
Total	73	100	72	100	93	100	89	100	92	100

the three sub dimensions of self-efficacy, results indicate that the respondents had the highest efficacy in classroom management and the lowest in student engagement. Table 4 indicates that the overall efficacy mean score was the highest for Islamic education teachers and the lowest for Civic and Citizenship education teachers in all three sub dimensions.

DISCUSSION

Overall, this study provides insight into how teachers perceive their self-efficacy

in teaching Family Life education. The results of this study show that self-efficacy of secondary school teachers in teaching family life is high. The majority of the respondents have a high efficacy in all three sub-dimensions of self-efficacy, especially classroom management. The findings are consistent with those of Siti Safariah (2009), Abd. Rahim *et al.*, (2008), and Teng (2006). The results of this study are also in line with previous research (Cakiroglu, Cakiroglu, & Boone, 2005; Cheung, 2008), which reported that teachers perceive themselves as having high efficacy. Cheung (2008) and Kotaman

TABLE 3

The mean scores and standard deviation of secondary school teachers' efficacy for three levels of efficacy and the respective sub-dimensions (N=419)

Factors	Mean	SD
Overall Teacher Efficacy	6.43	.81
Instructional Strategies	6.55	.91
Classroom Management	6.59	.87
Student Engagement	6.14	.83

TABLE 4

Mean and standard deviation of teachers' self efficacy and the respective sub-dimensions

Types of teachers	n	Overall Teacher Efficacy		Instructional Strategies		Classroom Management		Student Engagement	
		Mean	SD	Mean	SD	Mean	SD	Mean	SD
Home Economic	73	6.51	.76	6.18	.78	6.71	.81	6.63	.83
Moral	72	6.33	.86	6.03	.84	6.52	1.0	6.43	.94
Health	93	6.49	.84	6.17	.90	6.60	.84	6.70	.97
Civic	89	6.21	.77	5.94	.80	6.36	.80	6.33	.87
Islamic	92	6.58	.81	6.35	.80	6.60	.87	6.65	.90

(2010), in their studies revealed that most teachers have a better understanding of the efficacy of their actions in the classroom and their abilities to influence the learning process of their students compared to their confidence in helping students value their learning.

The main reason for Islamic education teachers scoring the highest and Civic and Citizenship education teachers scoring the lowest in all three sub dimensions may be the teachers' education backgrounds. As shown in Table 2, 100% of Islamic education teachers teach according to their subject option, and most of them indicate that Islamic education is their major subject.

On the contrary, 97.8% of Civic and Citizenship education teachers are non

option teachers. In addition, 92.1% of them teach this subject as their minor subject. These findings indicate that there is a mismatch between the teachers' options and the subjects taught. According to Wu and Chang (2006) and Yilmaz and Cavas (2008), teacher education training programs play a significant role in fostering teacher efficacy. The number of courses taken related to their subject matters during the education programs will influence teachers' self-efficacy. Even though the Curriculum Development Centre provides training in family life education, it does not involve all teachers. This may result in insufficiency of in-depth content knowledge and conceptual understanding of family life teaching issues, which, in turn, may affect the teachers'

confidence and ability to teach family life.

Another reason may be the experiences that teachers have had. The study shows that the majority of Civic and Citizenship education teachers have less than five years of experience in teaching family life education; some of them have no experience in teaching family life compared to Islamic teachers. Wilson and Tan (2004), in their study on the efficacy of elementary school social studies teachers, found that teachers with more than 20 years of teaching experience have greater self-efficacy than those with less than 20 years of teaching experience. Age is a factor closely linked to years of experience (Yeo, Ang, Chong, Huan, & Quek, 2008). With more years of experience, teachers can see, experience, and handle different situations and critically reflect on those situations (Hui & Cheung, 2004). This can help them grow in confidence and handle similar situations better or in a more mature way the next time they come across them.

On the basis of the results of the study, teacher education training needs to evaluate efficacy levels of the teachers' teaching process and find ways to enhance their efficacy beliefs regarding family life education. Because of the vital role that teachers play in educating the younger generation regarding family life, teacher education training needs to provide ongoing support for teachers, especially Civic and Citizenship education teachers, so that they can develop and maintain strong self-efficacy in teaching family life. In addition, professional development programs should

target not only English, Science, and Math teachers but also family life education teachers to strengthen their knowledge and pedagogical skills on issues related to family life.

CONCLUSION

Teacher efficacy is an important issue in the field of education, especially when society wants to increase its quality of education and the future of its people's values and morals. By examining the self-efficacy of secondary school family life education teachers, this study concludes that these teachers perceive themselves as having high efficacy in teaching family life. To successfully implement family life education programs, teachers' self-efficacy needs to be given true attention. This is where teachers' beliefs regarding their ability to teach family life and improve students' moral behaviors and family values need to be enhanced.

This study concludes with a list of recommendations for teachers to foster their self-efficacy in teaching family life:

- i. Have more vicarious experiences, such as watching and observing experienced teachers teach.
- ii. Establish peer relationships for effective guidance and support from experienced teachers.
- iii. Create more opportunities for self-reflective, context-based, in-class teaching practice as a mean to gain mastery or enactive experience.
- iv. Analyze the complex task of teaching, studying the demanding task in detail,

holistically as well as in separate individual segments, for better understanding and application.

REFERENCES

- Abd. Rahim, B., Mohd. Majid, K., Rashid, J., & Novel, L. (2008). Teaching efficacy of University Putra Malaysia trainee teachers in teaching Malay language as a first language. *Pertanika Journal of Social Sciences and Humanities*, 16(1), 1-14.
- Allinder, R. M. (1995). An examination of the relationship between teacher efficacy and curriculum-based measurement. *Remedial and Special Education*, 99(16).
- Angelle, P. S. (2002). Mentoring the beginning teacher: providing assistance in differentially effective middle schools. *The High School Journal*, 86(1).
- Bandura, A. (1995). *Self-efficacy In Changing Societies*. New York: Cambridge University Press.
- Cakiroglu, J., Cakiroglu, E., & Boone, W. J. (2005). Pre-Service Teacher Self-Efficacy Beliefs Regarding Science Teaching: A Comparison of Pre-Service Teachers in Turkey and the USA. *Science Educator*, 14(1), 31-39.
- Cheung, H. Y. (2008). Teaching efficacy: A comparative study of Hong Kong and Shanghai Primary in-service teachers. *The Australia Educational Researcher*, 35(1).
- Dana, M. (2002). *Theory and rationale*. Retrieved on June 9, 2011, daripada Prepare tomorrow's parents: Promoting and facilitating parenting education for children and teens: <http://www.preparetomorrowparents.org/theory.html>
- Hoy, A. W. (2004). *What do teachers need to know about self-efficacy?*. Paper presented at the Annual Meeting of the American Educational Research Association. San Diego, CA.
- Hui, S., & Cheung, H. (2004). How does learning happen for people participating in adventure training? *Asia Pacific Education Review*, 5(1), 76-87.
- IPPF (2011). Family Life Education: A guide for youth organizations. *The world health organizations' information series on school health document 8: Family life, reproductive health and population education*. London: International Planned Parenthood Federation.
- Kaufman, S., & Sawyer, B. E. (2004). Primary-grade teachers' self-efficacy beliefs, attitudes toward teaching, and discipline and teaching practice priorities in relation to the responsive classroom approach. *The Elementary School Journal*, 104(4).
- Kotaman, H. (2010). Turkish early childhood educators' sense of teacher efficacy. *Electronic Journal of Research in Educational Psychology*, 8(2), 603-616.
- Margolis, H., & McCabe, P. P. (2006). Improving self-efficacy and motivation: What to do, what to say. *Intervention in School and Clinic*, 41, 218-227.
- Pusat Perkembangan Kurikulum (2005). *Buku panduan pengajaran dan pembelajaran nilai merentas kurikulum*. Kuala Lumpur: Kementerian Pelajaran Malaysia.
- Rahmah, M. (2005). *Factors associated with sense of efficacy among first year teachers in Sarawak*. (Unpublished doctoral dissertation). Universiti Putra Malaysia.
- Shidler, L. (2009). The impact of time spent coaching for teacher efficacy on student achievement. *Early Childhood Education*, 36, 453-460.
- Siegle, D., & McCoach, D. B. (2007). Increasing student Mathematics self-efficacy through teacher training. *Journal of Advanced Academics*, 18, 278-312.

- Siti Safariah, A. O. (2009). *Hubungan amalan pengajaran dan pembelajaran dengan pencapaian pelajar di sekolah menengah agama kerajaan negeri Selangor, Malaysia*. (Unpublished Doctoral Dissertation). Universiti Putra Malaysia.
- Teng, L. K. (2006). *Pengaruh Faktor Terpilih Terhadap Efikasi-Kendiri Guru Sekolah Menengah Di Negeri Sarawak*. (Doctoral dissertation). Universiti Putra Malaysia.
- Tschannen-Moran, M., & Woolfolk Hoy, A. (2001). Teacher Efficacy: Capturing an Elusive Construct. *Teaching and Teacher Education*, 17(7), 783-805.
- Tschannen-Moran, M., & Woolfolk Hoy, A. (2007). The differential antecedents of self-efficacy beliefs of novice and experienced teachers. *Teaching and Teacher Education*, 23, 944-956.
- Wilson, P., & Tan, G. (2004). Singapore teachers' personal and general efficacy for teaching primary social studies. *International Research in Geographical and Environmental Education*, 13, 209-222.
- Wolters, C. A., & Daugherty, S. G. (2007). Goal structures and teachers' sense of efficacy: Their relation and association to teaching experience and academic level. *Journal of Educational Psychology*, 99(1), 181-193.
- Yeo, L. S., Ang, R. P., Chong, W. H., Huan, V. S., & Quek, C. L. (2008). Teacher efficacy in the context of teaching low achieving students. *Curriculum Psychology*, 27, 192-204.

Investigating Thomas Hardy's Reaction to Victorian Religious Forces through Reading *Tess of the D'Urbervilles* and *Jude the Obscure*

Faezeh Sivandipour and Rosli Talif*

Department of English, Faculty of Modern Languages and Communication, Universiti Putra Malaysia, 43400 UPM Serdang, Selangor, Malaysia

ABSTRACT

The Victorian era during the nineteenth century was marked by the Church of England and was greatly associated with “Victorian values,” strict rules, formal manners, rigidly defined roles and highly moralistic standards of behaviour. Considering the main religious thoughts of that period, this study examines the basic religious notions of the time which had an effect on Thomas Hardy and provoked him to question the existing religious and social forces of the time through *Tess of the D'Urbervilles* (1891) and *Jude the Obscure* (1895). Due to his many bitter and tragic stories, most readers consider him a pessimist writer—a description that he himself does not agree. Rather, Hardy considers himself a ‘meliorist’; therefore, he cannot accept being a pessimist. It is significant to note the religious clues in his two mentioned novels, which help the reader to see a reflection of his inner beliefs and his religious outlook on his characters as well. This article, based for the most part on several quotations of the two novels, attempts to extrapolate religious and social problems of the Victorian age and the way Thomas Hardy responds to the so-called Victorian notions through considering his emphasis on repeating the consequences of these forces in the selected novels.

Keywords: Thomas Hardy, Christianity, Victorian era, Evangelicalism, *Tess of the D'Urbervilles*, *Jude the Obscure*

ARTICLE INFO

Article history:

Received: 19 November 2012

Accepted: 7 March 2013

E-mail addresses:

fa.sivandipour@gmail.com (Faezeh Sivandipour),

rtalif@upm.edu.my (Rosli Talif)

* Corresponding author

INTRODUCTION

The Victorian era, broadly designated as the distinctive period during which Queen Victoria reigned from 1837-1901, is also known as the ‘Age of Transition’—change from medieval tradition of social and

religious hierarchy to scientific revolution. Besides religious and scientific discoveries, many social acts and transformations occurred during this time which inevitably affected the theme of many novels and literary works. There were also various political and religious notions and movements that altered the outlook of the people at that age. The most important religious movement of the time was the 'Evangelical Movement.' Pierard (2006) defines Evangelicalism as a Protestant Christian movement which began in Great Britain in the 1730s, and it was a belief that emphasised the need for personal conversion or, in a way, being born again (p.15). Evangelicals were social reformists and the term 'Evangelical' had its etymological roots in the Greek word for 'gospel' or 'good news,' so in this sense, to be Evangelical would mean to be a believer in the gospel—that is the message of Jesus Christ (p.17). As Evans (2001) explains, Evangelicalism provided one central influence on the definition of home and family. It emphasised the creation of a new life-style, a new ethic, and provided the framework for the emergence of the Victorian bourgeoisie (p.1). It is believed that Evangelical morality was probably the single most widespread influence in Victorian England and Evangelicals were loyal members of the Church of England, who believed in their reform. Quinlan (1941) states that the evangelicals' other attempt was to change national morality to redefine the available cultural norms and during that time the attack on morality was a highly organized movement (p.15).

Additionally, Evans subscribes to the Evangelical concern with national morality, mainly the belief that religion should be a daily rule of life rather than a question of doctrinal purity. As Evans declares, they emphasised the importance of a well-ordered daily routine and their irresistible sense of sin required the formulation of rules for daily life (p.2). In this case, Wilberforce (1797) gives the clearest statements of Evangelical views and states that: "Christianity is a state into which we are not born, but into which we must be translated; a nature which we do not inherit, but into which we are to be created anew" (p.298).

Between 1790 and 1820 the Evangelicalism movement was increasingly successful in establishing itself as a part of the dominant culture. Eventually; however, it lost its early purity and could justly be accused of priggishness, conventionality, hypocrisy and conservatism (Evans 3). Also, Evangelicals insist that men and women are not equal and the sexes are naturally distinct, so women should be better educated, beyond just being better wives and mothers (p.22).

In the 1790s, Evangelicalism has been described as 'the religion of the household' and it is clear that the notion of home and family was central to their religious views. Home was one place where attempts could be made to control and limit sin in the world outside. According to Evangelicals, the household was seen as the basis for a proper religious life and morality began at home. The basic split was between the world as hostile and the home as loving.

It was a split that became commonplace in Victorian England and eventually the split between the private and the public spheres became a split between the sexes of an unusually exaggerated kind. This linking of the religious with the domestic was extended to the division between the public and the private area, and was the ideal of the Evangelicals' idea of the home. Home became the sphere of women and the family, and the world outside became the sphere of men. Family prayer became a symbol of the togetherness which was mainly done by mothers (pp.7-9).

As More (1777) states, Evangelicals considered cultural differences as natural differences and according to them, women were naturally more delicate, more fragile, morally weaker, and all this demanded a greater degree of caution, retirement and reserve. According to them, women could act as the moral regenerators of the nation and they occupied the main position in the struggle for reforming and reviving the nation. In their viewpoint, a good woman had recognizable characteristics, which were being modest, unassuming, unaffected and rational. Being 'rational' meant to be not 'sentimental' or having violent feelings. Also to the Evangelicals, it was clear that man was the wiser partner and could guide woman into the appropriate area; therefore, he could introduce to her new ideas (p.5).

Thomas Hardy (1840-1928) was born in such a time within all these mentioned notions and movements. He experienced the Victorian Age that was full of conflicts and contradictions. They were all very important

and significantly influenced his thinking and beliefs. All these notions influenced him in such a way that he tried to reflect all of them in his writings. Many of the Evangelicals' ideals of good woman, social and Christian attitudes can be traced in Thomas Hardy's *Tess of the D'Urbervilles* (1891) and *Jude the Obscure* (1895). Also as in Evangelical life, the right choice in marriage was vital, since the religious household was the basis of Christian practice; therefore, the image of marriage was very central to Evangelicalism and Hardy showed this image in his mentioned novels. In a way, the Victorians treated their women in a distressing manner—even in religion. Their harsh distinction between women and men forced women to be well and to do well all the time. It gives the impression that it was women's duty to be well and to behave well and this was the main sexual discrimination of that time. As Gisborne (1801) suggests, within marriage it was clear that the wife was subordinate to her husband and it was quite essential for her to be faithful and obedient (p.41).

Thomas Hardy as a young man had an important Evangelical phase that left a deep impression on his thoughts. Despite the claim by Henry Bastow (who was an enthusiastic Baptist) that Hardy was an Evangelical, scholars have generally dismissed his remarks largely on the basis of the autobiography (Williams, pp.70-71). Also according to Dalziel (2006), Hardy had lifelong connections to the orthodox Christianity he was soon to abandon. His family's associations with the established

church, his lifelong love of church music and the language of the Bible and the Book of Common Prayer, his continued attendance of religious services, his poetry's occasional expression longing for belief, his conviction that the Church was, and should remain, the social, ethical, and educational centre of a community, all support his religious connections. However, despite all these lifelong connections, Hardy repeatedly expressed his certainty that "the 'Cause of Things' must be unconscious" (pp.12-13). Considering all the mentioned Victorian notions and the way critics define Hardy's religious views, this article investigates the many ways that Hardy responds to the existing Victorian religious and social forces in his mentioned novels, in order to make the readers aware of the problematic situation of his time.

DISCUSSION

Hardy's biography clearly shows that he is very familiar with Christianity and in stating his society's problems and its attitudes toward women he is merely reacting to Victorian social and religious forces. In describing the situations of different people from different social classes of his time, in his selected novels, he is in sense of paving the way for a change in some of the existing forces of his time. Hardy describes the situations of different people from different social classes of his time and arouses the readers' pity in order to relieve himself of the burden of the problematic Victorian society. The dominant situation of the Victorian era disappoints him and he

seeks refuge in his novels, but even there he cannot state his ideas freely and his novels face lots of harsh criticism. Despite all this, he attempts to express himself and his ideas through his characters. For this, he uses some Victorian social and religious matters to show his reaction to the established Victorian Christianity as well as the Victorian social problems. Through such analysis, this paper tries to unveil Hardy's direct or indirect religious reactions to Victorians' society.

To start with *Tess*, Hardy makes use of his 'meliorist' ideas and tries to criticise as many social and religious matters and beliefs as possible to emphasise that the existing Victorian norms are not fair and if people want to have a better life, they all should struggle because there is no 'guardian angel' to save them as they may think. At the end of the first phase, when Tess is raped by Alec, Hardy writes: "But, might some say, where was Tess's guardian angel? Where was the providence of her simple faith? Perhaps, like that other god of whom the ironical Tishbite spoke, he was talking, or he was pursuing, or he was in a journey, or he was sleeping and not to be awaked" (p.91). Here Hardy tries to talk to his readers in an ironic way, as if in the middle of the story he wishes to state his ideas of how much this world is shallow and absurd. He wants to mock the whole system of religious beliefs, that there is always a great power, who controls their destiny and moderates the cruelty upon their lives. In a way, Hardy aims to prove his own state of being a 'meliorist', that the world can be better, just if people try. So according

to him, it is not enough to put everything in God's control and wish that he fixes them all. All the people have important roles in each other's lives so they themselves have to try to make good situations for each other.

On her way home, Tess visits a man who writes religious slogans on the wall, "THY, DAMNATION, SLUMBERTH, NOT". As Hardy describes, these words seem to shout themselves out, "Some people might have cried 'Alas, poor Theology!' at the hideous defacement-the last grotesque phase of a creed which had served mankind well in its time. But the words entered Tess with accusatory horror" (p.101). These words are crushing and killing for Tess and they impress her. It is significant that these words, which are meant to prick the conscious of the guilty ones, impress the innocent like Tess. This is Hardy's way of implying that religion is not supposed to threaten the innocent, but to pave the way for all people to find their ways through life, to have salvation and not something which is considered as crushing, fearful and threatening.

This particular page of the novel is religious and symbolic. At first, the presence of this man with his harsh sentences gains the reader's attention. Secondly, Hardy uses 'poor theology' to say that the time for Christianity is finished. His sentences here suggest that Christianity has become useless in his era, because according to him while it saved people in its time, now it cannot. On the other hand, Tess is a lonely girl who feels lonelier from reading these words. She thinks this man knows everything about her,

which prompts her to ask: "Suppose your sin was not of your own seeking?" His answer is: "I leave their application to the hearts of the people who read 'em." In a way Hardy tries to say that even preachers do not try to preach and guide people completely. Whenever they feel that they are not able to answer people's questions, they put them in another dilemma instead of guiding them. Also, here Hardy seems to suggest that Christianity of his time has come to be equated to mere slogans. These slogans are written or spoken and you have to interpret them yourselves. It is not something helpful that can pave the way for people's better future. It depends on how you interpret them and it is therefore something which is totally subjective and personal.

Tess feels sinful because Alec has raped her, so she wants to purify herself and feels the need to go to church on Sunday mornings: "She liked to hear the chanting ... That innate love of melody, which she had inherited from her ballad-singing mother, gave her the simplest music a power over her which could well-nigh drag her heart out of her bosom at times" (p.106). Here, Hardy uses the word 'inherited' to question what kind of religion can be an inherited one. He wants to signify that Tess, just like many people, becomes accustomed to religious rites. Tess feels better in the church because of her childhood memories and because she is familiar with all these ballads and melodies rather than a mere love of going to church. Whatever Tess' intention is of coming to church, for some moments she really feels good and calm, but she begins

to feel uncomfortable when she realises the presence of others around her and feels like hiding herself, as Hardy describes it: “She knew what their whispers were about, grew sick at heart, and felt that she could come to church no more” (p.107). This shows that even in church she feels lonely and inferior to others. Then Hardy describes the parishioners coming to church pretending to pray when they do not really do so. All these lines are significant and show Hardy’s reactions towards people’s behaviour and the preachers’ as well.

Some pages later, he writes: “One could feel that a saner religion had never prevailed under the sky” (p.109). Here Hardy refers to religion and mentions that there never has been a sensible and reasonable religion under this sky. Hardy seems to hint of his belief that if there were, everything would be better than this. In all ways, it is obvious that Hardy tries to show and present his own feelings and religious attitudes through Tess. Whenever Tess wanders she praises Nature and thinks about God, as one day Tess is in her way to the dairy and she searches for a song in her mind to sing then she chants, “She suddenly stopped and murmured: ‘But perhaps I don’t quite know the Lord as yet’” (p.134). Tess feels that she has a bad life just because she is not a perfect, pure and religious worshipper to God as she must be. On the other hand, Hardy wants to show how much Tess is close to God, because most of the time, deep inside she praises and talks to God. In a way, Hardy wishes to show his reaction to the religious forces and make the point that it is not important to

just do the rituals and religious ceremonies, but more important is to be with God inside and be a grateful creature as Tess is. In many parts of the novel, Hardy signifies this matter that faith and Christianity in his time are not alive anymore. So, in this case, he wants to prove that now it is people’s turn to make a change and pave the way for their better lives and happiness.

As an example we can refer to the time when Tess is in the dairy and two men are telling a story of past times. She hears one of them saying: “It’s a curious story; it carries us back to mediaeval times, when faith was a living thing!” (p.143). Here, and in several other parts of the story, Hardy compares the faith of his time to that of the past and hints at it being less strong than before. Again when Angel is reading some books on philosophy, his father says:

“How can you think of reading it?”

“How can I? Why – it is a system of philosophy. There is no more moral, or even religious, work published.”

“Yes – moral enough; I don’t deny that. But religious! – and for you, who intend to be a minister of the Gospel!” (p.148).

Hardy highlights this conversation between Angel and his father to reflect his own ideas and says how religious people of the time narrowly limit their knowledge by reading just religious books. Angel’s father thinks that if Angel does not want to become a minister, there is no need for him to go to university. Totally, the

belief appears to be that their life has one target – to be knowledgeable in religion and to be physically present in church. As the quotations in this part illustrate, in *Tess*, Hardy tries to bring and repeat many social and religious problems that cause people's misery instead of their happiness. Therefore, it becomes clear to the reader that Hardy wants to show his reactions to these religious and social matters to pave the way for a change for betterment by awaking the readers' minds through these reactions.

Another important aspect that Hardy emphasises in *Tess* and *Jude* is the question of divorce in some branches of Christianity. Tess' life is ruined because Angel thought religiously she is Alec's wife, also Jude and Sue both face problem in their relationship because they are not divorced from their respective spouses. It is to show how much this is a troublesome matter. In an indirect way, Hardy shows how such a situation leads to tragic ends for the parties involved. Is Hardy asking the question: 'If a person marries the wrong one for the first time, why must he or she be under oath to her or him for the rest of his or her life?' In a way Hardy wants to change the readers' mind about the existing notions, in order to make life better and easier. Hardy wants to force the reader to think about these religious facts by repeating them in his selected novels to pave the way for a solution; also, he aims to criticise some of the existing rules and regulations of his time. Hardy wants to suggest that many of these rules and forces are not helpful and they just act in opposite. This idea is seen in this part of the novel when Jude becomes

more and more interested in Sue, she tells him that she wants to go to London to work. Jude suggests that she should work under Mr. Phillotson's supervision and try to be a teacher instead of going to London. In that case he would not be alone and she accepts: "It was part of his [Mr. Pillotson's] duty to give her private lessons in the evening, and some article in the Code made it necessary that a respectable, elderly woman should be present at these lessons when the teacher and the taught were of different sexes" (p.126). This situation is ironic here, for although the rules and regulations of the time were very strict and despite the presence of an elderly woman in Mr. Phillotson's classes, Phillotson eventually falls in love with Sue. Thus, Hardy wants to point out that none of the strict rules and regulations of the era are successful and they end up producing the opposite of what is desired. Even in strict Victorian time, it is obvious that people will always be tempted to do what they should not. Later, when Jude finds out that Sue and Richard are going to marry, he invites Sue to the cathedral for a talk, but Sue says: "Cathedral? Yes. Though I think I'd rather sit in the railway station," she answered, a remnant of vexation still in her voice. "That's the centre of the town life now. The Cathedral has had its day!" (p.160) . More and more, Hardy tries to suggest that sticking to religion and church is not enough. In a way, he wants to suggest that one must not close one's eyes and forget about all the scientific and social progress that is happening just because they may appear to be against church and religious

attitudes and he appears to advocate an open mind that is prepared to accept change for the better.

Several parts through the story Hardy wants to convey that it is not important to just follow the rituals and ceremonies. In a way, he wants to suggest that it is more religious to be inside with God and try for the betterment of the world and all the people, not just doing the rituals and reading the Bible out of fear of God. Most of the characters in *Tess* and *Jude* just try to go to church and do the ceremonies to mask their lack of faith, but in reality they do not help each other and rather with their interferences in each other's lives make many problems for their fellow creatures. That is why Jude and Sue fail very badly and cannot continue as they wish. Also, when Jude reveals his love for Sue, she becomes nervous because of Arabella and says:

"How strange of you to stay apart from her like this!" said Sue, her trembling lip and lumpy throat belying her irony. 'You, such a religious man. How will the demigods in your Pantheon – I mean those legendary persons you call Saints – intercede for you after this? Now if I had done such a thing it would have been different, and not remarkable, for I at least don't regard marriage as a Sacrament. Your theories are not so advanced as your practice!" (p.199).

Again here it is signified that whatever people bear in their mind as religious

theories cannot be helpful for their life, unless they really believe in it and accept it. Through *Jude* Hardy shows that most of the people just pretend to be religious but in reality they just act the opposite. Hardy places the emphasis on this matter and suggests that even people like Jude, who studied a lot about religion, does not practice what he preaches.

In another part, when Jude's aunt dies, Sue goes there for her funeral. There, Sue explains how much she is disturbed and what marriage means to her:

"... I am certain one ought to be allowed to undo what one has done so ignorantly! I daresay it happens to lots of women; only they submit, and I kick. ... When people of a later age look back upon the barbarous customs and superstitions of the times that we have the unhappiness to live in, what will they say!" (p.256).

Sue is in trouble with the marriage rules of their religious society. The fact that a married couple cannot divorce is a killing fact for them. Although this matter is very troubling for many people in her time, Sue mentions that most of them tolerate it. In a way Hardy wants to suggest why a religious fact must be something killing and troubling for its followers. After all, it is expected that religion, as God's way, should be something that guide people and lead them to the best.

Another important social reaction that Hardy highlights in *Jude* is people's interference in each other's lives. This

problem ruins the lives of both Jude and Sue. As an example, when Little Time (Jude's son) goes to school, other children scorn him because his parents are not legally married. When Jude and Sue hear it, they become really sad. Thus, they go to London for a while and after that when they return, they announce themselves as a married couple. This just makes the situation worse and: "Nobody molested them, it is true; but an oppressive atmosphere began to encircle their souls, particularly after their excursion to the Show, as if that visit had brought some evil influence to bear on them" (p.355). Soon after, people shy away from doing business with Jude and gradually he becomes poor. This is an indication of how social controls can negatively impact people's lives. Even when Jude finds a job in the Church to paint the Ten Commandments with Sue, they again see that Little Time comes and cries because of his classmates' insults. Also, one day during their work two men are talking in the Church and they intentionally tell a story of two people who many years ago painted the church and because they were sinful, nobody attended that church for many years. When they go out, Sue cries and says: "I can't *bear* that they, and everybody, should think people wicked because they may have chosen to live their own way! It is really these opinions that make the best intentioned people reckless, and actually become immoral!" (p.360). Soon afterwards, the contractor goes to the church, talks to Jude and asks them to leave.

These lines clearly suggest the idea that Hardy wants to highlight the religious biases

of that time just like prejudiced notions can ruin people's lives. The orthodox characters in the story cannot pave the way for a better life for poor people like Jude and his family, but instead force them to death with their bias. While the basic tenets of Christianity are friendship, helpfulness, brotherhood and forgiveness, it seems that these characters have never heard any of them and just try to stick to the Christian ceremonies. When Jude sees people's reactions to him and his family, he cannot tolerate the situation anymore and says: "People don't understand us, I am glad we have decided to go." Then Sue answers: "The question is, where to?" (p.363). As the society cannot accept their unreligious relationship, they eventually lose everything. One by one, Jude sells whatever he inherited from his aunt and they become very poor. Finally, Jude concludes that they have to go somewhere else. The troublesome fact of people's interference continues to the end of the story and through this it seems that Hardy wants to ask which way is good: to let people be themselves, make decisions for their lives and be happy or to ruin people's lives because they do not act according to conventions and religious rituals?

When Sue tells Jude about her conversation with Abbey and the fact that Abbey's husband is dead, Jude decides to go with his family to Christminster. When they arrive, they rent a room and Jude goes out to walk, then the landlady talks to Sue: "Are you really a married woman?" (p.394), at first Sue hesitates, then she tells the truth and the landlady goes out and talks

about these matters to her husband, but her husband becomes very angry and shouts. So, the landlady comes to Sue and tells her that she would be very glad if they leave the next day. Sue tells the truth and her honesty becomes her biggest problem. Throughout the whole story the reader can see that Sue and Jude are both honest and they are punished because of their true purity and honesty. This is because their society forces people to pretend to be religious while true purity and moral integrity matter not.

All these social reactions worsen the situation for Jude and his family. When Little Time feels Sue's sorrow, he gets really sad and asks: "I ought not to be born, ought I?" (p.396). Sue talks to him for hours about their problems but Little Time is not assured. The day after when Sue returns, she finds that Little Time has killed the two babies and hanged himself. She finds a letter in his hand writing on the ground, which says: "Done because we were too menny" (p.401).

Jude and Sue's whole life turns into a real mess, just because their so-called religious society cannot accept their non-religious union. The people around Jude's family ruin several lives just because of their prejudice. These people act irreligiously and respect all the ceremonies to pretend that they are religious. That is why the above facts are considered as religious forces in Hardy's time and he tries to react to them in *Tess* and *Jude*.

CONCLUSION

Hardy cannot accept the existence of any such thing as Providence, that is, a force

which makes everything in the world work towards good, which is a favourite Victorian belief. In his later novels, *Tess of the D'Urbervilles* and *Jude the Obscure*, his message is clear—that there is no supernatural force which looks after the innocent. Especially in *Tess*, he highlights this matter in different parts of the story, leading several critics to consider his works as examples of 'pessimism,' which he does not accept. According to Williams, this is because Hardy considers himself rather a 'meliorist', that is, one who believes that the world can be made better only if people try and make it so (p.74).

Altogether, it can be concluded that it is not just one notion or religious attitude that affects Hardy's manner, but rather a series of movements and ideas that shape his thoughts and reactions. These influences are often reflected in his mentioned novels in various ways and they include Darwinism, along with the Evangelicals' movement, and Hardy's own personal belief in some 'Unconscious Will' that move him towards being a 'meliorist.'

Hardy's portrayal of Tess, Sue and Jude is merely to state his personal reactions to the values and attitudes toward religion and social correctness of his time. He highlights peoples' religious biases that make them blind. In doing so, he tries to show the real norms of Christianity, to suggest what features and ideas are good to have and which ones are not. He does his best to suggest that religion is not something just for pretention or ceremonies, but should be about the true purity and goodness of people

that guides them through their lives. Many times in these novels he suggests that it is not enough to just follow religious rituals to have a good life. To Hardy, what is more important is that people should try to pave the way for the betterment of their lives with their kindness and helpfulness towards each other. Thus, in these novels, he tries to reconcile all the ideologies with all the new findings of his age to suggest new notions about God, life and fate.

Hardy is seen as constantly seeking answers through reactions to the religious forces and the religious pretensions of his time. At the same time, he doubts the sincerity and faith of both theologians and the people and thinks they are doing nothing more than merely using conventions and ceremonies to mask their lack of faith. This paper highlights various examples in these novels to justify this particular view point. Through repeating the question of divorce in these novels, Hardy is protesting against the social problems of his time. The other social matter which is very dominant in Hardy's *Jude* is the religious hypocrisy of the people, pretending to be religious and placing great importance on ceremonies while not possessing true faith and belief. Hardy also draws attention to the fact that in Victorian society, people seem to interfere with the lives of others and at the same time close their mind to new ideas and anything that seems to contradict their traditional religious thinking. Hardy does his best to suggest that religion should be based on the self purity and the good feeling inside which guides people through their lives. He

even tries to suggest that it is not enough to just follow religious rituals to have a good life. More important is to try to pave the way for better lives through kindness and helpfulness towards each other. It is the sense of being a 'meliorist' in Hardy that implies all these.

REFERENCES

- Dalziel, P. (2006). Strange Sermon: The Gospel According to Thomas Hardy. *Times Literary Supplement*, 17 March, pp.12-13.
- Evans, M. (2001). *Feminism: Critical Concepts in Literary and Cultural Studies*. (2nd vol). London: Routledge.
- Gisborne, T. (1801). *Duties of the Female Sex*. London: Cadell and Davies.
- Hardy, Thomas. (1994). *Jude the Obscure*. London: Penguin.
- Hardy, Thomas (1994). *Tess of the D'Urbervilles*. London: Penguin.
- More, H. (1777). *Essays Principally Designed for Young Ladies*. London: Seeley and Burnside.
- Pierard, R. V. (2006). *The Unequal Yoke: Evangelical Christianity and Political Conservatism*. Eugene: Wipf.
- Quinlan, M. (1941). *Victorian Prelude: A History of English Manners 1700-1830*. London: Colombia University Press.
- Wilberforce, W. (1797). *A Practical View of the Prevailing Religious System of Professed Christians in the Higher and Middle Classes in this Country Contrasted with Real Christianity*. London: Cadell and Davies.
- Williams, M. (1993). *A Preface to Hardy*. 2nd ed. London: Longman.



A Stylistic Analysis of News English-Arabic Translation

Kais Amir Kadhim

*English Department, Faculty of Language and Linguistics, University of Malaya,
50603 Kuala Lumpur, Malaysia*

ABSTRACT

Leech and Short (1981, p.74) argues that every analysis of style is an attempt to find the artistic principles behind an author's choice of language. Hence, this article focuses on the stylistic that exist in English-Arabic translation texts of the British Broadcasting Corporation's (BBC) political news. It attempts to find the nature of the stylistic changes as proposed by Vinay and Darbelnet (1995) and also to show how the differences in the order of sentence constituents and the points of grammars of the Source Texts (ST) and Target Texts (TT) contribute to the stylistic and the semantic changes. This paper deals with the sequences of the sentence constituents, some elements of grammar such as tenses, prepositions and adverbs, and the semantic changes that have consequently taken place in the Arabic translation. The paper makes use of the stylistic ideas of Ghazala (1995) as well as X' Theory by Culicover (1997) to capture the syntactic changes. The analysis of the data shows the following:

- (a) The semantic changes are attributable to the differences on points of grammar (tenses, prepositions and adverbs) the differences in the weltanschauung (world-view) of the speakers of the ST and the TT arising from different cultural emphasis and differences in some socio-linguistics elements; and
- (b) The stylistic changes are essentially arising from differing language structures.

Keywords: Grammar, syntax, semantics, changes, style and translation

ARTICLE INFO

Article history:

Received: 26 November 2012

Accepted: 21 March 2013

E-mail address:

kaisamir2009@yahoo.com (Kais Amir Kadhim)

* Corresponding author

INTRODUCTION

Some scholars may find the terms literary stylistics and linguistics stylistics confusing due to their somehow similarities. But any such study that leans heavily on external correlates with none or just a smattering of

attention to the 'rules guiding the operation of the language' can be regarded as literary stylistics. Unlike linguistics stylistics which relies heavily on the rules of language in the explication of a literary text, we call it here linguistics stylistics, Nnadi (2010, p.23). According to Enkvist (1973, p.92), linguistics stylistics is referred as stylolinguistics. This paper is a stylolinguistics study that intends to explore the translation problems and the solutions on an extended dimension of linguistics stylistics. The analysis includes the realm of styles. The study analyzes the translation of English political news-texts (source text =ST) into Arabic news-texts (target text = TT). It pays more attention to style as well as looking at the changes of the whole message. Mainly, it is a comparative study that examines the linguistics stylistic differences between the English ST and their corresponding Arabic texts. However, linguistics stylistic and message analysis have yet to receive due attention and the specific study of style in the translation of English News texts into Arabic is even less common. Underpinning the above is the assumption that translating a language into another language creates many stylistic problems. These problems may affect the message of the source texts through the processes of translation. In addition, the cultural and sociolinguistic differences between both languages (source and target languages) play a big role in producing a good translation output. All these differences may compel the translator to make some changes in style when translating one

language to another. These changes may in turn affect the messages, contributing to a disparity in some cases between the content of the ST and the content of the TT.

A linguistics stylistic approach to translation involves assessing the style of the source text and its effects, including the inferences it permits (Gutt, 2000, pp.24-25), the gaps it manifests, thorough ambiguity, compression, or incompleteness. These allow the reader to 'climb aboard' the text (Iser, 1974, p.275) and become involved in it. The stylistics in England has been applied largely to literary texts (Leech & Short 2007, p.10). It is here that I find the most interesting interactions with translation. One of the main tasks of stylistics in literary translation is to consider the kind of dynamic, creative reading that many literary translation scholars, especially those influenced by the poststructuralist view of the reader as 'producer of the text', consider to be essential (cf.Scott, 2000, p.183-185) and to assess the facilitation of the linguistic stylistic detail of the text. However, beyond this, a linguistics stylistic approach needs to explain how 'reading for translation' (based on Slobin's 'thinking for translation' 2003, p.164; see Boase-Beier, 2006, p.24) takes place. Specifically, it needs to account for the close reading which translation scholars such as Bell (1998, p.186) deem to be a prerequisite for translation.

According to Wales (2001, p.373) and (Stockwell, 2002, pp.1-8), "Style refers to the perceived manner of expression in writing or speaking". In this case, the style

of writing can be radical, tragic, comic, and so on, depending on the ultimate intentions of the writer. Based on the definition, style is glimpsed as the way writer expresses his/her feelings to the outer world. Literature is not written in a vacuum, there must be a message the writer has in mind to convey, the way he/she uses language to convey his/her message to the world is referred to as the style of the writer. To strengthen this definition, Malic (1971) as cited in Lawal (1997, p.34) says, "the style of an author has a consistency due to the habitual nature of the writing process and this consistency can be determined, measured and used to determine consanguinity between an unknown and a set of authenticate text". Furthermore, Ibrahim (2000, p.57) says, "style is the verbal coating or dressing of one's thoughts, ideas and feelings in a method that is peculiar or unique to a particular author". The perception of authors differs; therefore, they tend to use different style in their works. As mentioned earlier, we have been able to showcase the true nature of styles and we have come to understand that style is the way authors convey their messages through the use of language which may differ and may also give recognition to an author in terms of his/her style. Crystal (1992, p.34) opines that "stylistics is the study of aesthetic use of language in all linguistic domains". In this definition, linguistics stylistics is showcased as the survey of the beauty in the use of language in all the scopes of linguistics. Contrary to Crystal's "all linguistic domain",

Short (1996, p.1) asserts that "stylistics is an approach to the analysis of (literary) text using linguistic descriptions". Short sees stylistics as the scrutiny of fictitious text in accordance with linguistic guidelines; he limits the scopes of stylistics to literary text neglecting the non-literary aspect of it. Malmjear (1991, p.438) in his contribution sees stylistics as "the style in spoken and written text". Malmjear's contribution agrees with Crystal's by extending the scope of stylistics beyond the literary text. He sees stylistics as the surveys of language used in oral and written text Stylistics studies do not only involve literary, but also non-literary texts. Haynes (1989, p.135) mentions some kind of texts that can be studied and analyzed in stylistics that include conversational narratives, recipes, geometrical - theorem, songs, short stories, maps, children stories and script. In the words of Chapman; (1983, p.135), "Stylistics studies the language adopted to meet peculiarities of situations, attitudes and relationships in specific linguistic acts". Chapman is of the opinion that stylistics deals with different dimensions in which a language can be used to meet relation in a certain discourse. Furthermore, Widdowson (1973, p.3) defines stylistics "as the study of literary discourse from linguistic orientation".

THEORETICAL FRAMEWORK

For the purpose of this article, we employ a few ideas from different writers but will use them compositely and interactively.

Ghazala's ideas on Arabic Writing Style (1995)

In Arabic prose, (Ghazala, 1995, p.242) notes that style of short sentences has an important function as he opines that such a style does heighten the tempo of action in a text. It is written in the form of a story apart from the fact that such a style accelerates events and creates suspense. He adds that it is the only type of style which reflects a function of acceleration that can be sensed by reading the text aloud and quickly. Hence, he suggests that short sentences be re-echoed in the Arabic translation in order to keep this function (Ghazala, 1995, p.242). Ghazala further remarks that the style of long sentences, in English-Arabic translation, is better to be imitated in Arabic because it has important stylistic functions which are a part of the meaning of the text. He adds that translating an English long sentence into Arabic long sentence might be less problematic than breaking it into short sentences, (Ghazala, 1995, p.245). Ghazala also observes that there is a common mistake of changing the passive sentence into the active counterparts made by some English-Arabic translators who claim that Arabic is an active language, while English is passive, (Ghazala, 1995, p.246). In any case, he adds that this aspect of the Arabic language is by no means settled as both passive and active styles that are used in all types of Arabic texts. As a consequence, both styles, active and passive, have to be reflected in the English-Arabic translations to reflect their important functions in the message (Ghazala, 1995, p.246). In terms

of redundancy and repetition, (Ghazala, 1995, p.252) considers that redundancy is a poor style in translation as it may dispose the meaning of the translation. He adds that such a style is a long and boring way of expressing meaning for example using two, three or more words instead of one word only. The translator's job is to be faithful to the original text. With respect to repetition, (Ghazala, 1995, p.252) opines that '...this style would rather be rendered into Arabic; thus, reflecting the same effect of the original and avoiding the problem of artificial variation which might be hard to accept'. Consequently, as working strategies in our analysis of the Arabic translation of the BBC's news ST, this article takes cognizance of (Ghazala's, 1995, p.12) views of style mentioned in this section which can be summarized as '... the way of expression' in the language of the target readers.

Culicover (1997)

According to (Culicover, 1997, p.134), X'-Theory is a theory of phrase structure; a theory which constitutes a possible phrase in natural language. He adds that within this theory phrase structure affects the hierarchical and left-to-right relationships between syntactic categories. As in Fig.1, he further mentions that every phrase has a head; certain heads take complements. Informally, the relationship between a head and its complements is characterized by the fact that they are sisters. Each c-commands the other and the same node dominate them, (Culicover, 1997, p.135), as illustrated in

the diagram below where V' (verb phrase), V (verb) is the head while NP (noun phrase) is the complement. As shown in below diagram, within this theory, the V', V and NP are all nodes, while the V and NP nodes are sisters. The V' and NP command the other. Some grammatical relationships exist between them.

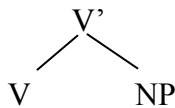

Fig.1: The Structure of A Phrase

He also contends that, “An important principle of X' Theory is that across syntactic categories, complements, specifiers, and adjunct bear the same configurational relationship to the head.” (Culicover, 1997, p.135). Furthermore, “In English...the complement of the head appears adjacent to it and to the right, while the specifier appears to the left” (Culicover, 1997, p. 136). In other languages the sequence may be the reverse. Instead of V-NP as in Fig.1 like in the case of eat cake for English, it may be V-...-NP for Arabic akal -Ali- cake ‘Ali ate cake’. الكعكة. اكله علي الكعكة. ‘ate Ali the cake’. In the theory that he proposes, all phrases have the following structure, called the X'schema, (Culicover, 1997, p.137) as in Fig.2.

According to the X'schema, or X'-theory, a complement is the sister of X(zero), while an adjunct is adjoined to X'. It is an open question whether or not adjuncts can appear at the X(max) level as well. In addition, all branches are binary (i.e.,

dual branching) (Culicover, 1997, p.137). The structure in Fig.2, is universal for all categories and across all languages.

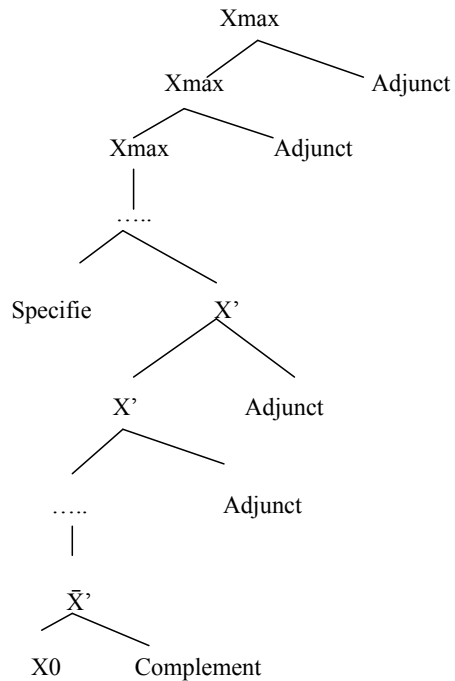

Fig.2: X'schema

VINAY AND DARBELNET (1995)

Vinay and Darbelnet (1995) consider comparative analysis as an essential applied linguistic approach to translation as it is a more direct approach. They focus on the pragmatic stratum which determines the choice of lexical and grammatical devices in the text. They offer two strategies in their approach: direct translation and oblique translation. The former strategy comprises three procedures: (a) borrowing

(b) calque, and (c) literal translation. They employ direct translation whenever a structural and conception parallelism exists between both languages. The latter strategy, oblique translation, has four procedures: (a) transposition, (b) modulation, (c) equivalence, and (d) adaptation which are used whenever grammatical, lexical, structural or conceptual divergences are due to certain stylistic effects in the source text.

The Data

The data presented in this article is collected from the BBC news online from January 2005 to April 2006. One hundred samples are collected as part of our study. However, for the purpose of this article, we have included only eleven political news articles and their corresponding Arabic translation. The BBC's news texts are chosen because they are documents for public consumption whereby many readers are not language experts, mostly laypeople. These newspaper articles are not of general nature instead they are news on political events and happenings. All these articles have been taken from the BBC's website as parallel versions in Arabic can be accessed easily. Finally, each data in the analysis is given the ST, the TT, its Arabic transliteration and the meaning of the structure in issue. The maximal projection in overall the analysis is omitted for shorthand purpose.

Stylistic Changes Due to Borrowing

In this section, we are concerned with the borrowing of Arabic terms in English and how they are retranslated into Arabic

in relation to style. Consider the English example in (1) (a) and its corresponding Arabic translation especially the underlined constituents in (1) (b) and its transliteration in (1) (c):

- (a). ST: ' Bin Laden call falls on deaf ears'

BBC: Monday, 24th April 2006

US intelligence believes the audio tape aired by an Arab TV channel is genuine, making it the fugitive al –Qaeda leader's first message since January. US opposition politicians said it only showed up the Bush administration's failure to capture Bin Laden.

- (b). TT: "بن لا دن " حرب صليبيه غريبه ضد لا سلام

قال اسامة بن لادن زعيم تنظيم القا عدة في تسجيل صوتي منسوب اليه ان تحرك الغرب لعزل الحكومة الفلسطينية " بقيادة حماس يعني انه "في حرب ضد ا لا سلام

- (c). Trs: (*ben laden: hareb salebleebayah ded al eslam...*)

Qala osama ben laden z 'eem tandeem al qa'eda fi tasjeel sawti mansub eleih ena taharuk alghrb l 'zel al hukuma al filisteenyh biqeyadat hamas y'ni enahu fi harb ded al eslm)

The underlined constituents of the ST in (1) (a), *the fugitive al –Qaeda leader's*, is given a syntactic structure in (a), its corresponding Arabic translation, *زعيم تنظيم القاعدة* (*z'eem tandeem al qa'eda*), is given the structure in (b), as illustrated:

(a) ...the fugitive al Qaeda leader...

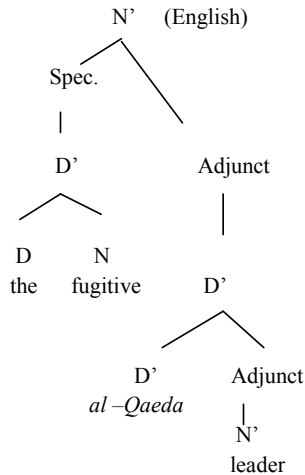

(b) زعيم تنظيم القاعدة

(...z'eem tandeem 'al qa'eda...)

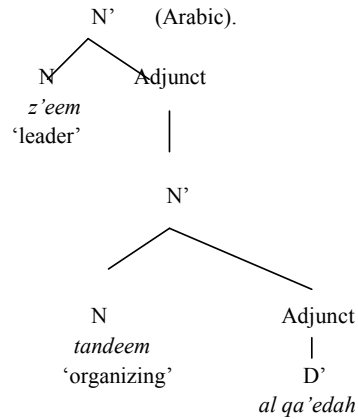

In the above *phrase markers*, the non-branching node like *Adjunct* is retained. In the subsequent representation, following a representation in linguistic convention that non-branching node deletes itself, only when it is necessary that the *Adjunct* node will be represented.

In the above example, it is noticed that the Arabic term *القاعدة (al-Qaeda)* is borrowed from Arabic to be used in the English political news in (1)(a). The translator uses the same determiner phrase in the TT in (1)(b) as evidenced from its transliteration in (1)(c). Syntactically, it is also noticed that the same determiner phrase is sandwiched between two constituents, *the fugitive* and *leader*. As *القاعدة (al-qa'eda)* is an Arabic determiner phrase. The translator retains it in the Arabic news as in (1)(b). As for the phrase *al-Qaeda leader's* which has the structure [D'-N'] as in (a') above has

changed to *زعيم تنظيم القاعدة (z'eem tandeem al-qa'eda)* which stylistically is [N-N-D'] sequence as in (b') above. The structural difference is that the political terms *al-Qaeda'* is written after two nouns, namely *زعيم (z'eem)* 'leader' and *تنظيم (tandem)* 'organizing'. In addition, it is noticed that the translator has uses the definite article *ال (al)* 'the' to make the noun definite in both the ST and the TT texts.

In terms of Ghazala's (1995) ideas on styles, the above syntactic change can be termed as a formal style as the complex and long sentences have been retained. In other words, in terms of style in Ghazala's sense the sequential syntactic change from "...the fugitive al-Qaeda leader's..." (D'-D'-N') in English to Arabic "زعيم تنظيم القاعدة..." (z'eem tandem al-qa'eda) ..." (N-N-D') has been kept to a minimum as it only involves a change in the syntactic position of the noun

leader (Arabic زعيم *z'eem*). In addition, the English phrase *the fugitive al-Qaeda leader's* is expressed in the possessive (genitive) case, while the Arabic translation زعيم تنظيم القاعدة (*z'eem tandem al-qa'eda*) is an adjectival constituents in an adjective position.

2. (a) ST: **Iraqi Shias state coalition terms**

BBC: Saturday, 21st January 2006

The Shias bloc which took the most voters in Iraq's election says it will form a coalition with Sunni groups but only if they do more to combat the insurgency.

2. (a) ST: The Shia bloc ... says it will form a coalition with Sunni groups...

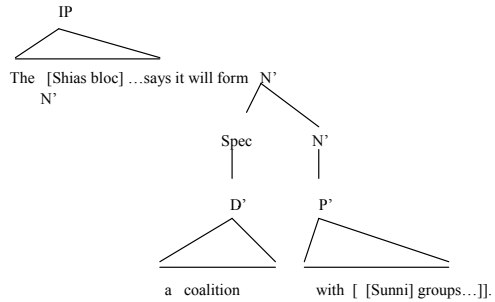

(b')السننيه..... الائتلاف العراقي
 الشيوعي الموحد
 (*a-etlaf al-'iraqi al-shee'eyah al-muwahad al-suneeiyah...*)

(b) TT: احزاب الشيعة العراقية تضع شروطا
 للائتلاف مع السنة

اعلن زعماء الائتلاف العراقي الشيوعي الموحد الذ
 ين يتراسون اكبر تكتل في لابرلمان العراقي
 الجديد انهم سيشكلون ائتلافا حكوميا تشارك
 فيه الاحزاب السننيه , لكنهم اشترطوا لتحقيق
 ذلك قيام هذه الاحزاب ببذل جهد اكبر في
 المواجهه مع المسلحين

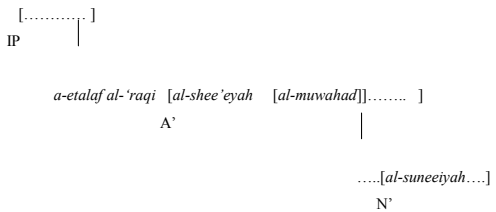

(c) Trs: *a'lana zua'ma al-etlaf al-iraqi al-shee'ee al-muwahad al-lathina ytarasuna akbar takatul fi al-barlaman al-'raqi al-jadid anahum sayoushakiluna etelafan hukumeeyan tusharik fih al-ahzab al-suneeyah, lakinahum eshtaratu li tahqiq thalika qiyam hathih al-ahzab bibathl juhda akbar fi al-muajaha ma'al-musalaheen.*

In the English ST as in (2)(a), the terms *sunni* and *shia* are borrowed from Arabic.

The Arabic translation retains them. However, there is a change of grammatical category. The word *shia* is a noun in the ST but is used as an adjective *الشيعة* (*al-shee'ee*) in the TT. Besides, in the ST *The sunni bloc* is a global determiner phrase referring to the whole group while in the Arabic TT the determiner phrase *الشيعة* (*al-shee'ee*) has a more definitive reference. As for the determiner phrase *السننيه* (*as-Sunni*), it is an adjective in the ST but it has been translated as a definite noun in the TT text.

Based on Ghazala's (1995) views of styles, it is quite apparent that the long

The following tree diagrams in (a') to (b') in (2) below demonstrate the syntactical difference:

sentence style of the ST has been transferred to the TT. In addition the formal style of the original has been maintained. The determiner phrase *the Shias bloc* which in the ST is a subject of the main clause has shifted its position in the subordinate clause in the Arabic TT. This is similar to the movement of words (namely *fronting*) in Ghazala's (1995) sense.

3. (a) ST: Bin Laden's call falls on deaf ears ...

BBC Monday, 24th April 2006.

'we are not concerned with any mujahideen or any crusade or any war with the International community.'

- (b) TT: “

وقال "ادعو المجاهدين و مسانديهم , خاصة في السودان و شبه الجزيرة العربية الى الاستعداد لحرب طويلة " ضد الصليبيين في غرب السودان

- (c) Trs: (*Wa qala " ada'u al mujahideen wa musaneedehum.....*)

The labeled bracketing in (a-b) below shows the syntactic difference between the sequential arrangement of the words in the ST and the TT:

- (a') ST: We are not concerned with any Mujahideen or any crusade...

[[we] [are not [concerned] [with [any Mujahideen or any crusade...]]...]]..

- (b') TT: ادعو المجاهدين و مسانديهم

... *ad'u al mujahideen wa musaneedehum...*

[[ada'-u -au [[al-Mujahideen [wa musaneedehum...]]]]].

IP V' N' IP Con

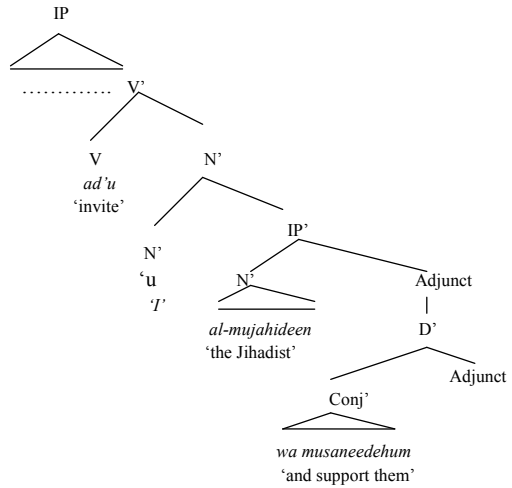

First, English has borrowed the word مجاهدين (*mujahideen*) and the Arabic translation has retained this. In addition, the word مجاهدين (*mujahideen*) is a noun in both the ST and TT, but its position in the TT text has been shifted, that is in Ghazala's (1995) view of movement of elements in a sentence (i.e., fronting). In this case, the English S-V-O (subject-verb-object) sequence in the ST has been changed to V-S-Comp (verb-subject-complement) in which the subject is recorded as a suffix bound-morpheme of the Arabic verb. In addition, the word مجاهدين (*mujahideen*) in the ST text is conjoined with another noun by the conjunction.

Stylistic Changes Due to Calque.

This section examines a special kind of borrowing of an expression from another language but translating it literally either as (a) a lexical *calque* introducing a new mode of expression or (b) a structural *calque* which introducing a new construction into the language (Vinay & Darbelnet, 1995, p.32). After a period of time, some *calques* become an integral part of the language, while some others undergo a semantic change, turning them into *faux amis* ‘a false friend’ which are words that seem quite familiar to a speaker of a receptor’s language but actually mean different things in the foreign language.

4. (a) ST: ‘Maliki endorsed as new Iraqi PM’

They also gave the post of parliament speaker to Mahmoud al-Mashhadani, a Sunni Arab.

- (b) TT : الما لكي : اريد تشكيل حكومة تمثل اطبا يف : المجتمع العراقي

كما اختير محمود المشهداني, و هو سني رئيسا للجمعية الوطنية

- (c) Trs: (*al maleki :ureed tashkeel hukuma tuamathel atyaf al mujtm’ al ‘raqi)(kama aqra al barlaman entekhab jalala al talabani , wa huwa kurdi, raesan lil bilad liftra welayah thaneyah. Kama ukhteera mahmud almashhadani , wa huwa suni raeesan li-l jam’eeyah al wataneeyah.*)

We are concerned with the English noun phrase ...*the post of Parliamentary*

Speaker.... which has a structure in (a’) and its corresponding Arabic structure in (b’) as illustrated below:

- (a’) ST: ...the post of Parliamentary Speaker...

[[[the [post] [[of [Parliamentary Speaker]]]]]].

N’ Spec D’ NP’ P N’

- (b’) TT: الوطنية رئيسا للجمعية (...*raeesan li-l jam’eeyah al wataneeyah*...).

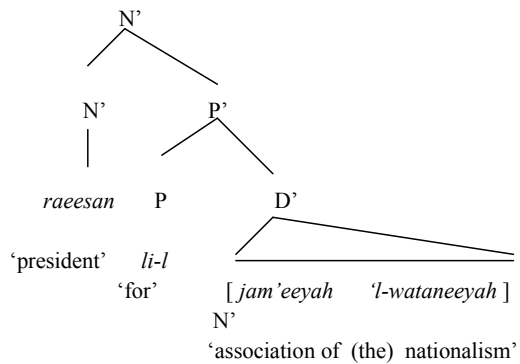

From (a-b) above, the concept behind the phrase ...*the post of Parliamentary Speaker*... with a structure of [D’-P-N’] has been translated into Arabic as رئيسا للجمعية الوطنية (...*raeesan lil jam’eeyah al wataneeyah*...) with a structure [N’-P’-D’]. In particular, two sequential words *Parliamentary Speaker* in English have become a sequence of a noun, a prepositional phrase and a determiner phrase, namely رئيسا (*raeesan*) ‘president’, الجمعية (*lil-jam’eeyah*) ‘for the association’ and الوطنية (*al-wataneeyah*) ‘the nationalism’. They are different not only syntactically but also in terms of words. Morphologically, the Arabic translation has added the definite

article ال (*al*) ‘the’ for both جمعية (*jam’eeyah*) ‘association’ and وطنية (*wataneeyah*) ‘nationalism’. The English-Arabic translator has used the nunation (or *tanween*) appended to Arabic nouns to indicate that the word is indefinite for رئيسا (*raeesan*) ‘president’. The syntactic and the lexical changes in both (a) and (b) above are in line with Ghazala’s (1995) view of formal style of language.

5. (a) ST: ‘US warns Russia over aid to Iran’

BBC: Wednesday, 19th April 2006.

...said Mr. Burns, the US undersecretary of State...

(b) TT: مطالبة أمريكية لموسكو بوقف مساعدة إيران نوويا

... وقال برنز نائب وزير الخارجية الأمريكية

(c) Trs: ...*washington tad’u rusyah le elgha safqat al sawareegh ela eran wa hatha nikulas bireez naaab wazeerat al khareejeyah al amreekiyah*

...

We are interested in the text ...*the US undersecretary of state*... which has a structure in (a) and the structure of its corresponding Arabic translation is in (b) below:

(a’) ST: ...the US undersecretary of State

naaab wazeerat al khareejeyah al amreekiyah

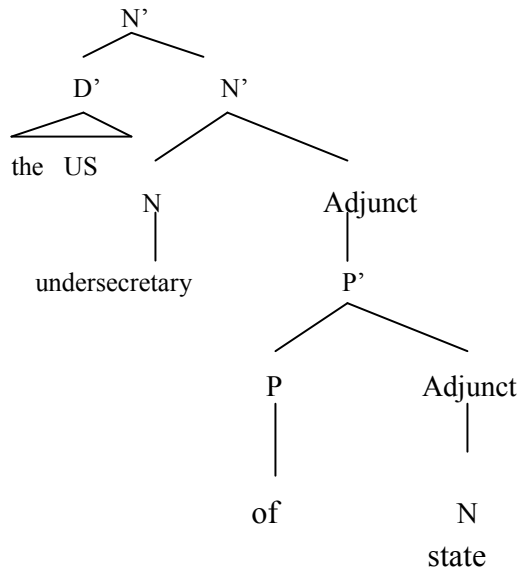

(b) نائب وزيرة الخارجية الأمريكية

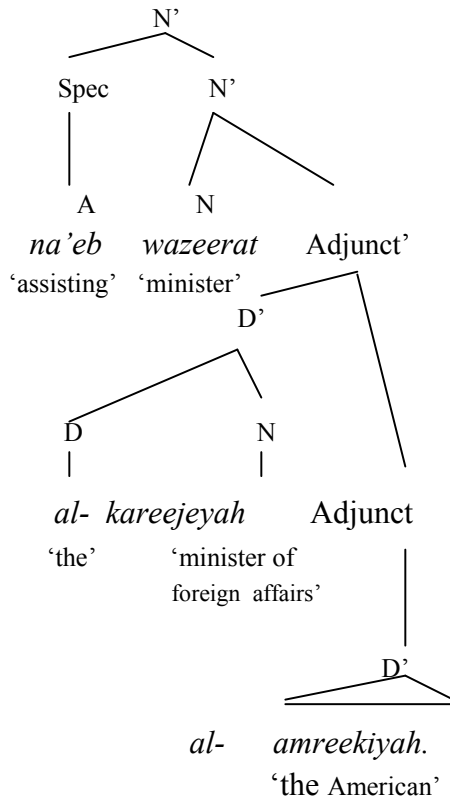

It is observed that the English phrase *the undersecretary of state* is a sequence of a determiner phrase, a noun and a prepositional phrase: [D'-N-P']. In the Arabic translation, this has changed into نائب وزيرة الخارجية الامريكية (*naeb wazeerat al khareejyah al-amreekiyah*), a sequence of words containing an adjective, a noun and two determiner phrases: [A-N-D'-D']. The translator does not literally translate each element, but has used structural and stylistic changes to create a syntactical and structural equivalence between the ST text and the TT. The definite article ال (*al-*) 'the' in الخارجية (*al-kharejeeya*) 'the exterior, foreign' and الامريكية '*al-amreekiyah*' 'the American' are used in determiner phrases (D') to define the nouns and to express a shared knowledge about certain entities. The same corresponding expressions in the ST text are undefined. In terms of Ghazala's (1995) views on style, the structural change in the Arabic TT is in keeping with a formal style of the ST.

6. (a) ST: 'Iraq Shia alliance to vote on PM'

BBC: Friday, 21st April 2006

Iraq's largest parliamentary bloc, the United Iraq Alliance (UIA), is to vote on a candidate for prime minister. The Shia Muslim coalition's vote could see Prime Minister Ibrahim Jaafari retain power or introduce a new leader

- (b) TT: الجمعية الوطنية العراقية تنضرب في
ترشيح المالكي

تعقد الجمعية الوطنية العراقية (البرلمان) اجتماعا
اليوم السبت للمصادقة على عدد من المناصب
السيادية في

الدولة بما فيها اكثر هذه المناصب اثاره للجدل و هو
منصب رئيس الحكومة .

(c) Trs: (.... *al jam'yah al wataneeyah al 'raqeeya tandur fi tarsheeh al maliki t'qeed al jam'yah al wataneeyah al 'raqeeyah (al barlaman) ejtema'n al youm al sabt lil musadaqa 'la 'dad min al manaseb al seyaseyah fi al dawla bima fiha akthar hadheh al manaseb ethara lil jadal wa huwa mansab raees al hukuma.*)

We are concerned with the English genitive noun phrase *Iraq's largest Parliamentary bloc* in (6)(a), its corresponding Arabic translation in (b) and its transliteration in (c) above. Compare the English structure in (a') in labeled bracketing with its Arabic counterpart in a phrase marker configuration in (b') below:

(a') ST: ...Iraq's largest Parliamentary bloc...

[[Iraq's [largest]] [Parliamentary [bloc]...]

N' N' A' A' N

(b') TT: الجمعية الوطنية العراقية (البرلمان)

al jam'eeyah al wataneeyah al 'raqeeyah (al barlaman)

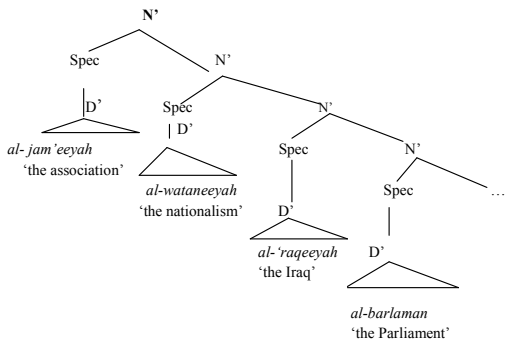

Obviously, there is a *calque* in the Arabic term برلمان (*barlaman*) ‘parliament’ with an adaptation in its original spelling *parliament*. However, there is, no change in the grammatical category from a noun in the English word *parliament* to the Arabic word *barlaman*. The overall structure of the English genitive compound noun phrase of [N’-A’-[A’-[N]]] has been changed drastically into a series of determiner phrases [D’-D’-D’-D’] where each one contains a definite determiner phrase with a definite article ال (*al*) ‘the’ in the Arabic translation. With respect to the English adjectival phrase *parliamentary bloc*, the consecutive adjective-noun sequence, [A’-N], has changed too; it now occurs after three determiner phrases الجمعية (*al-jam’eeyah*) ‘the association’ الوطنية (*al-wataneeyah*) ‘the nationalism’ and العراقية (*al-rqeeyah*) ‘the Iraq’. The English word *largest* is left translated. In terms of Ghazala’s (1995) view, the Arabic translation such as the one here which contains a series of determiner phrases in (b) is a form of Arabic formal writing style where the noun is properly identified with its respective definite article. Consequently, the sentences remain long.

Stylistic Changes Due to Literal Translation.

In this section we present a few cases of stylistic changes due to literal translation.

7. (a) ST: ‘Maliki endorsed as new Iraqi PM’.

US president George W Bush said the “historic achievement by

determined Iraqis will make America more secure...”

BBC: Saturday, 22nd April 2006

(b) TT: المالكي : اريد تشكيل حكومة تمثل اطراف المجتمع العراقي

ورحب الرئيس الامريكي جورج بوش با لا تفاق الذي توصلت اليه الكتل السياسية في العراق و اعتبر ان ” هذه الخطوة ” ستجعل الولايات المتحدة اكثر امنا

(c) Trs : *wa rahaba al-raees al-amriki jourj bush bi-alitifaq alathi tawasalat elih al-kutal al-seyaseeyah fi al-‘raq wa a’tabar ana hathih al-khitua “ sataja’l al-wilayat al-mutahida akthar amanan ”*

We are concerned with the verb phrase ...*will make America more secure*. It has a sequential structure in (a’). The structure of the corresponding Arabic translation is as in (b’) below:

(a’) ST: ...*will make America more secure...*

[... [[will [make [America [... [more secure]]]]]]]

IP I’ I V’ N’ COMP A’

- (b') TT: ستجعل الولايات المتحدة اكثر امنا (...*sa taj'al al weylayat al mutaheda akhtar amanan*).

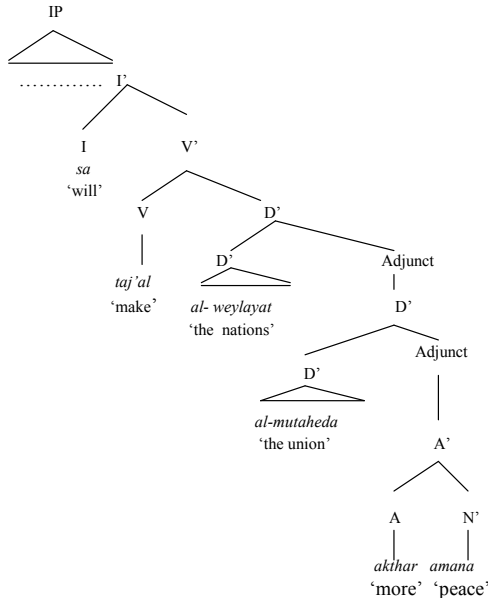

From the above English data and its corresponding Arabic translation in (a-b), it is observed that the translator has translated some of Bush's statement ...*will make America more secure* literally into Arabic text. It is noted that it consists of five lexical words, namely a modal *will*, a verb *make*, a proper noun *America* and adjective *secure*. Its structure is as in (a) in labeled-bracketing above. Translating the original sense literally into Arabic produces a rather different structure as in (b). What used to be a sequence of [modal-verb-N' - COMP[- A']] as in (a) in English has become [modal-V-D'-D'-A'] in Arabic, as in (b') above. In terms of Ghazala's (1995) ideas of styles, the Arabic version is a formal and repetitive language usage in keeping with the original formal style of the ST.

8. (a) ST: Iran fears drive oil to new high.
Crude oil prices have risen still higher amid fears about continuing tensions between Iran, a key exporter, and the International community.

BBC: Tuseday, 18th April 2006

- (b) TT: ازمة الملف النووي الايراني ترفع اسعار النفط و الذهب
و يرى محللون ان استمرار التوتر سيدفع ال
سعار في اتجاه المزيد من الارتفاع بشكل تتجاوز
معه قريبا سعر دولار للبرميل .

- (c) Trs: ...*Azmat al malaf al nuwauwi al erani tarf' as'ar al naft wa al thahab*

The following structure of (8)(a) and the tree diagrams of the corresponding Arabic translation in (b) show the syntactic difference between the SL and the TL:

- (a) ST: Iran fears drive oil to new high...
[[Iran fears] [drive [oil [to [new high]]]].

IP N' V' N' P' A'

- (b) ازمة الملف النووي الايراني ترفع اسعار النفط و الذهب
(Azmat al malaf al nuwauwi al erani tarf' as'ar al naft wa al thahab...)

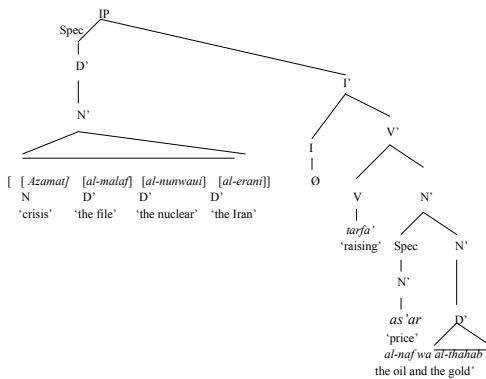

sentence still keeps the formal nature of the original English ST.

9. (a) ST: “ Bin Laden call falls on deaf ears’

‘Our goal is not defending the khartum government but to defend Islam its land and its people’, he said.

BBC Monday, 24th April 2006

- (b) TT: ”بن لادن“ حرب صليبيه غربيه ضد لا

سلام

”و اضاف“ ان هدفنا ليس الدفاع عن حكومة
الخرطوم و انما الدفاع عن الاسلام و ارضه و
شعبه

- (c) Trs: (bin laden: hareb salebeebyah gharabiyah ded al e’slam)

(wa adafa ena hadafana leis al defa’ ‘an hukumat al khartum wa enama al defa’ ‘an al eslam wa ardeh wa sh’bih.)

The syntactic structure of the ST is a complex noun phrase as a subject followed by predicate consisting of a verb, a noun and a complex prepositional phrase. The English word order of [N’-[V-N-P’-A’]] becomes a sentence comprising a complex noun-phrase-subject consisting of a noun and three determiner phrases in Arabic: [N-D’-D’-D’] followed by a predicate [V-N’-D’]. In general, the order in both cases is S-V-O/ (complement). In Ghazala’s (1995) terms, the apparent similarity of S-V-O word order in both cases makes the Arabic translation somewhat literal in nature. This is so because the S-V-O word order is basic for English while it is not normal in the Arabic translation neither in keeping with the norm of Arabic syntax which is basically a VSO word order. In addition, although the object (complement) of the verb in the English ST is merely a simple noun *oil*, its counterpart in the Arabic translation is a conjoined noun phrase *النفط و الذهب* (*al naft wa al thahab*) ‘oil and the gold’. It has been added a new element *the gold* in it. Apart from that, the Arabic

We are concerned with the underlined constituents of the texts in (a-c) above. Sentence (9)(a) above has the structure as the phrase marker (tree diagram) in (a) below, while its Arabic counterpart has the structure in the phrase marker (b’):

- (a) ‘Our goal is not defending the khartum government but to defend Islam its land and its people’,

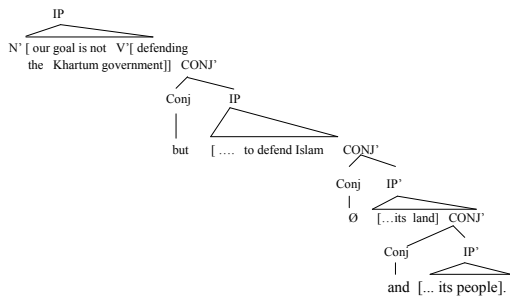

(b) ان هدفنا ليس الدفاع عن حكومة الخرطوم و
 انما الدفاع عن الاسلام وارضه و شعبه
 ('ena hadafana leis al defa' 'an hukumat
 al khrtum wa enama al defa' 'an al
 eslam wa ardeh wa sh'bih.)

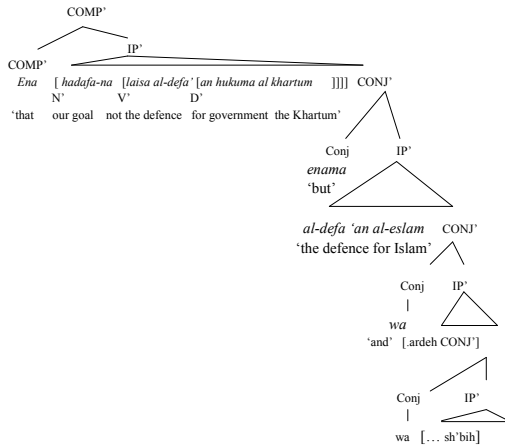

It is noticed that the translator has respected most of the words when translating the ST into Arabic text. It is also observed that there is some structural stylistic correspondence between the ST text and the TT text. Basically, both are similar: one principal clause followed by a series of conjoined clauses. Hence, it is in keeping with a literal translation discussed under this heading. The only difference is that the Arabic sentence is introduced by a complementizer ان (ena) 'that'. In addition, there is an obvious introduction of the definite article ال (al) 'the' in some of the Arabic words such as الخرطوم (al-Khartum) 'the Khartum', الدفاع (al-defa) 'the defence', الاسلام (al eslam) 'The Islam' when these definite articles do not exist in the corresponding ST text. This is in keeping with Hatim's (1997) view that

it is culturally inherent in Arabic to begin a sentence with a clause introducer, 'a complementizer' and to use a definite article when the content discursively calls for the use of the definite article such as in the case of الخرطوم (al Khartum) 'The Khartum', الدفاع (al defa) 'the defence' to show the sharing of knowledge about entities.

In Ghazala's (1995) terms, both languages keep the formal style. For example, the subject of the repeated clauses is truncated in both English and Arabic. The idea behind the use of conjunctions and the deletion of the repeated 'common' subject noun phrases is to achieve better cohesion between the clauses.

Stylistic Changes due to Adaptation.

In this section, we will examine three cases of lexico-political terms found in the English ST; however, they do not have their one-to-one equivalence in the TT. These are anti-Semitism, parliamentary speaker and democracy. We will look at the way they are adapted in the Arabic texts. They are adapted as in the data in (10) through (10) below:

10. (a) ST: Mr. Sharon has now praised France's efforts in combating anti-Semitism.

(b) TT: شارون في باريس لا جراء محادثات مع شيراك

و يتوقع ان يستخدم شارون الزيارة لامتداح الحكومة الفرنسية للخطوات التي اتخذتها لمكافحة معادات السامية

(c) Trs: sharun fi barees li ejra muhadathat m'sherak

wa yatawaq' an yastakhdem sharun al zeyara li mtedah al hukumah al faranseeyah lil khetwat al lati etakhadhatha li mukafahat mu'adat al sameeyah.

11. (a) ST: Other posts due to be endorsed on Saturday include the president and parliamentary speaker and their deputies.

(b') TT: الجمعية الوطنية العراقية تنضر في ترشيح المالكي

و من المقرر ان يبحث البرلمان منصبي رئيس الجمهورية و رئيس البرلمان

(c) Trs: *jam'eeyah al wataneeyah al 'raqeeya tandur fi tarsheeh al maliki Wa min al muqarar an yabhath al barlaman aeydan mansebei raees al jamhureeyah wa raees al-barlaman*

12. (a) ST: He offered his congratulations to the Iraqi people and said the day was a milestone on Iraq's path to democracy.

(b) TT: المالكي : اريد تشكيل حكومة تمثل اطراف المجتمع العراقي

و قال بوش في خطاب القاه بساكرامنتو بولاية كاليفورنيا ان الاتفاق يعتبر " انجازا هاما" في الطريق نحو " الديمقراطية" و انه يجسد التوافق و الاجماع

(c) Trs: *al maleki : ureed tashkeel hukuma tumathel atyaf al mujtam' al 'raqi wa qala bush fi khetab alqah bisakra mintu biweelayat kaleeforneyah ena al etefaq yatabur " enjazan haman" fi al tareeq nahwa al demuqrateeyah wa enahu yujassed al tawafiq wa al ejma'.*

From (10-12) above, it is noticed that only the term *democracy* in (12) (a) is adapted entirely in Arabic with an adaptation in terms of its spelling. The only difference is that in Arabic it appears with the definite article لا (*al*) 'the' in *الديمقراطية* (*al demuqrateeyah*) 'the democracy'. In the case of the term *parliamentary speaker* in (11)(a), a cluster of adjective and a noun of the structure [A'-N'], the ST is perceived by the Arab translator in Arabic as a series of a noun and a determiner phrase: [N'-D'], *رئيس البرلمان* (*raees al barlaman*) 'president the parliament'. Hence, stylistically they are different. With respect to the term *anti-semitic* in (10)(a) above, the term in the English ST has a simple structure of [Neg-N]. It does not seem to be translatable easily as in Arabic it appears as a cluster of two prepositional phrases: [P'-P'], *الديمقراطية* (*li mukafahat mu'adat al sameeyah*) 'for fighting against the Semitism'. So it is expressed in different style.

Stylistic Changes Due to Modulation.

In this section, we will examine three English political terms of the ST and how they are translated in the corresponding Arabic TT. It is shown that due to their inability to be adapted, the translator has resorted to express the above political terms according to the purpose of the TT. These political terms are *deputy speaker*, *parliamentary speaker* and *undersecretary of state*.

The differences in style are noticeable from the structures (13) through (15) below:

13. *deputy speaker*, [N'-N'] نائب رئيس البرلمان (*naeb raees al barلمان*) 'deputy head the parliament', [A'-N'-D'].

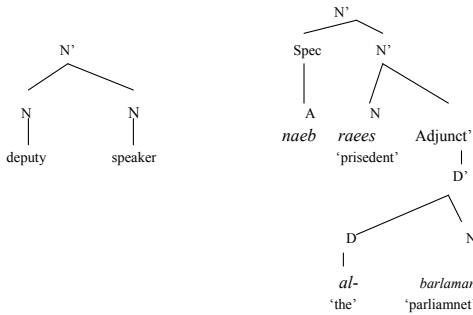

14. *parliamentary speaker*, [A'-N'] رئيسا للجمعية الوطنية (*raeesan lil jam'eeyah al wataneeyah*) 'president for association the nationalism', [N'-P'-D'].

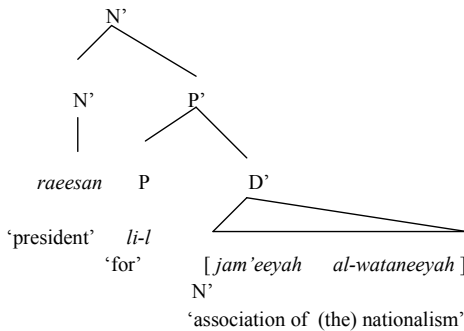

15. *undersecretary of State*, [N'-P'] → المبعوث الامريكي (*al maba'uth al amreeki*) 'the envoy the American', [D'-D'].

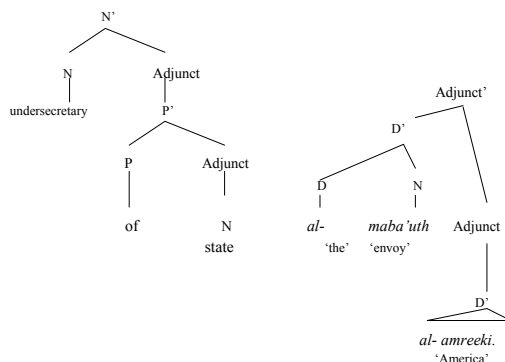

It is observed that whether it is a nominal compound, an adjectival phrase or a series of determiner phrases, the styles in the TT texts are different.

Stylistic Changes due to Equivalence (Paraphrases).

16. (a) ST: Maliki endorsed as new Iraqi PM .

BBC: Saturday, 22nd April 200.

But he added that there would be strong competition among the various movements for key posts such as the interior, defense, foreign and oil Ministers.

- (b) TT: الما لكي : اريد تشكيل حكومة تمثل اطياف المجتمع العراقي

الا انه يرى ان التنافس سيكون شديدا بين مختلف الكتل السياسية على الحقايب الوزارية الهامة كالداخلية و الخارجية و الدفاع و النفط

- (c) Trs: *ala enahu yara ana al tanafus sayakun shadeedan beina mukhtalef al katal al seyaseeyah 'la al haqaeb al wezareeyah al hama kdakheleyah wa al kharejeyah wa al defa' wa al naft.*

The underlined constituents in the English ST in (16)(a), *among the various movements for key posts*, is a series of prepositional phrase, an adjective and a prepositional phrase of the structure [P'-[A'-P']]. Unable to translate the sense by using the same structure, the translator has used a suitable paraphrase to reflect the same idea in Arabic as *بين مختلف الكتل السياسية* (*beina mukhtalef al katal al seyaseeyah*) 'between different the bodies the politics'

of the *structure* [[P-A'-D'-D']]. Here, there is apparently a change of syntactic style.

17. (a) *ST: US troops on Iraq abuse charges.*

BBC: Wednesday, 27th July 2005

(b) TT: اتهام جنود امريكيين بسوء معاملة
سجناء عراقيين

(d) *etaham junud amreekiyeen bi sua mu'amalat sujana a'raqeyen*

The English ST in (17)(a) and its Arabic translation in (17)(b) have the structures in (a') and (b') respectively below:

(a') ST: US troops on Iraq abuse charges.

[[[[US [troops] [on Iraq]]]]]
[abuse [charges]]].

IP' IP Spec A' N P V' N'

(b') اتهام جنود امريكيين بسوء معاملة
سجناء عراقيين

etaham junud amreekeyeen bi sua mu'amalat sujana a'raqeyen

[...[*etaham [junud [amreekeyeen]]*
[bi [sua] [mu'a'malat]

V' N' A' P' A' N'

'charging' 'soldiers' 'American' 'by bad treatment'

[*sujana ['raqeyen]*

A' N

'prisoners' 'Iraqian'

The English headline in (a') above is a complex sentence containing a relative clause as subject [A'-N']- [V'-N']]. The

[[sentential-subject] structure of the ST has been changed stylistically in Arabic to a nominal clause of the structure [[N'-A'] -[P [A'-N]- [A'-N]]]. The two examples examined here show that translators may resort to a paraphrase as an alternative equivalence.

Stylistics due to Passive Sentences

In this section we consider two cases of the English ST that need to be rephrased to their suitable equivalence in the TT. We consider (18) and (19) below:

18. (a) ST: US warns Russia over aid to Iran

Enriched uranium can be used as fuel in a nuclear activity, or, when highly refined, in a nuclear weapon.

(b) TT: مطالبة امريكية لموسكو بوقف مساعدة ايران
نوويا

و يمكن ان يستخدم اليورانيوم المخصب في مفاعلات توليد الطاقة , او في صنع الاسلحة النووية و ان كان هذا الاخير يحتاج الى درجة عالية من التخصيب

(c) Trs: *mutalaba ameekiya li mosko biwaqf musa'adat eran nuwawiyen*

Wa yumkin ann yustaikhdam al-yuranium al-mukhasab fi mafa'lat tawlid al-taqa, aw fi sun'a al-asliha al-nuwawiya wa en kana hatha al-akhir yahtaj ela daraja 'aliya min al-takhsib.

The English ST in (19)(a) and its Arabic translation in (19)(b) have the structures in (a') and (b') respectively below:

(a) ST: Enriched uranium can be used as fuel in a nuclear activity...

[[enriched uranium] [[can [be
]]] [used [as]]]]

IP' Spec I' Modal Aux V' Conj

(b) TT: ويمكن ان يستخدم اليورانيوم المخصب في

Wa yumkin ann yustaikhdam al-
yuranium al-mukhasab...

[[wa [[yumkin [ann [ustakhdam
[al-yuranium]]]]]]

Conj I' Modal Comp A' D'

'and + might + that + used +
Uranium'

From the above analysis, it is noticed that the ST contains the passive form *can be used* whose structure is [I' -[Mod-Aux]-[V']]. Consequently, the Arabic version is translated as [-Conj' [I' [Modal [Comp-[V']]]]]. The style of the passive sentence is to concentrate on the action/patient while suppressing or ignoring the agent of the action. The translator has reflected a similar function, when he/she concentrates only on the action of the sentence during the translation. Thus, the passive form of *can be used* is translated as it is along with a complementizer ان (anna) 'that'.

In the next example, we consider English ST, *was kidnapped several weeks ago* in (20)(a) and its Arabic translation in (20)(b) below:

20. (a) ST: US soldiers in Baghdad fighting

Taha al-Mutlaq, a businessman, was
kidnapped several weeks ago, and
found shot in the head.

(b) TT: قتال عنيف في الرمادي و بغداد

و كان طه المطلق- و هو رجل اعمال- قد اختطف
قبل عدة اسابيع ثم عثر على جثته بعد اطلاق
الرصاص على رئسه.

(c) Trs: qital 'nif fi al-rumadi wa
Baghdad

Wa kana taha al-mtlaq- wa huwa rajul
a'mal -qad aukhtutifa qabla 'dat asabee'
thuma 'uthira 'la guthathihi b'ada itlaq
al-risas 'ala rasih.

The English ST in (20)(a) and its Arabic translation in (20)(b) have the structures in (a') and (b') respectively below:

(a) ST: Taha al-Mutlaq, a businessman,
was kidnapped several weeks ago....

[[[Taha al-Mutlaq [[a
businessman]]]] [was [kidnapped [
several weeks ago ...]]]]

IP' Spec IP' IP D' I' V' Adjunct

(b) و كان طه المطلق- و هو رجل اعمال- قد
اختطف قبل عدة اسابيع

[wa [kana [[taha al-mtlaq wa huwa
rajul]] [a'mal [qad [aukhtutifa 'dat
asabee' .]]]]]]

Conj IP' +past N' IP' Conj V Adjunct

'and' 'was' 'Taha al-mutlaq - and he
man might arrested several weeks...'

From the above analysis in (a), it is noticed that the ST is a complex sentence. It has an appositive relative clause as its subject. The main clause is in the passive form with the verb phrase *was kidnapped* followed by an adjunct, (*several weeks ago*). The overall structure is [Subject

(Relative clause) –Predicate (Passive-adjunct)]. Consequently, the Arabic version is translated as [Conj’-[IP’ (+past)-N’ (IP’)] –Conj [V’-adjunct]]. The style of passive is to concentrate on the action and suppress the agent of the action. The translator has reflected similar functions in Arabic in his/her translation.

21. (a) ST: Maliki endorsed as new Iraqi PM.

They also gave the post of Parliament speaker to Mahmood al Mashhadani , a sunni Arab ...

(b) TT: كما اختير محمود المشهداني وهو سني رئيس للجمعية الوطنية

(c) Trs. *Kama ukhteera mahmood al mashadani wa hua suni raees lil jam’eeyah alwataneeyah.*

The English ST in (21)(a) and its Arabic translation in (21)(b) have the structures in (a’) and (b’) respectively below:

(a) They also gave the post of.....

[... [also [gave]the post of....]
IP Adv V D N P

(b) كما اختير محمود المشهداني وهو سني رئيس للجمعية الوطنية

[*Kama* [*ukhteera* [*mahmood al mashadani*....]

CONJ V N

also chosen Mahmood al-mashadani....

(passive)

From the above analysis, it is noticed that the SL text is a simple sentence, the main

clause contains the active form *gave* ... the structured [V’]. Consequently, the Arabic version is translated as [Conj’-passive V’]. The style of active is changed into passive form *ريختها امك* (*Kama ukhteera*), literally: also chosen’ in the Arabic version. The translator has reflected a similar idea of election, but in different grammatical style, because the translator has ignored the agent of the action in the Arabic version.

Stylistics due to Long Sentences

In terms of long sentences, we will only show the structure of the complex sentences in terms of how they are connected to each other without detailing the internal structures.

22. (a) ST: Bolton appointed US envoy to UN

Confirmation hearings hit headlines during the spring but became mired in debate as the Senate readied itself to consider the nomination of John Roberts to the US Supreme Court.

(b) TT: تعيين بولتن مبعوثا لواشنطن لدى الامم المتحدة

و كانت الجلسات الخاصة بتاكيد الترشيح قد تصدرت عناوين الاخبار خلال الربيع, ولكن الامر غاص في ساحة من الجدل في الوقت الذي اخذ مجلس الشيوخ يتاهب للنظر في ترشيح جون روبرتس للمحكمة الامريكية العليا.

(c) Trs: *t’yeen bultin mab’uthan li-washintun lada al-umam al-mutahida Wa kanat al-jalasiat al-khasa bi takeed al-tarshih qad tasadarat ‘anween al-akhbar khilal al-rabee’ , wa lakin*

al-amr ghasa fi saha min al-jadal fi al-waqt alathi akhatha majlis al-shiyoukh yataahab lil nadar fi tarshih jun Roberts lil mahkama al'ulya .

Now, we will consider an example of a long sentence of the English ST in (a) and its Arabic version in (b) below:

(a) [[Confirmation hearings hit headlines during the spring]]

IP' IP
 [but [[became mired in debate [as
 [the Senate readied itself
 Conj IP' Comp IP'
 [[to consider the nomination of John
 Reborts to the US Supreme Court.]]]]]].

Comp' IP'

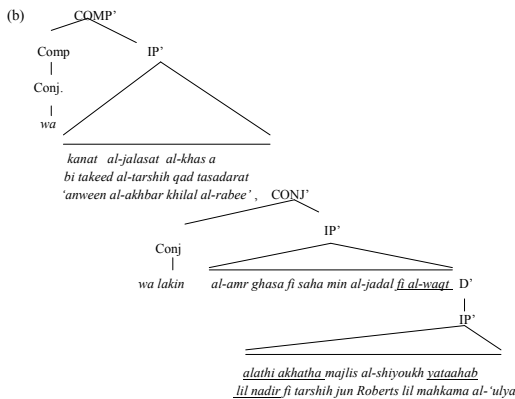

From (22)(a-b) above, it is noticed that the ST is a conjoined sentence in which the subordinate clause is a series of three verb phrase complements. The corresponding Arabic translation is also a conjoined sentence, but the subordinate sentence is

a relative clause. The ST and the TT are different in terms of the way the sentences are connected. In Arabic, the conjunction comes in a clause initial position: و (wa) 'and', ولكن الامر (wa laken al amr) 'but the matter'. In the ST, the conjunction joins two clauses somewhere in the middle of the long sentence. Based on Ghazala (1995) view, the long sentence is a normal style that is often used in Arabic language.

Stylistics due to Repetitions and Variation.

In this section we will consider two cases of repetitions. We consider the first case in (23) through (25):

23. (a) ST: Sharon arrives in Paris for talks

He is expected to discuss the forthcoming pullout from the Gaza Strip with President Jacques Chirac. Mr. Chirac has described the withdrawal as courageous, and is expected to urge more Israeli moves to keep momentum towards peace in the Middle East. Mr. Sharon, for his part, is expected to use the visit to praise the French government for its action against anti-Semitism in France

(b) TT: شارون في باريس لاجراء محادثات مع شيرك شيرك

ومن المتوقع ان تتم مناقشة الانسحاب المرتقب من قطاع غزة. ووصف شيرك الانسحاب بانه خطوة شجاعة. ومن المتوقع ان يحث شيرك لاسرائيليين على القيام المزيد من الخطوات للمحافظة على الدفع باتجاه السلام في الشرق الاوسط. ويتوقع ان يستخدم شارون الزيارة لامتداح الحكومة الفرنسية للخطوات التي اتخذتها لمكافحة معاداة السامية

(c) Trs: sharun fi barees li-ejra muhadathat m' shirak

Wa min al-mutawaq'a ann tatim munaqashat al-insihab min qata' ghaza wa wasafa shirak al-insihab bi anahu khutua shuja'a wa min al-mutawaq'a ann yahuth shirak al-esreliyeen 'la al-qiyam al-mazid min al-khutuwat lil-muhafada 'la al-daf' bi etejah al-salam fi al-sharq al-awsat wa yatawaq' ann yastakhdim sharun al-ziyara li-emitdah al-hukuma al-faransiya lil khutwat alati etakhathatha li mukafahat mu'anat al-samiya.

In the English ST, the verb *expected* is repeated three times while the sense of 'retreat' is expressed three times using three different lexical items: *pullout*, *withdrawal* and *moves*. Apparently, the repetition is a discourse strategy adopted by the writer of the ST. A similar kind of repetition is found in the Arabic text. For example in the determiner phrases and prepositional phrases: المتوقع (*al-mitawaq'a*) 'the expected', الانسحاب (*al-ensihab*) 'the withdrawal', الخطوات (*al-khitiwat*) 'the steps' and للخطوات (*lil-khitwat*) 'for steps'.

Now, we will consider the next example (24) and its Arabic version with transliteration below:

24. (a) ST: Iraq tribes 'taking on al-Qaeda'

A group of Sunni tribal chiefs in Iraq say they have caught more than 100 al-Qaeda members in recent months. The tribal chiefs in the Iraqi province of Anbar joined forces in September

in an attempt to defeat al-Qaeda. They set the salvation Council for Anbar and claim to have reduced the numbers of weapons and foreign fighters coming into the area.

”عشائر سنية عراقية تتصدى للقاعدة (b)

قالت مجموعة من زعماء العشائر السنية في العراق انهم القوا القبض على اكثر من 1000 من اعضاء القاعدة في الاشهر الاخيرة و كان زعماء العشائر في محافظة الانبار قد ضموا قواتهم في سبتمبر/ايلول الماضي في محاولة للقضاء على تنظيم القاعدة. واسست هذه العشائر مجلس انقاذ الانبار و زعمت انها . ساهمت في خفض عدد الاسلحة و المقاتلين الاجانب في هذه المنطقة

(c) Trs: 'ashaer suneeya eraqiya "tatasada lil-qa'ada"

Qalat majmu'a min zu'amaa al-'ashaer al-suneeyah fi al-erag anahum alqaw al-qabd'la akthar min 1000 min a'daa al-qa'eda fi al-ashhur al-akhira. wa kana zu'ama al-'ashaer fi muhafadat al-anbar qad damu quwatahum fi septambar / aylul al-mdi fi muhawalat lil-qada 'la tandem al-qa'eda wa asasat hathihi al-'ashaer majlis enqath al-anbar wa za'amat enaha sahamat fi khefd 'adad al-asliha wa al-muqatileen al-ajaneb fi hathih al-mantaqa.

In the English ST, the noun phrase *tribal chiefs* are repeated twice; so is the pronominal *they*. A similar repetitive strategy is observed in the Arabic TT: زعماء العشائر السنية (*zu'amaa al-'ashaer al-suneeya*) 'Sunni tribal chiefs' and زعماء العشائر ” (*zu'amaa al-'ashaer*) 'tribal chiefs'. In Ghazala's (1995) view, some of

these phrases which are used as discourse strategies are sometimes unnecessarily repeated in the TT.

Stylistics due to Punctuation Marks.

Ghazala (1995) notes that punctuation marks have important stylistic functions and caution English-Arabic translators to pay attention to them as they may have some semantic implications. In this section we will consider the punctuation marks written in two cases of the English ST and the TT using data in (25) and (26):

25. (a) ST Maliki endorsed as new Iraqi PM.

They also gave the post of Parliament speaker to Mahmood al Mashhadani , a sunni Arab

(b) كما اختير محمود المشهداني وهو سني رئيس للجمعية الوطنية

(c) Trs: Kama ukhteera mahmood al mashhadani wa hua suni raees lil jam'eeyah al wataneeyah.

26. (a) ST: *Gaza settlers face tough decision*

Leader Ismail Haniya said: “ Hamas confirms it is committed to armed resistance, it is our strategic choice until the end of the occupation of our land.”

(b) تاهب امني في غزة قبيل الانسحاب الاسرائيلي
و قال القيادي في حماس اسماعيل هنية: “
حماس تؤكد التزامها بالقتال المسلح, هذا خيارنا
”الاستراتيجي حتي نهاية احتلال اراضي

(c) taahub amni fi gaza qubeil al-insihab al-israeli

Wa qala al-qeeyadi fi hamas esma'eel haneeya: “hamas tuakid eltizamaha bi al-qital al-musalah, hatha khyarana al-estitratigi hata nihayat ehtilal aradeeina”

In (25)(a) a comma has been used in the ST to mark a following clause without using a syntactic connective. Without the comma in place, a relative pronoun is necessary. Its corresponding Arab text in (25)(b) ignores the comma. As for (25)(a), the ST contains a colon and two inverted commas. As found in the data in (25)(b), the translator has respected the ST punctuation marks in his/her translation into Arabic. Hence, it is observed that punctuation marks are used inconsistently in the TT.

CONCLUSION

This paper examines 25 English ST. The structures of the English texts and their corresponding Arab translations are compared using various techniques: phrase markers in tree configuration, in linear structures (label-bracketing) and some narrative descriptions. To facilitate our description, I choose to work within several headings such as borrowing, calque, literal, transposition, adaptation, modulation and equivalence (paraphrase). In summary, in the process of translation, significantly there have been many stylistic changes. Most of these changes are within the realm of syntax such as sentences, clauses and phrases. Some other stylistic changes are due to morphological functions such as tenses and verb morphology. Still other changes are due to discourse strategies such as repetition of

lexical elements, clausal connectives and punctuation marks. English terms that are found unable to be adopted (or restated in a transliterated form) or for reason of the absence of any suitable equivalence in Arabic are found to be changed into different styles according to the purposes of the TT and expressed in ways that are appropriate with Arabic grammar, cultural and sociolinguistic situations. They are expressed as a modulation, a variation of the form of a message that is obtained by a change in point of view; an adaptation, involving changing the cultural reference when a situation in the source culture does not exist in the target culture; a paraphrase, providing meaning through simplification; or as a literal translation.

Finally, there seems to be no syntactic borrowing from English to Arabic. In the area of morphology, there seems to be some evidence of stylistic change that are prompted by lexical borrowing from Arabic to English and then re-borrowing to Arabic. Absence of parallel patterns in the tenses, different uses of the articles as well as differences in the nature of verb morphology contribute greatly to the style of the TT. In addition, discourse elements such as the metaphors, the direct/indirect expressions and the connectives are found to have some influence in the style of the TT. Whenever there is an absence of linguistic equivalence, the translator seems to want to circumvent it by way of either modulation, adaptation, paraphrase or even literal translation yielding various stylistic changes in the TT.

Overall, in expressing the political news from English BBC texts, the translator favors expressing them in a style that is in keeping with MSA. Informal or vulgar style of the translated messages is not found. My presentation of linguistic stylistic changes has employed the X' Theory of Culicover (1997). Another approach to a linguistics stylistic study is a narrative descriptive approach or perhaps using a different syntactic notation. Such study will certainly complement the findings of this paper.

REFERENCES

- Bell, R. (1998). *Psycholinguistic/Cognitive Approaches*, in M. Baker (ed.).
- Boase-Beier, J. (2006). *Stylistic Approaches to Translation*. Manchester: St Jerome Publishing
- Culicover, Peter. (1997). *Principles and Parameters: An Introduction to Syntactic Theory*. New York: Oxford: Oxford University Press. U.S.A.
- Chapman, R. (2008), *The Language of English Literature*. London: Edward Arnold.
- Crystal, D. (1992). *An Encyclopedia Dictionary*. London: Longman.
- Enkvist, N. E. (1973). *Linguistic Stylistics*. The Hague: Mouton Press.
- Hatim, B. (1997). *Communication across Cultures: Translation Theory and Contrastive Text Linguistics*. Exeter: University of Exeter Press, U.K.
- Haynes, J. (1989). *Introducing Stylistics*. London: Butler and Tonner Ltd
- Ghazala, Hasan. (1995). *Translation as Problems and Solutions: A Coursebook for University Students and Trainee Translators*. Beirut: Dar wa Maktabat Al-Hilal. Lebanon.

- Gutt, E.-A. (2000). *Translation and Relevance. 2nd edition*. Manchester: St Jerome Publishing.
- Iser, W. (1974). *The Implied Reader: Patterns of Communication in Prose Fiction from Bunyan to Beckett*. Baltimore: Johns Hopkins University Press.
- Lawal, A. (1997). Aspects of A Stylistics Theory and the Implications for Practical Criticism. In A. Lawal (Eds.), *Stylistics in Theory and Practice*. (pp.25-31) Ilorin: Haytee Press.
- Leech, G., & Short, M. (2007). *Style in Fiction: A Linguistic Introduction to English Fictional Prose, 2nd edition*. London: Longman.
- Leech, G., & Short, M. (1981). *Style in Fiction: A linguistic Introduction to English Fictional Prose*. London and New York: Longman.
- Malmjaer. (1981). *The Linguistic Encyclopaedia*. London: Longman
- Nnadi, ch., (2010). *A Linguistic Stylistic Analysis of Chukwuemeka Ie's Novels*, (Unpublished Ph.D thesis). University of Jos.
- Slobin, D. I. (2003). Language and Thought Online: Cognitive Consequences of Linguistic Relativity', in D. Gentner and S. Gocklin-Meadow (eds.), *Language in the Mind: Advances in the Study of Language and Thought*. Cambridge, Massachusetts:MIT Press, 157-192.
- Stockwell, P. (2002). *Cognitive Poetics: An Introduction*. London: Routledge.
- Scott, C. (2000). *Translating Baudelaire*. Exeter: University of Exeter Press.
- Vinay, J. P., & Darbelnet, J. (1995). *Comparative Stylistic of French and English :A Methodology for Translation*. Amsterdam :John Benjamins, The Netherlands
- Wales, K. (2001). *A Dictionary of Stylistics*. England: Pearson Education.
- Widdowson, A. (1975). *Stylistics and the Teaching of Literature*. England: Longman.Linguistics Stylistics

APPENDIX

List of Abbreviations used in the Analysis

A'	=	Adjective Phrase
A	=	Adjective
Aux	=	Auxilliary
BBC	=	British Broadcasting
BT	=	Back
Conj	=	Conjunction
CONJ'	=	Conjunction
COMP	=	Complementation
Comp	=	Complementizer
CP	=	Complementizer Phrase
C'	=	Complement
D'	=	Determiner Phrase
D	=	Determiner
F	=	Functional
I	=	Inflection
IP	=	Inflectional Phrase (sentence)
Mod.	=	Modal
MSA	=	Modern Standard Arabic.
N'	=	Nominal Compound
N	=	Noun
NEG	=	Negation
NP	=	Noun Phrase
Obj	=	Object
OSV	=	Object Subject Verb
P'	=	Prepositional Phrase
Pro.	=	Pronoun
S	=	Subject
SL	=	Source Language
SLT	=	Standard Language Text
Spec.	=	Specifier
SVO	=	Subject-Verb-Object
V'	=	Verb Phrase (Predicate)
V	=	Verb



Entrepreneurial Leadership Behaviour among School Principals: Perspectives from Malaysian Secondary School Teachers

Zaidatul Akmaliah Lope Pihie, Afsaneh Bagheri* and Soaib Asimiran

Faculty of Educational Studies, Universiti Putra Malaysia, 43400 Serdang, Selangor, Malaysia

ABSTRACT

Entrepreneurial leadership is a particular leadership behaviour that enables leaders to face the challenges of their tasks and roles in the current environment of organisations. Education scholars believe that this type of leadership empowers educational leaders to meet the diverse needs of students as well as the ever-changing demands of the school environment. However, many questions have been raised on how to measure entrepreneurial leadership behaviour in educational settings and in particular among school principals. The main purpose of this study was to determine Malaysian secondary school principals' entrepreneurial leadership behaviour through teachers' perspectives using the Entrepreneurial Leadership Questionnaire. A total sample of 300 school teachers were asked to rate the frequency of entrepreneurial leadership behaviour in their school principals. The data was analysed using Structural Equation Modelling. The results indicated that the questionnaire is highly valid and reliable to measure school principals' entrepreneurial leadership behaviour. Furthermore, entrepreneurial leadership is a multi-dimensional construct that can be explained by five leadership behaviours including general entrepreneurial leader behaviour, explorer behaviour, miner behaviour, accelerator behaviour and integrator behaviour. Implications of the findings are also discussed in this paper.

Keywords: Entrepreneurial leadership, leadership behaviour, school principals, school teachers, Malaysia

ARTICLE INFO

Article history:

Received: 30 November 2012

Accepted: 3 March 2014

E-mail addresses:

zalp@upm.edu.my (Zaidatul Akmaliah Lope Pihie),

af.bagheri@ut.ac.ir (Afsaneh Bagheri),

soaib@upm.edu.my (Soaib Asimiran)

* Corresponding author

INTRODUCTION

Entrepreneurial leadership has been defined as a particular type of leadership behaviour that enables leaders to face the increasing challenges of their tasks and roles in

the current organisational environment (Hentschke, 2009; Gupta *et al.*, 2004). This leadership style assists leaders in directing people to achieve their vision and overcoming obstacles in different stages of organisational growth as well as the challenges and crises found in the organisation environment (Chen, 2007; Swiercz & Lydon, 2002). Entrepreneurial leaders, therefore, can more successfully recognise new opportunities to improve their organisation's performance (Chen, 2007; Okudan & Rzasa, 2006; Gupta *et al.*, 2004). The fundamental impact of entrepreneurial leadership behaviour on improving leadership effectiveness and organisational performance has received increasing attention by education scholars in order to improve various aspects of education and specifically school leadership (Xaba & Malindi, 2010; Berglund & Holmgren, 2006; Collins *et al.*, 2004; Eyal, & Kark, 2004; Eyal & Inbar, 2003).

Yet, there has been ongoing debate on how to measure entrepreneurial leadership behaviour among educational leaders (Yusof, 2009). The majority of previous studies on entrepreneurial leadership have been conducted qualitatively (e.g., Leitch *et al.*, in press; Kempster & Cope, 2010; Xaba & Malindi, 2010; Gupta *et al.*, 2004). Furthermore, prior research only measured limited aspects of educational leaders' entrepreneurial leadership behaviour (Yusof, 2009). In response, this study aims to measure different dimensions of principals' entrepreneurial leadership behaviour through teachers' perspectives. This paper

describes the differences and similarities between entrepreneurial leadership and other leadership behaviour. It highlights the advantages of entrepreneurial leadership for school leadership and performance improvement and specifies the organisational and environmental demands that necessitate application of entrepreneurial leadership principles by school leaders. Subsequently, the research method and measurement model used for entrepreneurial leadership are presented. Finally, the study's findings are discussed with regard to the implications for developing entrepreneurial leadership research and practice in schools.

How Is Entrepreneurial Leadership Different from Other Types of Leadership Behaviour?

Entrepreneurship scholars have highlighted the differences between entrepreneurial leaders and other leaders in three domains. First, entrepreneurial leaders possess inherent characteristics that differentiate them from other leaders and motivate and enable them to enter the challenging process of leading entrepreneurial activities (Chen, 2007; Kuratko, 2007; Fernald *et al.*, 2005; Gupta *et al.*, 2004; Nicholson, 1998). Entrepreneurial characteristics which are most referred to with respect to both entrepreneurial leaders and organisations are innovativeness, proactiveness and risk taking (Chen, 2007; Kuratko, 2007; Gupta *et al.*, 2004; Covin & Slevin, 1991). Innovativeness is the ability and tendency of entrepreneurial leaders to think creatively and develop novel and practical ideas for improving the performance of the organisation, using

resources more effectively and solving problems constructively (Chen, 2007; Rae, 2007; Gupta *et al.*, 2004). Proactiveness is the entrepreneurial leaders' capability to envision and lead toward the future rather than passively waiting to be affected and challenged by it. This trait enables entrepreneurial leaders to recognise new opportunities for entrepreneurial activities and take action to exploit the opportunities (Kuratko *et al.*, 2007; Kuratko & Hornsby, 1999). It highly enhances entrepreneurial leaders' creativity, desire and intention to initiate entrepreneurial activities and their perseverance in their vision attainment (Zampetakis, 2008; Kuratko *et al.*, 2007; Kickul & Gundry, 2002). Finally, entrepreneurial leaders have a strong tendency towards risk taking despite the presence of costly failures (Chen, 2007; Zhao *et al.*, 2005; Mueller & Thomas, 2000). However, having the innate characteristics of an entrepreneurial leader is not sufficient to be successful in leading entrepreneurial activities (Gupta *et al.*, 2004; Swiercz & Lydon, 2002).

Second, entrepreneurial leaders lead in highly complex and demanding economic and competitive situations (Hentschke, 2009; Fernald *et al.*, 2005; Cogliser & Brigham, 2004; Vecchio, 2003). These leaders start entrepreneurial activities from the very beginning and in highly turbulent and uncertain environments (Gupta *et al.*, 2004; Swiercz & Lydon, 2002). They are competent in overcoming the challenges and crises in the environment (Vecchio, 2003; Swiercz & Lydon, 2002). Finally, the process

of leaders' influence on followers to enact their vision is different for entrepreneurial leaders because they need to mobilise and direct a group of competent and competitive people and capitalise on their creativity and innovativeness in order to maintain the sustainability of their entrepreneurial activities (Chen, 2007; Gupta *et al.*, 2004). Various factors such as personal characteristics, organisational and task performance demands and environmental factors affect the process of influencing followers that makes leadership as a highly challenging role for entrepreneurial leaders (Leitch *et al.*, in press; Kempster & Cope, 2010; Kempster, 2009, 2006).

Despite these differences, however, there are also key similarities between entrepreneurial leadership and the terms that construct the concept: entrepreneurship and leadership. For example, Fernald *et al.* (2005) argue that most of the tasks and roles of entrepreneurs are leadership-based and Cogliser and Brigham (2004) emphasise that organisational leaders require entrepreneurial competencies to deal with the difficulties and impediments in the environment of current organisations. Specifically, scholars argue that entrepreneurial leaders' competencies in anticipating the future, exploring new opportunities, creating novel ideas and providing an environment for staff that encourages and supports generating and implementing new ideas help organisational leaders face problems and achieve their vision (Burns, 2005; Gupta *et al.*, 2004). Through an integrating approach to leadership and entrepreneurship, Roomi

and Harrison (2011) have recently defined entrepreneurial leadership as “having and communicating the vision to engage teams to identify, develop and take advantage of opportunity in order to gain competitive advantage” (p. 2). Thornberry (2006) combined three types of leadership styles including transformational, transactional and charismatic leadership to better explain entrepreneurial leadership behaviour both at personal and organisational levels. He emphasised that entrepreneurial leaders need to be innovative and proactive and need to take risks and practice entrepreneurial approaches in performing their leadership tasks and roles. Although previous research does shed some light on entrepreneurial leadership as an emerging paradigm, there is still limited knowledge on how educational leaders can apply such leadership to enhance their leadership effectiveness and consequently, improve their school performance (Xaba & Malindi, 2010; Berglund & Holmgren, 2006). The next section of this paper discusses the benefits of entrepreneurial leadership for school principals and the environmental constraints that compel principals to perform their tasks like an entrepreneurial leader.

How Does Entrepreneurial Leadership Help School Principals?

Scholars argue that entrepreneurial leadership can assist school principals to meet the diverse needs of students and ever-changing demands of the school environment in three important ways. First, entrepreneurship in general and entrepreneurial leadership in

particular is a way of thinking and lifestyle rather than merely establishing and leading a new business (Kuratko, 2007; Klein & Bullock, 2006; Hytti & O’Gorman, 2004). In this respect, entrepreneurial leadership principles and approaches can be applied in all aspects of education including school leadership through influencing the leaders’ behaviour and task performance as well as their capability to look above and beyond current school status and explore new opportunities for school improvement (Berglund & Holmgren, 2006; Eyal & Kark, 2004). By acquiring and practising entrepreneurial leadership approaches in their school leadership task performances, principals can improve their school effectiveness and prepare an appropriate environment that facilitates teaching and learning (Mohd Sahandari *et al.*, 2009). Second, researchers highlight the advantages of entrepreneurial leadership for organisational performance improvement and, specifically, for creating the required changes and innovations in the organisation (Holt *et al.*, 2007, Kuratko *et al.*, 2007; Gupta *et al.*, 2004; Swiercz & Lydon, 2002; Kuratko & Hornsby, 1999). In this sense, educational leaders apply entrepreneurial leadership to enhance organisational innovation in educational settings (Yusof, 2009). To be specific, school principals implement entrepreneurial leadership approaches such as developing new ideas and exploring opportunities to improve schools’ educational environment in order to foster the process of required changes and innovations in the school performance (Eyal

& Kark, 2004; Eyal & Inbar, 2003). Previous research emphasised the influential impact of applying entrepreneurial leadership on different aspects of performance improvement in educational settings (Xaba & Malindi, 2010; Yusof, 2009). For example, findings of Yusof's (2009) research suggested a significant relationship between entrepreneurial leadership behaviour of Malaysian research universities' leaders and organisational innovations in the universities.

Furthermore, educational leaders can gain great benefits from entrepreneurial leadership approaches and principles in dealing with various challenges and constraints imposed by the educational environments (Xaba & Malindi, 2010). Hentschke (2009) emphasised that school principals are facing the challenge of improving the quality of education for larger populations of students at public schools and exploring creative and innovative ways to increase school resources. In addition, rapid changes in the environment coupled with a variety of factors that affect school performance and the urgent need for equipping students for their highly competitive future add to the complexities and challenges that school principals are required to deal with (Morris *et al.*, 2007; Eyal & Kark, 2004; Eyal & Inbar, 2003). In order to overcome these challenges and difficulties, school principals need to purposefully practise entrepreneurial leadership (Xaba & Malindi, 2010).

How Can We Measure Entrepreneurial Leadership?

Previous studies on entrepreneurial leadership have been predominantly conducted through qualitative methods of inquiry (Leitch *et al.*, in press; Kempster & Cope, 2010; Xaba & Malindi, 2010; Swiercz & Lydon, 2002). In fact, quantitative research that measures different dimensions of the construct is scarce specifically in the educational contexts. Prior research has measured limited aspects of educational leaders' entrepreneurial leadership behaviour (Yusof, 2009). This is partially because entrepreneurial leadership as a distinctive type of leadership behaviour has recently emerged in the literature and the theoretical and conceptual foundations of the notion is in the early stages of development (Leitch *et al.*, in press; Kempster & Cope, 2010; Gupta *et al.*, 2004; Swiercz & Lydon, 2002). Moreover, there is no well-established measurement model for the concept (Thornberry, 2006). Eyal and Inbar (2003) developed an inventory to measure principals' entrepreneurial approaches at elementary schools. The inventory estimates the extent of innovations and initiations implemented by the principals and the changes the innovations created in the school performance. The inventory only contains principals' innovativeness and proactiveness and does not include risk taking for two important reasons as Eyal and Inbar highlighted. First, according to Lumpkin and Dess (1996), risk taking does not have a linear function in organisations.

Second, principals' freedom to take risks is limited in centralised education systems. The inventory consisted of 14 items on how school principals practise entrepreneurial leadership approaches in leading their schools.

More recently, Thornberry (2006) integrated transformational, transactional and charismatic leadership to develop a theoretical foundation for entrepreneurial leadership that explains such leadership behaviour at both personal and organisational levels. Thornberry proposed a multi-dimensional framework that measured how entrepreneurial leaders use their innovativeness, proactiveness and risk taking capacities to perform their tasks. He developed the Entrepreneurial Leadership Questionnaire (ELQ), which assesses organisational leaders' entrepreneurial leadership behaviour using 50 items. The questionnaire measures entrepreneurial leadership behaviour in five dimensions including general entrepreneurial leader behaviour, explorer behaviour, miner behaviour, accelerator behaviour and integrator behaviour. General entrepreneurial behaviour reflects one's ability to apply an entrepreneurial approach at work and provide an encouraging and supportive environment for staff to be innovative and take risks in performing their tasks and persist in the face of problems and quickly change the strategies that might not be effective. Explorer behaviour is the entrepreneurial leaders' action in discovering new opportunities for the organisation's development, developing

creative strategies for the organisation's performance improvement and envisioning an innovative future for the organisation. Miner behaviour reflects the entrepreneurial leaders' action in performing leadership tasks creatively, applying innovative approaches to solve problems and considering all of the organisation's stakeholders when making decisions.

Accelerator behaviour includes challenging staff for creative thinking, encouraging them to improve their task performances through innovative approaches and creating a supportive environment for them to try new approaches. Finally, integrator behaviour is reflected when the organisation's vision is communicated to the staff, encouraging them to engage in entrepreneurial thinking as well as providing money for innovative ideas. Despite its merits in measuring different aspects of entrepreneurial leadership in established organisations, there is limited empirical research that has applied the questionnaire to assess entrepreneurial leadership behaviours particularly in educational contexts (Yusof, 2009). Using the ELQ (Thornberry, 2006), Yusof (2009) examined academic leaders' entrepreneurial leadership behaviour in four Malaysian research universities through academicians' (professors, associate professors and lecturers) perspectives. The findings of the study indicated the questionnaire was valid and reliable to measure entrepreneurial leadership behaviour in Malaysian educational contexts. However, the research only focused on one dimension of entrepreneurial leadership

behaviour (general entrepreneurial leadership behaviour) and did not examine the other four aspects of entrepreneurial leadership behaviour. Drawing upon Thornberry's (2006) conceptual framework and using the ELQ, this study attempted to address two important questions. First, is the ELQ valid to measure Malaysian secondary school principals' entrepreneurial leadership behaviour and second, is the principals' entrepreneurial leadership behaviour a multi-dimensional concept consisting of general entrepreneurial leader behaviour, explorer behaviour, miner behaviour, accelerator behaviour and integrator behaviour?

METHOD

Participants

This paper reports the first phase of a research project on entrepreneurial leadership at Malaysian secondary schools. The population for this study was the teachers from secondary schools in the district of Hulu Langat, Selangor in West Malaysia. Three hundred teachers were selected from six public secondary schools as a sample for the study. The schools were selected based on the criteria that the principals must have more than two years of experience in leading that school. This criterion was used to ensure that the teachers had enough knowledge about the principals' leadership practices at the school. Fifty teachers were randomly selected from each school. Only public secondary schools were involved in this study because according to Eyal and Kark (2004) and Eyal and Inbar (2003), school

principals' entrepreneurial orientation varies among different education levels due to the extent of the principals' autonomy, the school's organisational bureaucracy in the education system and the variety of students and their enrolling subjects. The participants were chosen from both daily academic (n = 262, 87%) and high performing schools (n = 38, 12%). The majority of the teachers were of the age 41 to 50 (42%) years. Most of the teachers were female (n = 267; 88.4%) with 8 to 33 (n = 271, 90%) years of teaching experience.

Entrepreneurial Leadership Measure

The Entrepreneurial Leadership Questionnaire (ELQ) developed by Thornberry (2006) was employed to measure school principals' entrepreneurial leadership behaviours. The questionnaire consists of 50 items on five dimensions of entrepreneurial leadership including general entrepreneurial leader behaviour (GELB), explorer behaviour (EXPB), miner behaviour (MINB), accelerator behaviour (ACCB) and integrator behaviour (INTB). The questionnaire measures GELB by nine items, EXPB by nine items, MINB by seven items, ACCB by 11 items and INTB by 14 items (refer to Appendix A). Some words in the questionnaire were changed such as the word business to school in order to improve their validity in measuring the entrepreneurial leadership behaviour of school principals due to the fact that the instrument originated within the entrepreneurship and business domains. Subsequently, the questionnaire was

translated from English to Malay and back to English by two bilingual experts (two of the authors) to ensure the accuracy of the translated questionnaire.

To ensure the appropriateness of the translated questionnaire, the experts tested the questionnaire against four criteria (Pan & Fond, 2010). First, each item was checked to ensure none of the concepts had been deleted. Second, each item was tested for the accuracy and appropriateness of the vocabulary, grammar and usage of conventions. Third, each item was tested to see if it expressed the same concept as in English. Finally, each item was checked to ensure that it did not contain any concept unfamiliar to the participants. The questionnaire also included the teachers' background information such as age, gender, years of teaching experience, type of school and number of enrolling students. The participants were asked to indicate their degree of agreement with the items of the questionnaire on a 5-point Likert scale anchored from 1 (strongly disagree) to 5 (strongly agree).

Data Collection

Participation in this study was entirely voluntary and all questionnaires were administered completed anonymously. Data collection was conducted during the academic year of 2011-2012. Permission to conduct the research was obtained from the Ministry of Education and the school principals by sending them a packet that included the research questionnaire and

a cover letter which briefly explained the objectives of the study and described how the research would be of benefit to the schools and education on the whole.

Data Analysis

To measure different dimensions of entrepreneurial leadership behaviour and specify the best items that represent the five dimensions of the construct, Structural Equation Modelling (SEM) and AMOS Version 20 were employed. The technique of Hair *et al.* (2010) was also adopted for the study's data analysis. First, the structure of the items and loadings of the factors to each of the five constructs in the model (GELB, EXPB, MINB, ACCB and INTB) were assessed by performing a Confirmatory Factor Analysis (CFA) for each construct. This step helped in eliminating the items with low loadings (<.60) to the factors. Of the nine items measuring GELB, two items were deleted (GEL4 and GEL2). Three items from EXPB (EXP8, EXP3 and EXP1), two items from ACCB (ACC11 and ACC10) and one item from INTB (INT14) were also deleted due to their low loadings to the factors. Second, the measurement model fit indices for the individual constructs including, GELB, EXPB, ACCB and INTB were examined to ensure the relationships among the latent and observed variables were supported by the data. Table 1 shows means, standard deviations and correlations for all the constructs in the model. The correlations among all the study constructs were significant. This indicates the

theoretical and conceptual interrelationships which are parallel among the constructs in the measurement model (Schreiber *et al.*, 2006).

FINDINGS

To examine the validity and reliability of the ELQ, the measurement model with all of the five constructs was developed and the items with high factor loadings included in one measurement model. Table 2 presents the means, standard deviations, factor loadings (FLs) and Cronbach’s *a* obtained for all the items in the ELQ before deleting the items with low loadings. The Cronbach’s *a* showed that all of the constructs scored higher than 0.80 indicating that the questionnaire was highly reliable to measure the dimensions of school principals’ entrepreneurial leadership behaviour. Analysis of the measurement model developed with all the study constructs and items indicated that the model does not fit the data because the goodness-of-fit indices were less than 0.90 and RMSEA was higher than the 0.05 threshold (Byrne, 2010) [Chi-Square ($\chi^2=3392.34$); Degree of Freedom (DF =

979); $p = 000$; goodness-of-fit index (GFI = .58); adjusted goodness-of-fit index (AGFI = .54); comparative fit index (CFI = .79); Bentler-Bone normed fit index (NFI = .73); Tucker-Lewis index (TLI = .78); and root-mean square error of approximation (RMSEA = .091)]. In order to improve the goodness-of-fit indices, the items with high correlations were deleted ($M.I > 20$).

In this step, four items from GELB (GEL8, GEL1, GEL 5 and GEL3) were deleted one at a time. These items were related to principals’ behaviour in taking risks and dealing with school organisational rules and bureaucracy. Two items from EXPB (EXP2 and EXP4) were also eliminated. These items measured principals’ behaviour in highlighting the weaknesses of competitors and creating new ways to grow the school. Of the items on MINB (MIN3, MIN1, MIN2 and MIN4), four were deleted. These items estimated principals’ behaviour in communicating school improvement goals with upper managers, searching for creative ways to use resources, considering school stakeholders when making decisions, and challenging school members to creatively improve school effectiveness.

TABLE 1
Means, Standard Deviations and Correlations of Study Constructs

Variables	Mean	SD	1	2	3	4	5
General entrepreneurial leadership behaviour (GELB)	29.50	5.49	1				
Explorer behaviour (EXPB)	33.17	6.66	.74**	1			
Miner behaviour (MINB)	26.25	4.68	.79**	.82**	1		
Accelerator behaviour (ACCB)	39.21	7.39	.84**	.84**	.84**	1	
Integrator behaviour (INTB)	49.72	9.93	.82**	.80**	.83**	.84**	1

** Indicate Correlation is significant at the 0.01 level (2-tailed).

TABLE 2
Mean, Standard Deviation and Factor Loadings for Entrepreneurial Leadership Questionnaire Items

Constructs	Items	Mean	SD	FLs	a	Constructs	Items	Mean	SD	FLs	a		
General entrepreneurial leadership behaviour (GELB)	GEL1	3.62	1.0	.56	.93	Accelerator behaviour (ACCB)	ACC1	3.50	.97	.70	.91		
	GEL2	3.10	1.0	.43			ACC2	3.74	.90	.77			
	GEL3	3.57	.96	.78			ACC3	3.25	1.11	.52			
	GEL4	1.68	1.0	.07			ACC4	3.40	.93	.57			
	GEL5	3.16	.97	.62			ACC5	3.69	.89	.66			
	GEL6	3.56	.88	.78			ACC6	3.63	.84	.67			
	GEL7	3.58	.85	.68			ACC7	3.64	.78	.79			
	GEL8	3.49	.93	.50			ACC8	3.68	.79	.72			
	GEL9	3.70	.90	.79			ACC9	3.55	.84	.66			
Explorer behaviour (EXPB)	EXP1	3.92	.91	.71	.93		Integrator behaviour (INTB)	ACC10	3.61	.96		.85	.94
	EXP2	3.65	.94	.72				ACC11	3.48	1.01		.80	
	EXP3	3.82	.93	.73		INT1		3.74	.90	.63			
	EXP4	3.86	.86	.84		INT2		3.20	.99	.59			
	EXP5	3.60	.89	.84		INT3		3.64	.94	.82			
	EXP6	3.52	.87	.81		INT4		3.59	.93	.79			
	EXP7	3.68	.87	.79		INT5		3.69	.91	.84			
	EXP8	3.54	.94	.78		INT6		3.16	.98	.74			
	EXP9	3.54	.95	.81		INT7		3.60	.92	.81			
Miner behaviour (MINB)	MIN1	3.81	.92	.74	.81	INT8		3.59	1.00	.80			
	MIN2	3.76	.87	.79		INT9		3.74	.87	.79			
	MIN3	3.77	.89	.73		INT10		3.78	.87	.74			
	MIN4	3.68	.85	.61		INT11		3.72	.83	.84			
	MIN5	3.71	.83	.69		INT12		3.81	.82	.81			
	MIN6	3.76	.82	.66		INT13	3.32	.93	.80				
	MIN7	3.74	.92	.68		INT14	3.08	1.01	.59				

The five items eliminated from ACCB (ACC3, ACC7, ACC4, ACC1 and ACC2) were related to the principals' behaviour in creating an encouraging and supportive environment for school members to be creative and take action to implement their new educational ideas. Finally, eight items from INTB (INT1, INT2, INT5, INT4, INT6, INT13, INT3 and INT8) were also deleted. These items encompassed the principals' interpersonal behaviour such as communicating an improvement vision for school, social networking, building an innovative culture in school and encouraging

entrepreneurial thinking and risk taking. Fig.1 depicts the measurement model and standardised regression weights for the items.

Analysis of the measurement model developed with 18 remaining items indicated that the model fits the data well because all of the goodness-of-fit indices were higher than 0.90 and RMSEA was less than the 0.05 threshold (Hair *et al.*, 2010) [$\chi^2 = 199.34$; $DF = 125$; $p = 000$; $GFI = .93$; $AGFI = .90$; $CFI = .97$; $NFI = .98$; $TLI = .97$; and $RMSEA = .045$]. Table 3 shows means, standard deviations, factor

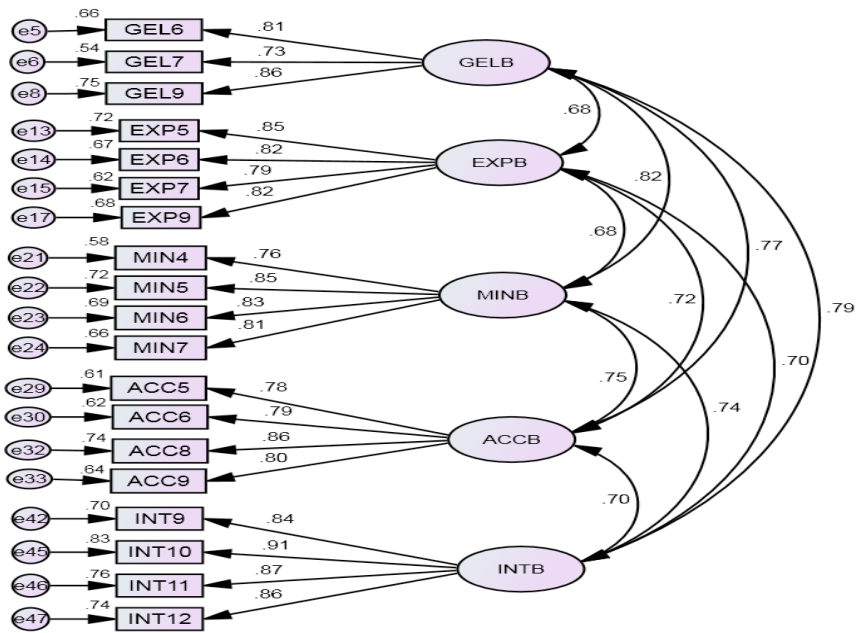

Chi-Square=244.598 DF=142
 p=.000 GFI=.922 AGFI=.896
 CFI=.976 NFI=.945 TLI=.971
 RMSEA=.049

Fig.1: Measurement model for entrepreneurial leadership with standardised regression weights

loadings C.R, AVE, MSV and ASV for the five constructs and 18 items included in the measurement model. All of the items in the final measurement model had high factor loadings (FLs > .70). The composite reliability indices (C.R) obtained for the study constructs were also greater than the 0.7 threshold, which confirms the high reliability of the constructs. Furthermore, all of the study constructs scored an average variance extracted (AVE), the portion of the construct variance explained by its factors, that was higher than the 0.5 thresholds, indicating a high convergent validity for all

of the study constructs. The higher scores of C.R compared with AVE also supports the high convergent validity of the scale items.

To be specific, GELB is best explained by three items that measure behaviour of school principals in identifying different approaches to overcome obstacles, demonstrating an entrepreneurial orientation at work and listening to others to do things differently. EXPB is best explained by four items on motivating teachers to think of innovative ways, selling new educational ideas to upper managers, sharing the school status with teachers and selecting the

TABLE 3

Factor loadings, C.R, AVE, MSV and ASV for entrepreneurial leadership questionnaire items in the study measurement model

Constructs	Items	Factor loadings	C.R	AVE	MSV	ASV
General entrepreneurial leadership behaviour (GELB)	GEL6	.81	0.84	0.64	0.68	0.59
	GEL7	.72				
	GEL9	.89				
Explorer behaviour (EXPB)	EXP5	.84	0.89	0.67	0.51	0.48
	EXP6	.81				
	EXP7	.78				
	EXP9	.82				
Miner behaviour (MINB)	MIN5	.85	0.86	0.68	0.68	0.56
	MIN6	.81				
	MIN7	.81				
Accelerator behaviour (ACCB)	ACC5	.78	0.88	0.65	0.59	0.53
	ACC6	.78				
	ACC8	.86				
	ACC9	.79				
Integrator behaviour (INTB)	INT9	.83	0.92	0.75	0.63	0.54
	INT10	.91				
	INT11	.87				
	INT12	.85				

right people to capture new opportunities. MINB comprised three items on analysing workflows, resources and processes to improve teachers' performance, expecting the teachers to solve cross-school problems and supporting them to fight for changes and improvement. ACCB is best explained by four items on behaviour of school principals in encouraging teachers to learn new skills, changing directions when results are not being achieved, engaging them in innovative thinking and allotting time to help them find ways to improve school performance. Finally, INTB included four items on sharing information on new educational trends and methods, encouraging school improvement suggestions, taking action in implementing the suggestions, keeping school focused

on its core strategy and supporting new educational initiatives.

To ensure a construct is best explained by its own items and the items are not highly correlated with items in other constructs, the discriminant validity of the constructs was also measured by Maximum Shared Squared Variance (MSV) and Average Shared Squared Variance (ASV) (Hair *et al.*, 2010; Kline, 2010). Analysis of the indices obtained in this study indicated that all of the MSV and ASV scores were less than AVE scores except for GELB and MINB. MSV for GELB was higher than AVE ($0.68 > 0.64$) and MSV for MINB was equal to AVE (0.68). This implies that all of the items in the scale had the highest loadings to their own constructs and only

some of the items on GELB and MINB were highly correlated with the items on other constructs in the measurement model. This needs to be considered in order to improve the discriminant validity of the ELQ.

The findings highlight the importance of applying different dimensions of entrepreneurial leadership behavior in order to approach school leadership like an entrepreneurial leader and improve school performance.

DISCUSSION AND CONCLUSION

Our findings indicated that the ELQ was highly valid and reliable to measure Malaysian secondary school principals' entrepreneurial leadership behaviour. This finding emphasises the validity and reliability of the questionnaire in measuring Malaysian educational leaders' entrepreneurial leadership behaviour (Yusof, 2009). However, several items relating to principals' behaviour in fighting with school rules and bureaucracy, encouraging and challenging school members to be creative and innovative, exploring creative ways to use school resources, creating an innovative culture at school and encouraging entrepreneurial thinking and risk taking were deleted due to their low loadings to their factors. This supports Eyal and Inbar's (2003) finding that under centralised education systems, which includes Malaysia, principals have to obey the rules and do not have the freedom to implement innovative ideas and take risks in order to achieve educational goals. It also highlights the importance of principals'

capacity to create a culture in school that encourages and supports school members to think of new educational ideas and take action to implement their ideas in order to improve their task performance.

Furthermore, The findings of this study confirmed that entrepreneurial leadership is a multi-dimensional construct consisting of five leadership behaviours including general entrepreneurial behaviour (GELB), explorer behaviour (EXPB), miner behaviour (MINB), accelerator behaviour (ACCB) and integrator behaviour (INTB) (Thornberry, 2006). In particular, GELB can be defined as school principals' practices in specifying different approaches to overcome impediments, demonstrating an entrepreneurial orientation at work and actively listening to others to find innovative ways to do things. EXPB is the school principals' behaviour in motivating teachers to think of innovative educational methods, selling new educational ideas to upper managers, sharing the school vision and status with teachers and selecting the right people to capture new opportunities for school performance improvement.

MINB reflects school principals' behaviour in analysing workflow, resources and processes to improve teachers' performance, having high expectations of teachers to solve cross-school problems and supporting teachers to fight for changes and improvement. ACCB is the principals' practices in encouraging teachers to learn new skills, motivating them to engage in innovative thinking, allocating time to help them find ways to improve school

performance and change directions when results are not being achieved. Finally, INTB includes how school principals act in sharing information on new educational trends and methods, encouraging school improvement suggestions, taking action in implementing the suggestions, keeping school focused on its core strategy and supporting new educational initiatives.

This research contributes to the limited literature on entrepreneurial leadership in educational settings (Roomi & Harrison, 2011; Xaba & Malindi, 2010; Yusof, 2009). It also provides one of the first empirical findings in measuring different dimensions of educational leaders' entrepreneurial leadership behaviour (Yusof, 2009), which includes school principals' behaviour. Our findings have several implications for entrepreneurial leadership research and practice. First, the measurement model and the items emerging from this study may assist other researchers in measuring entrepreneurial leadership behaviour in educational contexts and, specifically, Malaysian secondary schools. Second, the model can be applied to measure the impact of such leadership style on various aspects of teachers' and schools' performance. Furthermore, educators may use the model to measure current entrepreneurial leadership practices at schools in order to provide professional development and training programmes for school principals and teachers and improve their entrepreneurial leadership competencies. Teacher educators can also apply the model to assess entrepreneurial

leadership behaviour among student teachers and embed entrepreneurial leadership courses and training in the current teacher education programmes in order to develop entrepreneurial leadership competencies in prospective school leaders.

Although this study provides a better understanding of how to determine entrepreneurial leadership at schools, it only focused on measuring principals' entrepreneurial leadership behaviour at secondary schools and in one district (Hulu Langat) in West Malaysia. Therefore, the findings are limited in terms of their generalisation, which cannot be applied to the larger population within the context of the study. Future research is needed to measure entrepreneurial leadership among principals in other districts and other educational levels. In addition, we only measured public secondary school teachers' perceptions toward principals' entrepreneurial leadership behaviour. Therefore, the findings should be related to school principals' entrepreneurial leadership behaviour in public school. Future research can explore if entrepreneurial leadership dimensions and the measurement model emerging from this study are valid to determine school principals' entrepreneurial leadership behaviour in private schools. Furthermore, entrepreneurial leadership behaviour of school principals was measured through teachers' perceptions. Further research should assess entrepreneurial leadership behaviour through the perspective of school principals and qualitative research methods such as observation to better

examine real entrepreneurial leadership practices in schools. Although this study asked for the participants' demographic information such as age and gender, we did not examine the impact of the factors on entrepreneurial leadership behaviour of school principals. Further research is needed to explore if the factors affect educational leaders' entrepreneurial leadership behaviour. The findings of this study also indicated that two of the entrepreneurial leadership components (GELB and MINB) were highly correlated with other constructs in the measurement model. Although the high correlation can be partially due to the conceptual similarities between the factors, future research should refine the items on the constructs in order to improve discriminant validity of the questionnaire. Further research can also be carried out to develop a standard questionnaire for measuring entrepreneurial leadership particularly in schools.

REFERENCES

- Berglund, K., & Holmgren, C. (2006). *At the intersection of entrepreneurship education policy and practice: On conflicts, tensions and closures...* Paper presented at the 14th Nordic Conference on Small Business Research, May 11, 2013, Stockholm.
- Byrne, B. M. (2010). *Structural equation modelling with AMOS: Basic concepts, applications, and programming* (second ed.). New York, London: Taylor and Francis Group.
- Chen, M. H. (2007). Entrepreneurial leadership and new ventures: Creativity in entrepreneurial teams. *Creativity and Innovation Management*, 16(3), 239-249.
- Cogliser, C. C., & Brigham, K. H. (2004). The intersection of leadership and entrepreneurship: Mutual lessons to be learned. *The Leadership Quarterly*, 15, 771-799.
- Collins, L., Hannon, P. D., & Smith, A. (2004). Enacting entrepreneurial intent: The gaps between student needs and higher education capability. *Education + Training*, 46(8/9), 454-463.
- Covin, J. G., & Slevin, D. P. (1991). A conceptual model of entrepreneurship as firm behavior. *Entrepreneurship Theory and Practice*, 16(1), 7-25.
- Eyal, O., & Kark, R. (2004). How do transformational leaders transform organizations? A study between leadership and entrepreneurship. *Leadership and Policy in Schools*, 3(3), 211-235.
- Eyal, O., & Inbar, E. D. (2003). Developing a public school entrepreneurship inventory: Theoretical conceptualization and empirical examination. *International Journal of Behaviour and Research*, 9(6), 221-244.
- Fernald, L. W. Jr., Solomon, G. T., & Tarabishy, A. (2005). A new paradigm: Entrepreneurial leadership. *Southern Business Review*, 30(2), 1-10.
- Gupta, V., MacMillan, I. C., & Surie, G. (2004). Entrepreneurial leadership: Developing and measuring a cross-cultural construct. *Journal of Business Venturing*, 19, 241-260.
- Hair, J. F., Black, W. C., Babin, B. J., & Anderson, R. E. (2010). *Multivariate data analysis*. 7th Edn., Pearson Prentice Hall, United States of America.
- Hentschke, G. C. (2009). Entrepreneurial leadership. In B. Davies. *The essentials of school leadership* (2nd Ed) (pp.147-165). London: Sage Publishing Co.
- Holt, D. T., Rutherford, M. W., & Clohessy, G. R. (2007). Corporate entrepreneurship: An empirical look at individual characteristics,

- context, and process. *Journal of Leadership and Organizational Studies*, 13(4), 40-54.
- Hytti, U., & O’Gorman, C. (2004). What is “enterprise education”? An analysis of the objectives and methods of enterprise education programs in four European countries. *Education + Training*, 46(1), 11-23.
- Kline, R. B. (2010). *Principles and practice of structural equation modeling* (3rd ed.). New York: Guilford Press.
- Kempster, S. J., & Cope, J. (2010). Learning to lead in the entrepreneurial context. *Journal of Entrepreneurial behaviour and Research*, 16(6), 5-34.
- Kempster, S. J. (2009). Observing the invisible: Examining the role of observational learning in the development of leadership practice. *Journal of Management Development*, 28(5), 439-456.
- Kempster, S. J. (2006). Leadership learning through lived experience: A process of apprenticeship? *Journal of Management and Organization*, 12(1), 4-22.
- Kickul, J., & Gundry, L. K. (2002). Prospecting for strategic advantage: The proactive entrepreneurial personality and small firm innovation. *Journal of Small Business Management*, 40, 85–97.
- Klein, P. G., & Bullock, J. B. (2006). Can entrepreneurship be taught? *Journal of Agricultural and Applied Economics*, 38(2), 429-439.
- Kuratko, D. F. (2007). Entrepreneurial leadership in the 21st century. *Journal of Leadership and Organizational Studies*, 13(4), 1-11.
- Kuratko, D. F., Hornsby, J. S., & Goldsby, M. G. (2007). The relationship of stakeholder salience, organizational posture, and entrepreneurial intensity to corporate entrepreneurship. *Journal of Leadership and Organizational Studies*, 13(4), 56-72.
- Kuratko, D. F., & Hornsby, J. S. (1999). Corporate entrepreneurial leadership for the 21st Century. *Journal of Leadership and Organizational Studies*, 5(27), 27-39.
- Leitch, C. M., McMullan, C., & Harrison, R. T. (in press). The development of entrepreneurial leadership: The role of human, social and institutional capital. *British Journal of Management*.
- Lumpkin, G. T., & Dess, G. G. (1996). Clarifying the entrepreneurial orientation construct and linking it to performance. *Academy of Management Review*, 21(1), 135-72.
- Mattare, M. *Teaching entrepreneurship: The case for an EL course*. In Proceedings of USASBE conference, 78-93, USA, (2008).
- Mohd. Sahandari Gani Hamzah, Hamidah Bt. Yusof, Saifuddin Kumar Abdullah. (2009). Headmasters and entrepreneurship criteria. *European Journal of Social Sciences*, 11(4), 535-543.
- Morris, M., Coombes, S., Schindehutte, M., & Allen, J. (2007). Antecedents and outcomes of entrepreneurial and market orientations in non-profit context: Theoretical and empirical insights. *Journal of Leadership and Organizational Studies*, 13(4), 12-39.
- Mueller, S. L., & Thomas, A. S. (2000). Culture and entrepreneurial potential: A nine country study of locus of control and innovativeness. *Journal of Business Venturing*, 16, 51–75.
- Nicholson, N. (1998). Personality and entrepreneurial leadership: A study of the heads of the UK’s most successful independent companies. *European Management Journal*, 16(5), 529-539.
- Okudan, G. E., & Rzasa, S. E. (2006). A project-based approach to entrepreneurial leadership education. *Technovation*, 26, 195-210.
- Pan, Y., & Fond, M. (2010). Developing multilingual questionnaires: A sociolinguistic perspective.

- Section on Survey Research Methods*, 2197-2210.
- Park, J. H. (2012). The effects of principal's leadership style on support for innovation: evidence from Korean vocational high school change. *Asia Pacific Education Review*, 13, 89–102.
- Rae, D. (2007). Connecting enterprise and graduate employability: Challenges to the higher education culture and curriculum? *Education + Training*, 49(8/9), 605-619.
- Roomi, M. A., & Harrison, P. (2011). Entrepreneurial leadership: What is it and how should it be taught? *International Review of Entrepreneurship*, 9(3). Senate Hall Academic Publishing.
- Schreiber, J. B., Nora, A., Stage, F. K., Barlow, E. A., & King, J. (2006). Reporting structural equation modeling and confirmatory factor analysis results: A review. *The Journal of Educational Research*, 99(6), 323-338.
- Swiercz, P. M., & Lydon, S. R. (2002). Entrepreneurial leadership in high-tech firms: A field study. *Leadership and Organization Development Journal*, 23(7), 380-386.
- Thornberry, N. (2006). *Lead like an entrepreneur*. Blacklick, OH: McGraw-Hill.
- Vecchio, R. P. (2003). Entrepreneurship and leadership: Common trends and common threads. *Human Resource Management Review*, 13, 303–327.
- Xaba, M., & Malindi, M. (2010). Entrepreneurial orientation and practice: Three case examples of historically disadvantaged primary schools. *South African Journal of Education*, 30, 75-89.
- Yusof, M. (2009). Entrepreneurial leadership and academic entrepreneurship in Malaysian public research universities. *Asia Pacific Journal of Innovation and Entrepreneurship*, 3(3), 63-84.
- Zampetakis, L. A. (2008). The role of creativity and proactivity on perceived entrepreneurial desirability. *Thinking Skills and Creativity*, 3, 154–162.
- Zhao, H., Seibert S. E., & Hills, G. E. (2005). The mediating role of self-efficacy in the development of entrepreneurial intentions. *Journal of Applied Psychology*, 90(6), 1265–1272.

APPENDIX

A: QUESTIONNAIRE ITEMS

Indicate your level of agreement with the following statements from 1 (strongly disagree) to 5 (strongly agree).

EXP1	Spends time on new strategies for school development.	<input type="checkbox"/>	<input type="checkbox"/>	<input type="checkbox"/>	<input type="checkbox"/>	<input type="checkbox"/>
EXP2	Points out the competition’s weaknesses and how we could exploit them.	<input type="checkbox"/>	<input type="checkbox"/>	<input type="checkbox"/>	<input type="checkbox"/>	<input type="checkbox"/>
EXP3	Listens to and acts upon school stakeholders’ complaints.	<input type="checkbox"/>	<input type="checkbox"/>	<input type="checkbox"/>	<input type="checkbox"/>	<input type="checkbox"/>
ACC1	Challenges us to think about new and better ways to do our work.	<input type="checkbox"/>	<input type="checkbox"/>	<input type="checkbox"/>	<input type="checkbox"/>	<input type="checkbox"/>
GEL1	Encourages the bending/circumvention of the school rules when they get in the way of achieving educational goals.	<input type="checkbox"/>	<input type="checkbox"/>	<input type="checkbox"/>	<input type="checkbox"/>	<input type="checkbox"/>
MIN1	Assertively communicates to upper manager regarding how things could be run better.	<input type="checkbox"/>	<input type="checkbox"/>	<input type="checkbox"/>	<input type="checkbox"/>	<input type="checkbox"/>
MIN2	Looks for creative ways to manage, use, or rearrange the school assets and resources.	<input type="checkbox"/>	<input type="checkbox"/>	<input type="checkbox"/>	<input type="checkbox"/>	<input type="checkbox"/>
EXP4	Passionately looks for new ways to grow the school.	<input type="checkbox"/>	<input type="checkbox"/>	<input type="checkbox"/>	<input type="checkbox"/>	<input type="checkbox"/>
EXP5	Motivates us to think of innovative ways to beat the competition.	<input type="checkbox"/>	<input type="checkbox"/>	<input type="checkbox"/>	<input type="checkbox"/>	<input type="checkbox"/>
EXP6	Effectively sells new educational ideas to upper management.	<input type="checkbox"/>	<input type="checkbox"/>	<input type="checkbox"/>	<input type="checkbox"/>	<input type="checkbox"/>
ACC2	Supports our suggestions for improving the school.	<input type="checkbox"/>	<input type="checkbox"/>	<input type="checkbox"/>	<input type="checkbox"/>	<input type="checkbox"/>
GEL2	Gets things done even if it means going around the system.	<input type="checkbox"/>	<input type="checkbox"/>	<input type="checkbox"/>	<input type="checkbox"/>	<input type="checkbox"/>
INT1	Communicates a vision of how the school could be better in the future if we were to make certain improvements.	<input type="checkbox"/>	<input type="checkbox"/>	<input type="checkbox"/>	<input type="checkbox"/>	<input type="checkbox"/>
ACC3	Encourages us to challenge the status quo.	<input type="checkbox"/>	<input type="checkbox"/>	<input type="checkbox"/>	<input type="checkbox"/>	<input type="checkbox"/>
MIN3	Makes sure that we keep the school stakeholders in mind when making changes to our school.	<input type="checkbox"/>	<input type="checkbox"/>	<input type="checkbox"/>	<input type="checkbox"/>	<input type="checkbox"/>
EXP7	Tells us where we stand <i>vis-a-vis</i> the competition.	<input type="checkbox"/>	<input type="checkbox"/>	<input type="checkbox"/>	<input type="checkbox"/>	<input type="checkbox"/>
ACC4	Pushes us to innovate in how we do our work.	<input type="checkbox"/>	<input type="checkbox"/>	<input type="checkbox"/>	<input type="checkbox"/>	<input type="checkbox"/>
EXP8	Actively identifies, develops and goes after new education opportunities.	<input type="checkbox"/>	<input type="checkbox"/>	<input type="checkbox"/>	<input type="checkbox"/>	<input type="checkbox"/>
EXP9	Makes sure that we have the right team of people in place to successfully capture these new opportunities.	<input type="checkbox"/>	<input type="checkbox"/>	<input type="checkbox"/>	<input type="checkbox"/>	<input type="checkbox"/>
ACC5	Displays enthusiasm for our learning new skills.	<input type="checkbox"/>	<input type="checkbox"/>	<input type="checkbox"/>	<input type="checkbox"/>	<input type="checkbox"/>
ACC6	Quickly takes a different direction when results aren’t being achieved.	<input type="checkbox"/>	<input type="checkbox"/>	<input type="checkbox"/>	<input type="checkbox"/>	<input type="checkbox"/>
ACC7	Encourages others to take the initiative and action for their own ideas.	<input type="checkbox"/>	<input type="checkbox"/>	<input type="checkbox"/>	<input type="checkbox"/>	<input type="checkbox"/>
ACC8	Motivates teachers to think about how to do their work in new and interesting ways.	<input type="checkbox"/>	<input type="checkbox"/>	<input type="checkbox"/>	<input type="checkbox"/>	<input type="checkbox"/>
ACC9	Allots time to helping teachers find ways to improve our school performance.	<input type="checkbox"/>	<input type="checkbox"/>	<input type="checkbox"/>	<input type="checkbox"/>	<input type="checkbox"/>
ACC10	Creates a climate that encourages continuous improvement.	<input type="checkbox"/>	<input type="checkbox"/>	<input type="checkbox"/>	<input type="checkbox"/>	<input type="checkbox"/>
GEL3	Willingly moves ahead with a promising new approach when others might hold back.	<input type="checkbox"/>	<input type="checkbox"/>	<input type="checkbox"/>	<input type="checkbox"/>	<input type="checkbox"/>
GEL4	Promotes an environment where risk taking is encouraged.	<input type="checkbox"/>	<input type="checkbox"/>	<input type="checkbox"/>	<input type="checkbox"/>	<input type="checkbox"/>

Entrepreneurial Leadership among School Principals

INT2	Identifies, encourages, and protects rebels who might think and act differently than the majority of the school staff.	<input type="checkbox"/>	<input type="checkbox"/>	<input type="checkbox"/>	<input type="checkbox"/>	<input type="checkbox"/>
GEL5	Encourages others to outwit and out-maneuver the school's bureaucracy.	<input type="checkbox"/>	<input type="checkbox"/>	<input type="checkbox"/>	<input type="checkbox"/>	<input type="checkbox"/>
GEL6	Quickly utilises different approaches to overcoming obstacles when the initial one doesn't work.	<input type="checkbox"/>	<input type="checkbox"/>	<input type="checkbox"/>	<input type="checkbox"/>	<input type="checkbox"/>
ACC11	Creates an environment where school teachers feel free to try new things.	<input type="checkbox"/>	<input type="checkbox"/>	<input type="checkbox"/>	<input type="checkbox"/>	<input type="checkbox"/>
MIN4	Challenges us to creatively discover ways to do more with less.	<input type="checkbox"/>	<input type="checkbox"/>	<input type="checkbox"/>	<input type="checkbox"/>	<input type="checkbox"/>
GEL7	Demonstrates an entrepreneurial orientation at work.	<input type="checkbox"/>	<input type="checkbox"/>	<input type="checkbox"/>	<input type="checkbox"/>	<input type="checkbox"/>
INT3	Pushes the school to be fast, flexible, and adaptable so that we can react quickly when new educational opportunities arise.	<input type="checkbox"/>	<input type="checkbox"/>	<input type="checkbox"/>	<input type="checkbox"/>	<input type="checkbox"/>
GEL8	Actively fights the encroachment of bureaucracy in the school.	<input type="checkbox"/>	<input type="checkbox"/>	<input type="checkbox"/>	<input type="checkbox"/>	<input type="checkbox"/>
INT4	Utilises an extensive network of people throughout the school that is willing to help if called upon.	<input type="checkbox"/>	<input type="checkbox"/>	<input type="checkbox"/>	<input type="checkbox"/>	<input type="checkbox"/>
MIN5	Analyses work flow, resources, processes and procedures to see how we can do our work better, faster and with better impact on students' achievements.	<input type="checkbox"/>	<input type="checkbox"/>	<input type="checkbox"/>	<input type="checkbox"/>	<input type="checkbox"/>
MIN6	Expects us to constructively identify and solve cross-school problems and issues.	<input type="checkbox"/>	<input type="checkbox"/>	<input type="checkbox"/>	<input type="checkbox"/>	<input type="checkbox"/>
GEL9	Willingly listens to suggestions from others about how to do things differently.	<input type="checkbox"/>	<input type="checkbox"/>	<input type="checkbox"/>	<input type="checkbox"/>	<input type="checkbox"/>
MIN7	Supports us in fighting for changes that will improve the way the school works.	<input type="checkbox"/>	<input type="checkbox"/>	<input type="checkbox"/>	<input type="checkbox"/>	<input type="checkbox"/>
INT5	Strives to build an innovative culture within our school.	<input type="checkbox"/>	<input type="checkbox"/>	<input type="checkbox"/>	<input type="checkbox"/>	<input type="checkbox"/>
INT6	Encourages entrepreneurial thinking and risk taking.	<input type="checkbox"/>	<input type="checkbox"/>	<input type="checkbox"/>	<input type="checkbox"/>	<input type="checkbox"/>
INT7	Reacts quickly to remove organisational barriers that get in the way of implementing educational strategies.	<input type="checkbox"/>	<input type="checkbox"/>	<input type="checkbox"/>	<input type="checkbox"/>	<input type="checkbox"/>
INT8	Encourages open communication and sharing ideas across school units and functions.	<input type="checkbox"/>	<input type="checkbox"/>	<input type="checkbox"/>	<input type="checkbox"/>	<input type="checkbox"/>
INT9	Keeps the school informed and updated on new educational trends and methods to improve students' learning and achievement.	<input type="checkbox"/>	<input type="checkbox"/>	<input type="checkbox"/>	<input type="checkbox"/>	<input type="checkbox"/>
INT10	Actively encourages school improvement suggestions throughout the school.	<input type="checkbox"/>	<input type="checkbox"/>	<input type="checkbox"/>	<input type="checkbox"/>	<input type="checkbox"/>
INT11	Takes action to implement many of these suggestions.	<input type="checkbox"/>	<input type="checkbox"/>	<input type="checkbox"/>	<input type="checkbox"/>	<input type="checkbox"/>
INT12	Keeps the school focused on its core strategy but also supports new educational initiatives.	<input type="checkbox"/>	<input type="checkbox"/>	<input type="checkbox"/>	<input type="checkbox"/>	<input type="checkbox"/>
INT13	Puts aside money outside of the normal budget process in order to fund and support innovative ideas.	<input type="checkbox"/>	<input type="checkbox"/>	<input type="checkbox"/>	<input type="checkbox"/>	<input type="checkbox"/>
INT14	Encourage school staff to challenge their decisions.	<input type="checkbox"/>	<input type="checkbox"/>	<input type="checkbox"/>	<input type="checkbox"/>	<input type="checkbox"/>



Assessing Graduates' Generic Skills: An Indicator of Employability

Parmjit Singh^{1*}, Roslind Xaviour Thambusamy² and Adlan Ramly²

¹*Mathematics Department, Faculty of Education, Campus Sec. 17, Universiti Teknologi MARA, Malaysia, 40200 Shah Alam, Selangor, Malaysia*

²*TESL Department, Faculty of Education, Campus Sec. 17, Universiti Teknologi MARA, Malaysia, 40200 Shah Alam, Selangor, Malaysia*

ABSTRACT

This concept paper seeks to discuss the issues of the measurement of Malaysian university graduates' generic skills as an indicator of their employability in the real world job market. Despite the heated discussions and arguments among stakeholders on the problem of rampant unemployment of fresh university graduates, there is still a distinct absence of a valid screening tool to test the level of work readiness of the university students before they are awarded their scrolls. Starting July 2006, the Malaysian Ministry of Higher Education (MOHE) instituted the implementation of seven generic skills to be incorporated into the tertiary curriculum in an effort to address and redress the shortcomings in graduate employability. This worthy effort however, has been stymied by the somewhat informal, subjective, and lackadaisical treatment of the generic skills component in the actual implementation. This, coupled with the absence of a validated exit screening tool, undermines all serious efforts to ensure that graduates are genuinely work ready. This concept paper proposes a model called Graduate Employability Model (GEM) as a framework that policy makers and higher education practitioners could use to generate a more stringent quantitative and summative quotient of the future graduates' employability as indicated by their generic skills.

Keywords: Generic skills, employability skills, assessment tool, screening tool, model, framework

ARTICLE INFO

Article history:

Received: 2 April 2013

Accepted: 28 October 2013

E-mail address:

parmj378@salam.uitm.edu.my (Parmjit Singh)

* Corresponding author

INTRODUCTION

Someone once said that all you have to do to stop a child from thinking is to send him to school. Sadly, one cannot help but agree with this dismal statement in considering

the current Malaysian education system which rewards rote learning, as evidenced by the annual celebratory lauding in the media of candidates scoring strings of A's in national examinations. This penchant for garnering as many A's as possible is directly responsible for the mushrooming of private tuition centers that offer "crash courses" designed to cram the children with "model" answers which, duly memorized, produce the desired A's. (Bray, 2007). In the preface to this seminal publication on the global phenomenon of private tutoring, the general editor contends that

"Training pupils for examinations only may not be the best training that can take place. Cramming is often to the detriment of creative learning and may not lead to the expected increase in human capital." (Bray, 2007, p.11)

This sad state of affairs has led the Malaysian Prime Minister to recently declare that education has hitherto emphasized memorization (the what part) and that this has to be changed to emphasize to the thinking process (the how part) so that students can utilize the knowledge gained to their advantage in innovative and creative ways. In attending to the issues that such rote learning has engendered, the Prime Minister has declared that it is necessary

"... to bring about an education transformation where the essence is to motivate students to think because we want to create a generation which

can think creatively, innovatively and critically, as well as think out of the box and resolve problems... The world has changed. We need to prepare the present generation to face the world of the future which will surely be much different from that of today," (Bernama, 2012, para. 3-4)

The Prime Minister's concern about the need to "create a generation which can think creatively, innovatively and critically, as well as think out of the box and resolve problems" is shared by many concerned stakeholders, particularly the employers who have to deal with the thousands of graduates pouring out of the numerous higher education institutions (henceforth HEIs) every year, the bulk of whom do not fit the bill as articulated by the Prime Minister.

The need to produce thinking graduates has become all the more important nowadays as the world has changed, and with it, the requirements and needs of the working environment. What worked 50, or even 30 years ago, does not work now, and graduates need to be equipped with both content-specific technical knowledge as well as skills, such as ICT and 'tech-savvy-ness' that their forebears had no need of. The challenges facing new graduates today are formidable as "the contemporary requirements of the economy which is characterized by the globalization of national economies, rapidly-changing markets, increased global competition for

goods and labour, technological innovations and the movement from mass production to flexible specialization in the production process” (Teh & Pendergast, 2009) and the subsequent elimination of physical boundaries through the advent of ICT has necessitated the sharpening of skills related to communication, entrepreneurship, and life-long learning in order to keep pace with the global strides in all areas of human endeavor.

How have the Malaysian HEIs addressed these issues and concerns in their pedagogical and curricular approaches? From the data provided by the Malaysian Department of Statistics, it appears that the situation is worrying. There seems to be a massive gap between what higher education is providing and what the employers are seeking in graduates. This is borne out by the statistics which revealed that from 2007 until 2010, the number of unemployed graduates had steadily increased to over 30,000 at both the diploma and degree levels (Department of Statistics, 2011). These 30,000 unemployed graduates, many of whom were educated at the taxpayers' expense at the 20 public universities in Malaysia (Norshima, 2008) is indeed a grim statistic and one that rightly deserves the approbation of the stakeholders like parents and employers.

There is obviously a glaring mismatch between the products, that is the graduates, and the mission of higher education when such an uncomfortable number of fresh graduates remain unemployed after graduation, or are forced to take

on jobs which do not require degree qualifications. In a bizarre turn of events, while an increasing number of graduates end up being unemployed, 67% of private companies increased “the size of their current international assignee population” in 2008 (Sri Ramalu, Che Rose, Uli, & Kumar, 2010), indicating that employers seem to favor foreigners and expatriates over local graduates. This scenario should immediately trigger several concerns, the outstanding one being that our graduates are apparently unworthy employee material as compared to foreigners, and second is that the output of our higher education is obviously below par compared to that of foreign universities. This however, is highly unlikely in terms of the syllabus and content being offered at Malaysian universities, as these are subject to review and revision according to the latest professional standards and trends worldwide in line with the Malaysian Qualifications Agency's mandates. Therefore, it may be assumed that the problem lies not so much in the content of the courses being offered as the development of the students themselves. Thus, what matters now is the personal development of the graduate, as opposed to his or her mastery of technical content (Orr, 1991, page number?). In other words, it is high time that the focus of higher education be redirected from the “what” (content material) to the “how” (referring to the “generic skills”) as it contributes to the development of the “who” (the graduate). A fitting prelude to an in-depth discussion regarding these issues, is the premise that underscores

this issue of why the “what”, “how” and “who” resonates deeply with the notion of “employability”. Unlike yesteryears, when university education was the bastion of the intellectually elite and academically inclined, and where professors displayed scant concern over issues of employability, considering such matters as beneath their intellectual/academic purview, graduates were expected to develop generic or work-related skills peripherally as an indirect or covert application of content knowledge and the socialization that campus life offered. However, with the democratization and subsequent massification of higher education, the doors of the ivory towers were thrown open to the ‘masses’ seeking to better their socio-economic prospects through the ‘paper chase’. Suddenly, the economic considerations of a university education began to impinge on the academic consciousness, with words like ‘marketability’, ‘employability’, and ‘soft’, ‘hard’, and ‘generic skills’ infiltrating curricular considerations. Universities, particularly the more traditional establishments, now in direct competition with the numerous private, for-profit higher education providers that were mushrooming to take advantage of the demand for higher education, had to quickly reconfigure their academic paradigm to accept the fact that higher education institutions could no longer operate as ‘ivory towers’ detached from the world around them. HEIs were now being held directly responsible for their “products” as these graduates entered the working world. With lifelong learning being touted

as an exemplary habit in the new work order, the clarion call to keep learning quickly became a pivotal prerequisite justifying the need for higher education. Learning, lifelong and otherwise, began to be espoused as the panacea for socio-economic development of nations, with skills related to employability becoming embedded in higher education curricula to cater for the needs and vagaries of the burgeoning global marketplace.

It is clear then that the premise of higher education today far exceeds the statistics of passes and excellent achievements in university examinations. The burning question for higher education practitioners is not whether our undergraduates are performing well in examinations, but rather whether we are preparing them adequately for the working world? This question cannot, however, be easily answered. By all accounts, given the MOHE’s mandate to implement the seven generic skills (these skills are detailed in page 7) into the Malaysian higher education curricula since 2007 (Ministry of Higher Education, 2007), things should be working like clockwork. Still, the hard, cold facts as indicated by the statistics have proven otherwise. What does emerge from this paradox is that if the content is beyond question and the generic skills are already being imparted in the curricula, then it is the students’ actual capabilities (when they graduate) that we should be focusing on. This further begs the question that if we have an intricate and comprehensive system of screening for university entrance via the national school leaving examinations and the Malaysian English University

Test (MUET), why do we not exert the same fervor and comprehensiveness to screen their capabilities before they graduate? Other than examinations, which to all intents and purposes only test content knowledge, why have we not measured their communicative competency, their problem solving skills, critical thinking abilities and those other elements that would determine their employability? Consequently, this conceptual paper seeks to justify the need for and propose a model that would indicate definitively the work-worthiness of students before they are allowed to graduate. Obviously, such a model would require the requisite grounding in order to justify its standing and this will appear in the next portion of this paper.

OBJECTIVE

The objective of this paper is to discuss the issue of graduate employability, generic skills and the assessment of both in the current tertiary educational context and to suggest a model or framework that can be used to construct an instrument for such purpose. The specific objectives of this paper are:

1. To discuss employability and the issue of unemployment among fresh Malaysian graduates.
2. To elucidate the relation between employability and generic skills.
3. To discuss the importance of a valid exit screening test for graduates and the current trend of assessment for generic skills in universities.

4. To propose a framework called the Graduate Employability Model (GEM) as a feasible exit assessment tool of graduating students' generic skills.

SIGNIFICANCE OF THE STUDY

This paper hopes to drive home the point that this model, premised on the need for a stringent assessment of generic skills prior to graduation, would help to stem the employability issues that currently plagues the Malaysian higher education. With a model like this in place, Malaysian HEIs will have in hand, a comprehensive assessment tool that can act as an all-purpose indicator of employability which serves not just employers but also the graduates and HEIs. This tool, when efficiently deployed, will enable all stakeholders to get a clear view of graduate capabilities. Apart from certification of their technical knowledge, the graduates will be provided with an additional evaluation, that of their generic skills, acknowledging them as fit for the world of work. If they fail to display the requisite skills, the model can identify and isolate those specific areas of weakness which can then be targeted for improvement or enhancement. In this way, graduates will be able to focus on those areas which they need to improve before they seek employment, saving both themselves and prospective employers frustration and heartache. The HEIs, through this model, will be able to gauge the extent to which the implementation of generic skills as curricula or co-curricula elements has been successful, and embark on remedial

measures if the implementation is found lacking. Thus, implementing such a model is a win-win situation for all stakeholders concerned where so much that is wrong in the current employability scenario can be redressed and alleviated.

As always, while the notion may be impeccable, the implementation is open to interpretation and this is where some limitations may arise. Each HEI, having their own mission and vision may skew the components of the generic skills to be assessed to align to their respective institutional mission and vision, which will naturally upset the fine balance of the assessment criteria. A case in point is Universiti Teknologi MARA, which having been recently declared an entrepreneurial university, is in the process of inculcating the tenets of entrepreneurialism in its coursework, wherever possible. With such a paradigm, it is inevitable that the entrepreneurial skill (among the seven MOHE endorsed generic skills) will be emphasized when graduates are assessed on their soft skills using this model. This can become a setback in providing a balanced picture of the gamut of skills required by graduates to be 'properly' employable.

LITERATURE REVIEW

In this section, employability and the manner in which generic skills insinuate themselves into a workable premise of the notion of employability is presented with a view to justifying the need for the incorporation of a model to assess the generic skills of graduates in order to ensure

that they emerge ready for work from the HEIs. The premise of this discussion and the justification of a university exit model to assess graduate work-related competencies is clearly supported by Yorke (2006, p.4) who contends that

“When trying to appreciate higher education’s potential for contributing to economic wellbeing it is helpful to distinguish between the formation of subject-specific understandings and skills, and the promotion of other valued skills, qualities and dispositions. Whereas the world of employment has, by and large, been satisfied with the disciplinary understanding and skills developed as a consequence of participation in higher education, it has been less happy with the development of what have been termed ‘generic skills’, such as communication, team-working and time-management.”

Employability

The concept of employability is neither recent nor under-defined, having been elucidated and elaborated by many researchers in this area. (Asnida, (2003); Chiam, (2005); Hesketh, (2000); Hinchliffe, (2002); Holmes, (2001); Gibbons, (2000); Knight & Yorke, (2004); Leon, (2002); Morley, L. (2001); Pierce, (2002); Purcell & Elias, (2002); Stephenson, (1998); Wolf, (2002); Yorke & Knight, (2006); Ong, (2006); Marina, (2007); Norizan,

et al.,(2006)). These works represent but a fragment of the immense undertaking of researchers in this area which reflects the importance attached to the notion of employability all over the world.

One of the most applicable in general terms would be the definition provided by the United Kingdom Institute of Employment that characterizes employability as possessing the capability to acquire, maintain and seek for newer (if necessary) employment or a job and that such capabilities include:

“their assets in terms of the knowledge, skills and attitudes they possess; the way they use and deploy those assets; the way they present them to employers; and crucially, the context (e.g. personal circumstances and labor market environment) within which they see work” (Hillage & Pollard, 1998 p.1).

Yorke (2006, p.21) sums up the tenets of employability as

“A set of skills, knowledge and personal attributes that make an individual more likely to secure and be successful in their chosen occupation(s) to the benefit of themselves, the workforce, the community and the economy.”

This supports the notion that (content) knowledge per se contributes to only a small portion of the understanding of

employability while the rest include personal attitudes and the ability to manipulate and use the knowledge in creative and practical ways as required by the needs (Orr, 1991). Brown, Hesketh, and Williams (2002) similarly defined employability as a notion that encapsulates the very economic and political pathos of a certain country and that in the current global economic climate, the efficiency of the economy depends on the population's capability to acquire the knowledge, skills, and capabilities that employers need in an increasingly knowledge-driven economy. Here too, knowledge is part of a package deal that includes skills and specific work-related capabilities which should reflect the employers' needs.

An even more cogent definition is given by Mantz Yorke (2006) who posited that employability is not the same as employment. Yorke argued that those graduates who acquired employment may not actually possess the quality of employability depending on the needs, climate, and type of employment that are acquired. For example, an engineering graduate who is employed as a bartender may not possess the qualities of employability (for his field) although he is employed. In other words, those who are employed may not necessarily reflect high employability. This makes the discussion on employability difficult as it shows that mere statistics of employment and unemployment are not reliable indicators of the graduates' employability. To gauge such a tenuous attribute, quantitative data based on surveys or examinations must first be acquired.

In creating a tenable assessment of the employability of graduates and soon-to-graduate university students, the inclusion of “soft skills” or “generic skills” is a prerequisite. Ian Hampson and Anne Junor (2010) for example, contend that “soft skills” have been under-rated until lately and that this does not encompass merely the technical content of the students’ knowledge, but how they are used in the social context of the working environment. But what are these soft or generic skills? Are they solely social or do they have deeper implications?

Generic Skills and its Relation to Employability

To begin with, it is difficult to precisely define what “generic skills” are. Nonetheless, although its definition is elusive, we can begin to glean an understanding of these skills by roughly knowing what they are not. Generic skills are not technical skills or the content knowledge of a certain field or specialized area. For example, knowing the theory of aerodynamics is not part of the generic skills that an aeronautic engineer should possess. Similarly, a deep knowledge of a particular subject does not automatically make a good teacher as effective teaching is predicated upon knowing not just what to teach but how to teach. Such content-derived knowledge, referred to the “hard skills” are related to the specialized knowledge and skills that can be properly analyzed, defined, and tested. These are usually termed technical skills (Turner, 2004).

If technical knowledge or hard skills form one part of the employability package,

then soft skills or the generic skills refer to the range of skills that form the other part of the package. These generic skills complement the hard skills in the work place as they deal with those capabilities that employees would need to utilise to function competently in any organisation. First and foremost, it is important to note that the nomenclature for generic skills is varied, depending on contextual application, and among the names that it is known by include: “key competencies”, “core skills” and “employability skills” (Md. Yunus et al., 2005). The dimensions of these skills are also wide and subject to interpretation. Leon and Borcehrs (2002) for example, grouped them into skills of reading, writing and math; communication; critical thinking; group interactions; personal development; computer skills; technical systems; leadership; and team work (cited in Agus et al., 2011). Koo (2007, pp.39), on the other hand, suggested a “pluriliteracy” related to employability skills that included linguistic proficiency, communicative literacy, cultural awareness, content literacy, sustainable citizenship, attitudes and mindset, vocational literacy, and critical literacy.

Returning to the issue of unemployment of the Malaysian graduates, the Malaysian Ministry of Higher Education has acknowledged the importance of generic skills and instituted its implementation in the higher education curriculum since 2007. In 2006, Datuk Mustapa Mohamed, then the higher education minister, announced that the ministry considered generic skills a serious matter and suggested a model of generic

skills that comprised “communication skill; critical thinking and problem solving; teamwork; lifelong learning and information management; ethics and professional morals; entrepreneurship; and leadership skill.” (Yassin et al., 2008). Given that universities have now become responsible for producing employable graduates, it is only logical that the attainment of generic skills are being emphasized. Shyamal (2009) noted that among the reasons for such emphasis are:

- (1) *the requirements of the knowledge-based new economy and continuing impact of globalization and new information technologies;*
- (2) *the exponential pace of change;*
- (3) *the consequent pressures of life-long learning;*
- (4) *the need for individuals to maintain employability;*
- (5) *changes in the workplace;*
- (6) *requirement to foster enterprise skills and innovation culture in some countries, among the few” (p. 2).*

As can be seen from the reasons stated above, much of the need originates from the expectancy of economic demands that employers have to meet. The salient implication here is that in today’s highly globalized and increasingly competitive world where work places and opportunities are no longer physically constrained, the adaptability and transference of skills and competencies is highly prized and coveted by employers seeking to reap

the optimal economic rewards from their choice of employees. In such a scenario, it is no wonder that, generic skills have significantly become the determining factor of employability (Othman, 2012). Thus, we are obliged to ask ourselves whether our universities are producing graduates with the relevant generic skills.

Generic Skills Assessment & Screening Tools Worldwide and their Significance in Malaysia

Outside Malaysia, the idea of assessing graduates to ensure their non-academic skills are sufficient is not a new practice. The University of Cambridge for example, developed and introduced the Thinking Skills Assessment in 2001 which tests problem solving skills and critical thinking skills. This test is now used by 27 out of its 29 colleges and branches (TSA Cambridge, 2008). At present, the test is being used by the University of Cambridge, the University of Oxford and University College London as an exit screening test for its undergraduates. Similarly, the Australian government has taken the initiative to gauge the Australian graduates’ generic skills by devising the Graduate Skills Assessment, better known as the GSA. Utilizing the four elements of Critical Thinking, Problem Solving, Interpersonal Understanding and Written Communication Skills, the GSA was first implemented in 2000 and the validity study shows a significant advantage in utilizing the test in increasing the graduates’ employability (Hambur, Rowe, & Luc, 2002). Another Australian effort,

implemented by the Australian Learning and Teaching Council (ALTC) is called Embedding the Development and Grading of Generic Skills in the Business Curriculum (EDGGS). Unlike the GSA, the EDGGS is a series of assessments that are invigilated at the end of each year (every two semesters) of the students' study period in the university and involves the four generic skills of teamwork, critical thinking, ethical practice, and sustainable practice or the consistency of the graduates to improve and maintain the first three skills (Thomas et al., 2009). In the United States, efforts in assessing generic skills have been undertaken by the American College Testing Centre for Education and Work in which the Work Keys System that covers the employability skills of "Reading for Information, Applied Mathematics, Listening, Writing, Locating Information, Applied Technology, and Teamwork" were introduced as early as 1994 (Saterfiel & McLarty, 1995).

A cursory observation of all these tools reveals that the main components used in these various generic skills assessments are Problem Solving Skills, Critical Thinking Skills, Interpersonal Skills, and Communicative Skills. These components are often used not only because they are the most feasible to assess, but also because of their significance in portraying an individual's employability. Problem Solving and Critical Thinking skills are good indicators of the graduates' ability to use their expert knowledge in creative and innovative ways while Interpersonal and Communicative Skills allow them

to convey their ideas in a clear, effective manner. An effective amalgamation and application of these skills would contribute indirectly to the creation of positive working environments, which would understandably result in better production and reductions of costs for the employer.

The discussion thus far can now be related to the issue of "what", "how" and "who" as raised at the beginning of this paper. We can begin to understand that the graduates' technical knowledge and expertise can be considered the "what", whereas their ability to use problem solving and critical thinking in creative and innovative ways and their effectiveness of relaying such ideas to other parties in a real working context refers to the "how". The manner, in which these two separate strands are inextricably linked within the development of the "who", is at the heart of the employability issue.

Now, the important question to ask here is that, while generic skills assessment tools are being used worldwide as an indicator of employability, why have we, in Malaysia, not come up with a sound screening tool that can be used to gauge our graduates' work readiness? University entrance is subject to a strict screening process, whereby on top of the high academic standards that the students need to attain in their Sijil Pelajaran Malaysia (equivalent to O-levels), Sijil Tinggi Pelajaran Malaysia (equivalent to A-levels), and Matriculation examinations, the candidates are further filtered through a battery of interviews, written assessments, practical auditions

and tests for particular courses. It seems then that the university entrance procedures emphasize high standards of quality control in selecting the candidates. Why then are the same high standards of quality control not exerted before the students are allowed to graduate? This question is all the more confounding, knowing that generic skills have already been acknowledged as vital to graduates' employment.

Having recognized the importance of these skills, MOHE has instructed Malaysian HEIs to implement generic skills into their curricular content since 2007. However, the universities have been given the mandate to inculcate these skills into the students in whatever manner they see fit. Thus, these skills are often implemented according to the individual university's curricular constraints in the forms of coursework, apprenticeship, entrepreneurship, finishing school sessions, and mobility/internship, where, particularly in the non-coursework modes, these skills are subjectively assessed by taking into account the students' presence and/or involvement and asking lecturers to assess the students using holistic opinions (Othman, 2012). It comes as no surprise then that the whole issue of generic skills are generally treated as a trifling matter and sidelined in favor of the hard skills. It can be seen then, that in terms of the inculcation of the generic skills in higher education, there is a serious gap between what is intended and what is actualized. What is missing here is a sound screening tool to quantitatively assess graduating students' generic skills across the board in a

systematic and organized manner in order to provide an accurate picture of the students' actual employability. This conceptual paper seeks to suggest a model that would lead to such a screening tool.

The Stages in the Development of Graduate Employability Model

This section elucidates the developmental stages and procedures adopted in the construction of the Graduate Employability Model based on the configuration of the different phases of operation. To justify the premise under which the model will operate, the different phases in the construction of the model are clarified based on the relevancy of the stage in the development of the model.

Graduate Employability Model (GEM)

The Graduate Employability Model (GEM) is premised on a structured process of how a feasible generic skills test can be utilized as an exit screening test in universities. The construction of this model is graphically represented in Fig.1. The model is divided into four phases. The first phase may be referred to as Planning & Research. In this phase, literature review on generic skills and instruments that can be used to measure them is conducted. This however, may not correspond to the immediate needs of a nation or society. The research however is crucial to pinpoint and create a specific structure of criteria that can facilitate in identifying out the needs.

The second phase is the Needs Analysis. Using the information gathered in the Planning & Research phase, a questionnaire

is constructed to find out the specific needs of a society or nation. The questionnaire is then pilot tested and refined until it is suitable for distribution. Once the questionnaire has been finalized, it is distributed to three different groups of samples. First, is the employer sample as they would elucidate the immediate needs of the industry and working fields and their demands of fresh graduates' abilities and employability. Secondly, the questionnaire will be distributed among academic staff of HEIs as this information would serve as a foil to the actual needs of the employers. It may seem odd, but it may happen that what the university policy makers consider important may differ from what the employers require and they are the major stakeholder in higher education. Last but not least, the questionnaire will be distributed to undergraduates in order to

assess if they possess the skills demanded by both employers and the university.

Once the data from the questionnaire has been collated, it is analyzed and brought forward to the third phase, which is the Instrument Construction phase. This phase begins with the analysis of the data acquired from the questionnaires. The construction of the instrument is predicated on the needs derived from the survey data where the percentage, ratio and weightage of the skills measured in the instrument are based on the priorities as determined by the needs. Once the instrument has been constructed, it undergoes a pilot testing and refinement process as well to weed out irrelevant items. This would become the first screening instrumentation. It is suggested that this instrument be called the Graduate Employability Model which when shortened

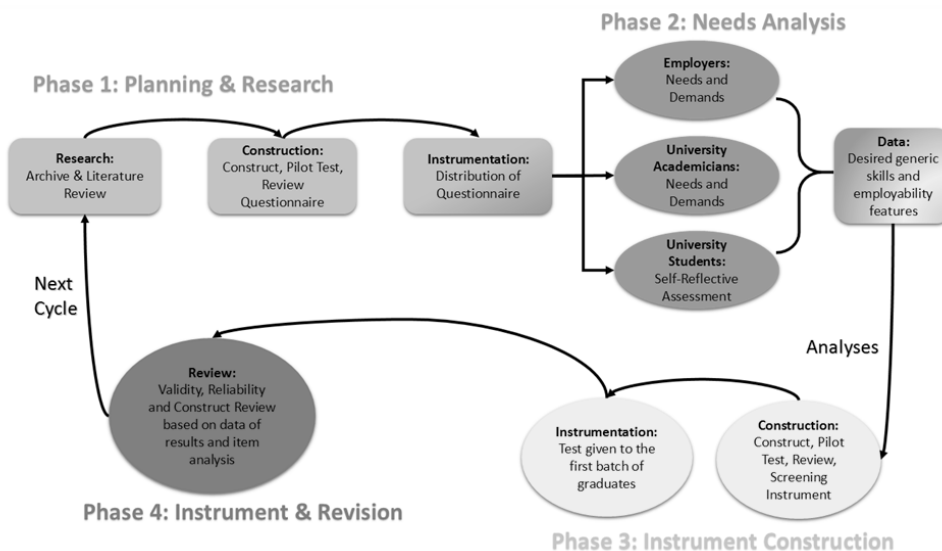

Fig. 1: Structured process of the construction of the Graduate Employability Model

is called GEM, an apt metaphor for the work ready graduates emerging as a consequence of being assessed through this model.

The last phase is the Instrumentation and Revision of the GEM assessment tool. This is to be administered to final year students who are about to graduate. The results obtained from this instrument would allow the university to gauge the graduating students' employability. Obviously, validity, reliability and construct review are strictly observed using item analyses to avoid any discrepancies occurring during the construction or data analyses process. The result of the analyses is then used to review and refine the format of the assessment tool and is included as an important consideration in the construction of instrument in the next cycle. The whole process, being cyclic in nature, is repeated in each cycle.

CONCLUSION

Once this model is up and running, it can be expected to generate a lot of research in terms of its efficacy and implementation. Research would be forthcoming on the actual performance of the graduates in the workplace as to whether they are living up to the assessment generated through this model. Employers would definitely have a lot to say regarding the efficacy of the model and the strengths and weaknesses that may emerge would be readily disclosed by them. HEIs and the Department of Higher Learning in the Malaysian Ministry of Education would be most interested to track the progress of the graduates who have been assessed through this model.

It is highly ambitious to expect the first run of the GEM assessment tool to be completely effective and flawless. Being a new model, there are bound to be hiccups in implementation which may necessitate some revision in the implementation or recalibration of the phases in order to rectify any weaknesses that (may) emerge. Realizing that unforeseen drawbacks may emerge, the model developers have designed it along a cyclical process framework, where it is open to constant and continuous upgrading. Still, such a model is inarguably necessary for a comprehensive assessment of graduate work-related competencies and having one that works fairly well, is much better than having none at all.

What is salient in this discussion is that while we still lack a systematic exit screening instrument that can effectively gauge our graduates' employability, many other countries have already embarked on this venture for a number of years. While meticulous and stringent screening measures are in place for university entrance, university exit appears to be lax specifically with regards to generic skills evaluation— which is to our mind, a far more crucial element to the graduates' success than their entrance to the university. In view of the worrying trends in graduate unemployment, it is timely that we begin to reflect upon, research, plan, survey, construct, and administer some sort of employability assessment tool to help us to rectify the shortcomings or enhance the quality of our graduates as they exit the university. At the end of the day, it doesn't

matter how many students graduated with a first class honors. What is more important is how many of them can contribute positively to their respective fields that would in the long run propel the nation's growth and development. When all is said and done, we must never forget that a university generates the nation's workforce and is thus beholden to cater to the needs of employers who are then, its clients.

REFERENCES

- Agus, A., Awang, A. H., Yussof, I., & Mohamed Makhbul, Z. K. (2011). The Gap Analysis of Graduate Employees' Work Skills in Malaysia. International Conference on Business and Information (BAI2012) (pp.1-15). Sapporo, Japan: Universiti Kebangsaan Malaysia (UKM).
- Asnida S. (2003). *Pengangguran Siswazah di Malaysia*. (Unpublished thesis for Master of Economics). University of Malaya: Kuala Lumpur.
- Bernama. (2012, March 13). *Education Transformation Needful To Create Thinking Generation – Najib*. Kuala Lumpur, Kuala Lumpur, Malaysia. Retrieved March 29, 2012, from <http://1malaysia.com.my/news/education-transformation-needful-to-create-thinking-generation-najib/>, pp.3.
- Brown, P., Hesketh, A., & Williams, S. (2002). *Employability in a Knowledge-Driven Economy*. Cardiff University, School of Social Sciences. Cardiff: Cardiff University.
- Chiam, T. H. (2005). *Employability and Learnability of Malaysian Graduates at the Work Place*. Paper presented at the 9th Malaysian Education Summit: World-Class Education in Malaysia: Creating a New Breed of Human Capital to Transform Malaysia into a Centre of Knowledge and Technology Excellence, Sunway Pyramid Convention Centre, Kuala Lumpur, 21-22 March 2005
- Department of Statistics, M. (2011). *Statistics of Graduates in the Labour Force Malaysia 2011*. Department of Statistics, Malaysia, Labour Force Survey. Putrajaya: Department of Statistics, Malaysia.
- Hambur, S., Rowe, K., & Luc, L. T. (2002). *Graduate Skills Assessment: Stage One Validity*. Canberra: Australian Council for Educational Research.
- Hampson, I., & Junor, A. (2010). Putting the process back in: Rethinking service sector skill. *Work, Employment and Society*, 24(3), 527-545.
- Hesketh, A. J. (2000). Recruiting an elite? Employers' perceptions of graduate education and training. *Journal of Education and Work*, 13(3), 245-271.
- Hillage, J., & Pollard, E. (1998). *Employability: Developing A Framework for Policy Analysis*. *Research Brief*, 85, 1-4
- Hinchliffe, G. (2002) Situating skills. *Journal of Philosophy of Education*, 36(2), 187-205.
- Holmes, L. (2001). Reconsidering graduate employability: the Graduate Identity approach. *Quality in Higher Education*, 7(2), 111-119.
- Gibbons, M. (2000). *Higher Education Relevance in the 21st Century*. Paper presented at the International Conference on Policy Issues in Higher Education in the New Millenium, Kuala Lumpur, 12-13 June.
- Knight, P. T., & Yorke, M. (2004). *Learning, curriculum and employability in higher education*. London: Routledge Falmer.
- Koo Y. L. (2007). Mindful PluriLiteracy (PL) For Multilingual Learners: Sustaining Diverse Cultures in Language and Literacy Education. In Ambigapathy Pandian, Koo Yew Lie, & Peter Kell. (Eds). *Innovation and Intervention in ELT: Pathways and Practices*. (pp. 201 - 223) Serdang: Universiti Putra Malaysia Press.

- Leon, P. (2002, November 22). Graduates say degrees leave them short of skills. *The Times Higher Education Supplement*, p.6.
- Md. Yunus, A. S., Abu, R., Mohd. Nor, S., Ahmad Tarmizi, R., Abu Bakar, K., Wan Ali, W. Z., Hamzah, R., Ismail, H. (2005). Generic Skills of Malaysian University Students. *Bulletin of Higher Educational Research*, 6, 5-6.
- Ministry of Higher Education, Malaysia (2007). *The National Higher Education Action Plan 2007-2010: Triggering Higher Education Transformation*. Putrajaya: Ministry of Higher Education Malaysia.
- Morley, L. (2001) Producing new workers: quality, equality and employability in higher education. *Quality in Higher Education*, 7(2), 131-138.
- Norshima Z. S. (2008). *Are graduates to be blamed? Unemployment of computer science graduates in Malaysia*. Retrieved 8 June 2009 from <http://aabss.org/journal2008AABSS2008Article6NORSHIMAZSHAH.pdf>.
- Norizan, A.R., A. Hazita, A.A.M. Sallehuddin, F.F. Wong and Y. Azizah (2006). *The Quality and Marketability Value of Local Graduates: Perspectives from the Malaysian Employers*. paper presented at the 6th SEAAIR Annual Conference, Langkawi, 5-7 September.
- Ong, P. H. (2006). *Soft Skills in Higher Education: The UNIMAS Medical Model*. paper presented at the 6th SEAAIR Annual Conference, Langkawi, 5-7 September.
- Orr, D. (1991). What is Education For? Six myths about the foundations of modern education, and six new principles to replace them. In Context: *A Quarterly of Humane Sustainable Culture*, 27(Winter (The Learning Revolution)), 52-55
- Othman, J. (2012). *A Nationwide Comparative Study between Private and Public University Students' Soft Skills*. IIUM, IREP, pp. 1-10.
- Pierce, D. (2002). Employability: higher education and careers services. Abridged version of a report prepared for AGCAS (mimeo).
- Purcell, K., & Elias, P. (2002). Seven years on... Making sense of the new graduate labour market. *Graduate Recruiter*, 8(October), 22-23.
- Saterfiel, T. H., & McLarty, J. R. (1995, January 30). *Assessing Employability Skills*. ERIC Digest. Retrieved February 23, 2012, from ERIC Digest: <http://www.ericdigests.org/1996-3/assessing.htm>
- Shyamal, M. (2009, September 16 - 18). *Emerging Generic Skills for Employability in the Knowledge Society*. Retrieved January 12, 2012, from Colombo Plan Staff College for Technical Education (cpsctech.org): <http://drupal.cpsctech.org/management/dg/sl/2-EMERGING%20GENERIC%20SKILLS.pdf>
- Sri Ramalu, S., Che Rose, R., Uli, J., & Kumar, N. (2010). Personality and Cross-Cultural Adjustment among Expatriate Assignees in Malaysia. *International Business Research Journal*, 3(4), 96-104.
- Stephenson, J. (1998). The concept of capability and its importance in higher education. In Stephenson, J. and Yorke, M. (Eds.) *Capability and quality in higher education* (pp.1-13) London: Kogan.
- The, H., & Pendergast, D. (2009). *Graduate and Employer Perspectives on Course Efficacy – A study of VET in a Developing Economy*. AVETRA - VET Research: *Leading and Responding in Turbulent Times* (pp. 1 - 19). Sydney: Australian Vocational Education and Training Research Association. Retrieved January 17, 2013, from http://www98.griffith.edu.au/dspace/bitstream/handle/10072/32854/57291_1.pdf?sequence=1. ISBN: 978-0-9805275-1-3.
- Thomas, T., Petocz, P., Rigby, B., Clark-Murphy, M., Daly, A., Dixon, P., Kavanagh, M., Lees, N. Leveson, L., & Wood, L. (2009). Embedding

- Generic Skills Means Assessing Generic Skills. Melbourne: Royal Melbourne Institute of Technology.
- TSA Cambridge Background & Research. (2008). Retrieved March 15, 2012, from Cambridge Assessment: <http://www.admissionstests.cambridgeassessment.org.uk/adt/tsacambridge/research>
- Turner, R. (2004). Towards a Structural Model Connecting Hard Skills, Soft Skills and Job Conditions and the IS Professional: The Student Perspective. *Issues in Informing Science and Information Technology, 1*, 977-991
- Wolf, A. (2002). *Does education matter? Myths about education and economic growth*. London: Penguin.
- Yassin, S., Abu Hasan, F., Amin, W., & Amiruddin, N. (2008). *Implementation of Generic Skills in the Curriculum*. EDU-COM International Conference (pp. 571-582). Perth: Edith Cowan University.
- Yorke, M. (2006). *Employability in Higher Education: What It Is - What It Is Not*. Heslington, York, United Kingdom: The Higher Education Academy United Kingdom.
- Yorke, M. and Knight, P. (Reprinted 2006). *Embedding employability into the curriculum*. York, Higher Education Academy.

Computer-Mediated Communication Use Among Adolescents and Its Implication for Psychological Need Satisfaction

Chin-Siang Ang^{1*}, Mansor Abu Talib¹, Jo-Pei Tan³ and Siti Nor Yaacob²

¹Department of Human Development and Family Studies, Faculty of Human Ecology, Universiti Putra Malaysia, 43400 UPM Serdang, Selangor, Malaysia

²Family, Adolescent and Child Research Centre of Excellent (FACE), Universiti Putra Malaysia, 43400 UPM Serdang, Selangor, Malaysia

³Department of Social Care and Social Work, Faculty of Health, Psychology and Social Care, Manchester Metropolitan University, United Kingdom

ABSTRACT

Online self-disclosure and online communication are two communication behaviours that, on the basis of prior research and theory, would appear to be related both to one another and to psychological need satisfaction. This study explored these relationships among a sample of 190 secondary school students drawn from a district in Malaysia. Respondents completed a questionnaire battery, which included measures of online self-disclosure, online communication and psychological need satisfaction. Quantitative data were then entered and analysed via Statistical Package for Social Sciences (SPSS). The results demonstrated that adolescents disclosed more during same-sex interaction than opposite-sex interaction. The findings also showed a positive relationship between online communication and same-sex disclosure for adolescent girls, but not necessarily for boys. Hierarchical regression analyses confirmed that for male and female adolescents, same-sex disclosure, opposite-sex disclosure and online communication were found to be predictive of adolescents' experiences of psychological need satisfaction in online friendships. No interaction effect was found between online self-disclosure and online communication on psychological need satisfaction. The contribution of this study is two-fold. First, currently, little research exists examining the association between online self-disclosure, online communication and

psychological need satisfaction in a single published study. Second, we extend previous research with a more nuanced understanding of psychological need satisfaction embedded in the context of CMC.

ARTICLE INFO

Article history:

Received: 10 April 2013

Accepted: 14 May 2014

E-mail addresses:

austin_ang119@hotmail.com (Chin-Siang Ang),

mansorat@upm.edu.my (Mansor Abu Talib),

j.tan@mmu.ac.uk (Jo-Pei Tan),

sitinor@upm.edu.my (Siti Nor Yaacob)

* Corresponding author

Keywords: Adolescents, Computer-Mediated Communication, Psychological Need Satisfaction, Self-Determination Theory, Uses and Gratification Theory

INTRODUCTION

Due to considerable technological advancements in networked computing, a variety of activities, arguably move towards being virtual. For decades, Computer-Mediated Communication (CMC) has garnered widespread research attention. According to Walther (1992), CMC refers to “a synchronous and asynchronous electronic mail and computer conferencing by which senders encode in text messages that are relayed from the senders’ computer to receivers” (p. 52). It functions as a medium to expand and create more social opportunities across geographical distance (Baym, 2010; Walther & Parks, 2002). Ironically, prior studies generally indicated that CMC is attached to stigmas, ostensibly because of the unwitting, naïve or careless use of the technology by some users (Whitty & McLaughlin, 2007). In earlier years, Turow’s (1999) work documented that computer-mediated relationships were not rewarding to its users, yet carry more risks of victimisation. In the same year, Young (1999) reported that the power of computer technology is overwhelming as it can turn users to become addicted zombies.

In the following years, CMC has even been demonised as causing people to become dispositionally depressed or lonely (Beard, 2002; Kraut *et al.*, 1998; Strivers, 2004; Yao-Guo *et al.*, 2006). Nevertheless,

Kraut *et al.*’s (2002) later works found that the increased CMC use decreased perceived loneliness and depression, and, at the same time, increased perception of social connectedness and well-being. While these findings are informative, judging by survey data and increasing anecdotal evidence, it is notable that the CMC user base appears to be on the rise (Nurullah, 2008; Lenhart *et al.*, 2010). More importantly, the adolescent population constituted a bigger fan base of CMC than other age populations. It seems that overly negative portrayals of CMC did not seem to impede the popularity of CMC among teenagers. Instead, CMC is becoming more prevalent, thanks to Twitter and Facebook (Lenhart *et al.*, 2010; McKenna *et al.*, 2002; Stafford *et al.*, 1999; Wolak *et al.*, 2003).

Based on Whitty and McLaughlin’s (2007) research, the discussion of online socialisation should not only be limited to its detrimental effects, but also to positive ramifications. To the best of our knowledge, research on psychological need satisfaction relating to CMC behaviours is an under-researched area, although a great deal of research has addressed psychological need as motives for CMC use (McKenna *et al.*, 2002; Wolak *et al.*, 2003). In fact, psychologists have long noted that a person’s behaviour perseverance is shaped by the level of satisfaction derived from an activity (Deci & Ryan, 1985; 2008; Sheldon & Gunz, 2009). People who derive satisfaction from an activity tend to re-engage in the same activity. Linking satisfaction to CMC, we argue that the prevalence of CMC use

would not be high if people did not acquire satisfaction from its usage. Following from this, we embarked on this study to investigate psychological need satisfaction in online friendships using a sample of adolescents and to examine CMC-related behaviours such as online self-disclosure and online communication. This study was carried out in the state of Selangor and involved 190 secondary school students who made up the respondents of this research. This paper is organised as follows: Introduction followed by theoretical and conceptual framework, research methodology, result findings and finally, a summary of the discussion.

THEORETICAL FRAMEWORK

Both Self-Determination Theory (SDT; Deci & Ryan, 1985; 2008) and Uses and Gratification Theory (UG; Katz, Blumler, & Gurevitch, 1974) are used to guide this research theoretically. Both theories have been applied in a variety of disciplines from psychology to media studies (Sheldon *et al.*, 2001; Papacharissi & Rubin, 2000; Ryan *et al.*, 2006; Sheldon & Gunz, 2009). SDT is primarily concerned the satisfaction of three psychological needs (Deci & Ryan, 1985; 2008; Sheldon *et al.*, 2001). These needs consist of: a) autonomy, which refers to human agency or volition for one's action and decision (b) competence, which refers to a sense of mastery and self-proficiency in order to interact effectively with one's world, and (c) relatedness, which refers to feelings of being cared for, liked and valued by other individuals. Satisfaction of these three needs is assumed to bring

about optimal well-being and psychological vitality. By contrast, poor health, depression and low self-esteem are expected to ensue if these needs are thwarted.

More significantly, all three needs are theoretically assumed to be universally required by every individual regardless of culture and context variability (Ryan & Deci, 2008; Ryan *et al.*, 2006; Sheldon *et al.*, 2001; Sheldon & Gunz, 2009). Perceived need satisfaction related to any behaviour can enhance individuals' willingness to strengthen that behaviour. Although psychological needs are important, the satisfaction of the psychological needs is by no means considered to be automatic. Instead, it is facilitated through one's social relationships and contexts (Deci & Ryan, 1985; 2008). Those who feel fulfilled in their social relationships have a better chance of experiencing psychological need satisfaction, while those who are left unfulfilled experience dissatisfaction. In this regard, humans are naturally inclined towards integration into the social matrix to acquire the satisfaction of these three psychological needs, which in turn, facilitates their well-being (Deci & Ryan 1985; 2002; Reeve, 2009).

Presently, it seems socialisation via CMC is a common practice (Wolak *et al.*, 2003; Lenhart *et al.*, 2010). By using it, people can get to know others, relate to them, learn from them and share with them without physical constraints (Baym, 2010; Walther & Parks, 2002). UG was thus incorporated to explain why people use media and what they use them for (Katz

et al., 1974). This theory posits that (1) the social and psychological origins of (2) needs which generate (3) expectations of (4) the mass media or other sources lead to (5) differential patterns of media exposure (or engagement in other activities), resulting in (6) need gratifications and (7) other consequences, perhaps mostly unintended ones” (Katz *et al.*, 1974, p. 510).

Specifically, UG assumes media use is purposive and motivated; therefore, users are active rather than passive consumers of media. Users often evaluate their available media options and should choose a medium that best fulfils their needs. Media choice, therefore, lies within the users’ capacity to meet desired outcomes or goals. This notion can be literally defined as ‘audience-centered,’ and prompts a research shift from “what media do to people” to “what people do with media” (Papacharissi & Rubin, 2000). It is noted that the degree of the users’ gratification obtained from the media exposure will contribute to the continuance of media use. Taken together, these two theories give a clear justification that individuals are always fully aware of what they are doing and proactive enough to ensure their needs are met while avoiding events or occasions that thwart need fulfilment. A blend of both theories lends a better explanation of the mechanics of the relationship examined in the present study than either theory does on its own.

LITERATURE REVIEW

Despite CMC’s growing popularity, relatively little is known about psychological

need satisfaction in the CMC context. The present study examines whether electronically mediated communication supports psychological need satisfaction of adolescents. In fact, there is some tentative evidence suggesting that CMC is provided with a sense of purpose, challenge and opportunities for self-fulfilment, each of which is potentially linked to psychological need satisfaction (Ryan *et al.*, 2006). Drawing on much evidence to date, it is not hard to find that people are not passively affected by technology, but are indeed, actively shaped its use (Hughes & Hans, 2001; McKenna *et al.*, 2002; Ryan *et al.*, 2006).

For example, some scholars found that CMC was highly interactive and flexible, enabling users to express the way they truly feel and think (Stafford *et al.*, 1999; Bargh *et al.*, 2002). The relative anonymity of cyberspace was also found to create a safer atmosphere in which users can be more liberal with their expressions (Ben-Ze-ev, 2003). People are thus allowed to exercise autonomous behaviours based on their desires without interference. This accommodates their increasing desire for autonomy. In some instances, CMC was seen to promote and facilitate one’s world as comprehensible, manageable and meaningful (Queensland University of Technology, 2008, July 17). The text-based nature of CMC was found to be beneficial for individuals to build Internet literacy and was probably accompanied by a feeling of competence. Further, its real time interactive feature also facilitated

communication of affection (Baym, 2010; Hardey, 2004). Walther and Parks (2010) and McKenna *et al.* (2000) believe that digitally enabled interaction allows people to have opportunities to interact with others who have similar interests, values and beliefs using both asynchronous and synchronous communication tools, such as email, instant messaging and social networking sites. The literature seems to suggest that there are three different aspects to psychological needs: autonomy, competence and relatedness, which are all attainable in the CMC context.

In explaining how people satisfy psychological needs from the online socialising practices, sociologists and psychologists have become interested in examining whether a relationship exists between online self-disclosure and online communication. From a sociological perspective, self-disclosure and time spent on communication in a social interaction are essential investments to develop close relationships (Derlega *et al.*, 1993; Morry, 2005). Typically, the relationship formation process requires individuals to increase self-disclosure and time commitment.

Based on Schouten *et al.* (2007), online self-disclosure refers to the extent to which the individual reveals information about himself to others over the Internet. Bargh *et al.* (2002) found that young people were more comfortable disclosing their inner world to their screen-life friends than to their real-life friends. The findings clearly revealed that one's "true self was more accessible in memory following an

interaction with a stranger over the Internet compared to after a face-to-face interaction" (p. 44). Ben-Ze-ev (2003) supports this viewpoint, suggesting that self-disclosure appears to be prevalent in online interactions because one feels more anonymous, distant and safe by hiding behind the screen, and potential rejection is less common in cyberspace. The act of disclosing more about oneself online heightens trust and intimacy, and in turn, increases relationship satisfaction. A longitudinal study also unanimously showed that young people who disclosed more of their true selves online were more likely to have close, long-lasting online relationships and ultimately, reported higher satisfaction derived from the relationships (McKenna *et al.*, 2002).

With respect to online communication, Bonetti *et al.* (2010) defined it as amount of time spent (i.e. frequency and duration) in communicating online. Research has found that the more the online communication, the greater the satisfaction reported (McKenna *et al.*, 2002). Another study also contended that greater frequency of interaction with online friends positively impacted psychological well-being (Bargh & McKenna, 2004). These findings may be attributable to the fact that conscious investment of time in social interactions results in relational closeness (Morry, 2005).

Still, gender gap exists on digital divides (e.g. amount of time online, self-disclosure online). For example, some studies reported that females tended to involve significantly more in online communication (Bonetti *et al.*, 2010; Lenhart *et al.*, 2010) and

placed greater emphasis on sharing true emotions than males (Cho, 2007; Schouten *et al.*, 2007). However, research findings are inconsistent across the studies. Some studies showed that males were more likely users of technology (Lenhart *et al.*, 2007; Subrahmanyam & Smahel, 2011) and were more likely to embrace the Internet (Kraut *et al.*, 1998) than females. Thus, males reported longer durations for communicating using the Internet (Jones, Johnson-Yale, Millermaier, & Pérez, 2009), and communicated online more frequently with people they had never met physically than females did (Soh *et al.*, 2013). Additionally, males generally showed higher levels of self-disclosure in their online interactions than did females (Barak & Gluck-Ofri, 2007; Subrahmanyam & Smahel, 2011) because males were traditionally encouraged to suppress their emotions and feelings. Therefore, they displayed greater courage by articulating their inner selves than females, who chose to remain anonymous. Based on existing research, we aimed to meet the following research objectives:

- i. To compare the levels of online self-disclosure, online communication and psychological need satisfaction between male and female adolescents
- ii. To examine the relationship between online self-disclosure, online communication and psychological need satisfaction for male and female adolescents

- iii. To identify factors predicting the psychological need satisfaction for male and female adolescents

METHOD

Sample

A survey was carried out among a sample of students in two secondary schools. Formal approval was obtained to carry out anonymous questionnaires. On the day of recruitment, a short, cover letter explaining the purpose of the research and a consent form were given to the respondents. Upon their agreement, respondents were asked to fill in the questionnaire. Of the 240 sets of the questionnaire sent to potential respondents, 200 were returned, out of which 10 were uncompleted, giving a response rate of 78.33%. To increase comprehension of the questionnaire among the respondents, the questionnaire had been previously translated into Malay using Brislin's method (for full review, see Willgerodt *et al.*, 2005). The pilot study of the translated version of the questionnaire showed good reliability.

Instrumentation

To collect respondents' demographic information, we asked questions about their gender, age, race, family monthly income, family size, number of sibling, parents' highest educational attainment, family structure and several general questions about online communication patterns.

Online self-disclosure was measured using Online Intimate Self-disclosure (OISD; Schouten *et al.*, 2007). Respondents

were asked to report their self-disclosure with a male friend and female friend with whom they most communicated online. This scale consisted of 7 items each for the male friend and female friend. Each item rated on a scale of 1 (*I tell nothing about this*) to 5 (*I tell everything about this*). Higher scores indicated higher self-disclosure online. Example of items included “*Thing I am worried about*” and “*Moments in my life when I feel guilty.*” The scale was good internally and consistent with this sample ($\alpha = .89$ for online self-disclosure to boys; $\alpha = .88$ for online self-disclosure to girls).

Online communication was measured using Online Communication Scale (OCS; Bonetti *et al.*, 2010). Respondents were asked to report the frequency and duration of communication virtually. This scale consisted of 4 items. One item rated on a scale of 1 (none) to 4 (every day), and three items rated on a scale of 1 (less than 15 minutes) to 4 (more than 4 hours). Z-score was thus to calculate and higher scores indicated higher involvement in online relationships. Example of items included “*How many days in the past week were you online to communicate/interact with online friends?*” and “*On the average weekend, approximately how long in total do you communicate/interact with online friends?*” The scale was good internally and consistent with this sample ($\alpha = .85$).

Psychological need satisfaction was measured using Need Satisfaction in Relationship Scale (NSRS; La Guardia *et al.*, 2000). Respondents were asked to report how satisfied they were in terms of

psychological needs in online friendship. This scale consisted of 9 items. Each rated on a scale of 1 (*not true at all*) to 7 (*very true*). Higher scores indicated higher satisfaction. Example of items included “*When I am with online friend(s), I feel free to be whom I am*” (autonomy), “*When I am with online friend(s), I feel like a competent person*” (competence), and “*When I am with online friend(s), I feel loved and cared about*” (relatedness). The scale was good internally and consistent in this sample ($\alpha = .89$).

Data Analysis

Using SPSS 18.0, descriptive statistics such as frequency, percentage, mean and standard deviation were used to describe demographic characteristics and study variables. An independent sample *t*-test was also computed to examine study variables between gender groups. Correlation analyses, on the other hand, was used to examine the relationship between the study variables. Hierarchical regression modelling was finally performed to assess the effect of online self-disclosure and online communication on psychological need satisfaction. An interaction effect between online self-disclosure and online communication was also included in the analyses. To reduce multicollinearity that may occur with interaction terms, all the continuous scores were centered on the respective sample mean prior to creating interaction terms (Cohen *et al.*, 2003). The level of significance in this study was .05.

To collect respondents’ demographic information, we asked questions about their

gender, age, race, family monthly income, family size, number of sibling, parents' highest educational attainment, family structure and several general questions about online communication patterns.

Online self-disclosure was measured using Online Intimate Self-disclosure (OISD; Schouten *et al.*, 2007). Respondents were asked to report their self-disclosure with a male friend and female friend with whom they most communicated online. This scale consisted of 7 items independently for the male friend and female friend. Each item rated on a scale of 1 (*I tell nothing about this*) to 5 (*I tell everything about this*). Higher scores indicated higher self-disclosure online. Example of items included "*Thing I am worried about*" and "*Moments in my life when I feel guilty.*" The scale was good internally consistent with this sample ($\alpha = .89$ for online self-disclosure towards boy; $\alpha = .88$ for online self-disclosure towards girl).

Online communication was measured using Online Communication Scale (OCS; Bonetti *et al.*, 2010). Respondents were asked to report the frequency and duration of communication virtually. This scale consisted of 4 items. One item rated on a scale of 1 (none) to 4 (every day), and three items rated on a scale of 1 (less than 15 minutes) to 4 (more than 4 hours). Z-score was thus to calculate and higher scores indicated higher involvement in online relationships. Example of items included "*How many days in the past week were you online to communicate/interact with online friends?*" and "*On the average weekend,*

approximately how long in total do you communicate/interact with online friends?"

The scale was good internally and consistent with this sample ($\alpha = .85$).

Psychological need satisfaction was measured using Need Satisfaction in Relationship Scale (NSRS; La Guardia *et al.*, 2000). Respondents were asked to report how satisfied they were in terms of psychological needs in online friendship. This scale consisted of 9 items. Each rated on a scale of 1 (*not true at all*) to 7 (*very true*). Higher scores indicated higher satisfaction. Example of items included "*When I am with online friend(s), I feel free to be whom I am*" (autonomy), "*When I am with online friend(s), I feel like a competent person*" (competence), and "*When I am with online friend(s), I feel loved and cared about*" (relatedness). The scale was good internally and consistent in this sample ($\alpha = .89$).

Data Analysis

Using SPSS 18.0, descriptive statistics such as frequency, percentage, mean and standard deviation were used to describe demographic characteristics and study variables. An independent sample *t*-test was also computed to examine study variables between gender groups. Correlation analyses, on the other hand, were used to examine the relationship between the study variables. Hierarchical regression modelling was finally performed to assess the effect of online self-disclosure and online communication on psychological need satisfaction. An interaction effect between online self-disclosure and online

communication was also included in the analyses. To reduce multicollinearity that may occur with interaction terms, all the continuous scores were centred on the respective sample mean prior to creating interaction terms (Cohen *et al.*, 2003). The level of significance in this study was .05.

RESULTS

Demography of Respondents

Table 1 presents the demographic profile of the sample. Of the total sample, 94 were males and 96 were females. Participants' ages ranged from 14 to 16 years, with a mean age of 14.78 years ($SD = .98$). Malay adolescents (50.5%) constituted a majority of the sample, followed by Chinese (36.8%) and Indian (12.6%). About 56% of the participants indicated that they lived in an urban area and the remaining 43.7% reported that they lived in suburban areas. The average for family size and number of siblings was 5.49 ($SD = 2.01$) and 3.14 ($SD = 1.83$) respectively. Most of the participants came from middle-class families (Median = RM2000). The educational level of the respondents' parents ranged from primary education to graduate school: 7.9% and 6.3% had attended primary school; 56.3% and 49.5% had attended secondary school; 22.1% and 23.2% completed the diploma/STPM level; 8.9% and 14.7% had university degrees; and 4.7% and 6.3% had obtained Master/PhD degrees, for mothers and fathers, respectively. Finally, about 93% of the participants reported that they lived with both biological parents, and the

remaining 7% either stayed with a single parent or step-parent.

Descriptive Analysis for Communication Platforms and Channels

Table 2 presents participants' communication platforms and channels. As can be seen, Social Network Sites were the most used channel ($n = 130$, 68.4%). The other 13% ($n = 24$) preferred Twitter. The remaining respondents either preferred Online Games Sites ($n = 22$, 11.6%), Instant Messaging, Email ($n = 6$, 3.2%) or Forum ($n = 2$, 1.1%). Using multiple responses scoring, 176 out of 190 participants (92.6%) subscribed to Social Network Sites during the survey time. The results are not surprising as Facebook is the most popular communication platform among young people due to its interactive nature to create a personal network and its entertainment activities that teens love (Lenhart *et al.*, 2010). Over half of the participants indicated that they had used Email (53.2%), Online Games Sites (52.1%) and Instant Messaging (50.5%) respectively. Approximately two-fifths of the respondents had used Twitter. Interestingly, only one-tenth of the respondents had used Forum.

Gender differences in Measures Used

Table 3 displays means and standard deviations of study variables for male and female sub-samples. Skewedness and kurtosis were first conducted to check the normality of data. Using a (± 3.0) criterion for skewedness and kurtosis, we found that all the measures were within the acceptable ranges, implying that normality assumptions

were not violated (Onwuegbuzie & Daniel, 2002). In addition, the *t*-test was used to compare the difference in self-disclosure, communication and psychological need satisfaction ratings among male and female

adolescents. On average, male adolescents scored higher male-friend disclosure ($M = 15.83, SD = 6.96$) than female counterparts ($M = 11.94, SD = 6.71$). This difference was statistically significant, $t(188) = 4.28, p <$

TABLE 1
Profile of Respondents ($N = 190$)

Variable	F	%	M (Med)	SD
Age			14.78	.98
Monthly household income *			(2000)	
Family size			5.49	2.01
Number of siblings			3.14	1.83
Gender				
Male	94	49.5		
Female	96	50.5		
Ethnicity				
Malay	96	50.5		
Chinese	70	36.8		
Indian	24	12.6		
Place of origin				
Urban	107	56.3		
Suburban	83	43.7		
Mother's academic qualification				
Primary school	15	7.9		
Secondary school	107	56.3		
Diploma/STPM	42	22.1		
Degree	17	8.9		
Master/PhD	9	4.7		
Father's academic qualification				
Primary school	12	6.3		
Secondary school	94	49.5		
Diploma/STPM	44	23.2		
Degree	28	14.7		
Master/PhD	12	6.3		
Family Structure				
Father and Mother	177	93.2		
Mother/Father only	9	4.8		
Father and step-mother/Step-father and mother	4	2.1		

Note. *F* = Frequency, % = percentage, *M* = Mean, *Med* = Median, *SD* = Standard deviation, *Min* = Minimum, *Max* = Maximum.

Variable with asterisk was calculated using median instead of mean as it is less affected by extreme observations in the dataset (Babbie, 2007).

.001. On the other hand, male adolescents scored lower female-friend disclosure ($M = 14.84, SD = 6.64$) than female adolescents ($M = 17.06, SD = 5.49$). This difference was also statistically significant, $t(188) = -2.29, p < .05$. However, neither online communication nor psychological need satisfaction was significant across the gender groups.

Pearson's Product Moment Correlation Coefficient on Study Variables for Male and Female Sub-Samples

As recorded in Table 4, all the correlations were moderate to strong in magnitude. Among the male sub-sample, psychological need satisfaction was related to same-sex disclosure ($r = .29, p < .01$), opposite-sex disclosure ($r = .41, p < .001$) and online communication ($r = .24, p < .05$).

TABLE 2
Profile of Participants' Online Communication Channels

Computer-mediated channel	F	%
Most used communication channel (Tick only one answer)		
Instant Messaging	6	3.2
Social Network Sites	130	68.4
Twitter	24	12.6
Email	6	3.2
Forum	2	1.1
Online Games Site	22	11.6
Currently used communication channel (Tick all that apply)		
Instant Messaging	96	50.5%
Social Networking Sites	176	92.6%
Twitter	77	40.5%
Email	101	53.2%
Forum	19	10.0%
Online Games Site	99	52.1%

Note. F = frequency, %= percentage

TABLE 3
Means and Standard Deviations of Measures by Gender

Variable	Males		Females		t-value
	Mean	SD	Mean	SD	
Disclose toward boy	15.83	6.96	11.94	6.71	4.28***
Disclosed toward girl	14.84	6.64	17.06	5.49	-2.29*
Online communication	.12	3.41	-.27	2.76	.87
Psychological need satisfaction	36.21	11.53	35.83	10.29	.23

* $p < .05$. ** $p < .01$. *** $p < .001$.

Also noteworthy was that the relationship between online communication and same-sex disclosure ($r = .13, p > .05$) and opposite-sex disclosure ($r = .12, p > .05$) were essentially uncorrelated. On the other hand, analyses of the female sub-sample indicated that psychological need satisfaction was positively correlated with same-sex disclosure ($r = .28, p < .01$), opposite-sex disclosure ($r = .30, p < .01$) and online communication ($r = .34, p < .01$). Online communication was positively related to same-sex disclosure ($r = .28, p < .01$), but unrelated to opposite-sex disclosure ($r = .18, p > .05$). It is notable

that same-sex disclosure was significantly and strongly correlated with opposite-sex disclosure across the male ($r = .51, p < .001$) and female sub-samples ($r = .60, p < .001$).

Determinants of Psychological Need Satisfaction

The data were finally analysed using hierarchical multiple regression analyses. As recorded in Table 5, the first of the analyses examined the main effects of online self-disclosure (same-sex and opposite-sex disclosure) and online communication on psychological need satisfaction for the male sub-sample. When looking solely at the

TABLE 4
Intercorrelation Matrix on Primary Variables for Male and Female Samples

Variable	1	2	3	4
1. Same sex disclosure	-	.60***	.28**	.28**
2. Opposite sex disclosure	.51***	-	.18	.30**
3. Communication	.13	.12	-	.34**
4. Need satisfaction	.29**	.41***	.24*	-

Note. Correlations above the diagonal are based on female sample (n = 96). Correlations below the diagonal are based on male sample (n = 94).

* $p < .05$. ** $p < .01$. *** $p < .001$.

TABLE 5
Online Self-Disclosure and Online Communication as Predictors of Psychological Need Satisfaction

Variable	Male Reports of Satisfaction				Female Reports of Satisfaction			
	β		R^2	ΔR^2	β		R^2	ΔR^2
	Step 1	Step 2			Step 1	Step 2		
Same-sex disclosure	.11*	.11*	.21	.21	.19*	.19*	.18	.18
Opposite-sex disclosure	.32**	.32**			.10*	.10*		
Online communication	.23*	.24*			.28**	.28**		
Same-sex disclosure X Online communication		-.15	.21	.00		.00	.18	.00
Opposite-sex disclosure X Online communication		.06				.00		

Note. Regression coefficients are presented in standardized unit.

* $p < .05$. ** $p < .01$. *** $p < .001$.

main effects, the results showed that same-sex disclosure ($\beta = .11, p < .05$), opposite-sex disclosure ($\beta = .32, p < .01$) and online communication ($\beta = .23, p < .05$) emerged as statistically significant predictors of psychological need satisfaction. That is, male adolescents who reported higher levels of self-disclosure and who spent more time on communication were more likely to have higher psychological need satisfaction. Self-disclosure to opposite-sex friends may be more powerful than that of same-sex disclosure and online communication. The overall regression model $F(3, 90) = 8.01, p < .01$ was significant and 21% of the variance in psychological need satisfaction was accounted for. However, there was no incremental change in R^2 from step 1 to step 2, suggesting that the interaction effect did not account for a significant proportion of the variance of the criterion variable after controlling for main effects. In the analyses of the female sub-sample, the findings revealed significant effects of same-sex disclosure ($\beta = .19, p < .05$), opposite-sex disclosure ($\beta = .10, p < .05$) and online communication ($\beta = .28, p < .01$) on psychological need satisfaction. That is, female adolescents who reported more self-disclosure and more time spent on communication tended to report greater psychological need satisfaction. Online communication may be more powerful than that of same-sex disclosure and opposite-sex disclosure. Together, the combined predictors explained for 18% of the variance in psychological need satisfaction, $F(3, 92) = 6.50, p < .01$. Similar to the male sub-

sample, no significant interaction effect and additional variance in psychological need satisfaction was found.

DISCUSSION AND CONCLUSION

Given that the use of CMC has dramatically increased across the globe, it is important to explore the benefits of socialising and making friends online (Nurullah, 2008; Lenhart *et al.*, 2010). In this article, we attempt to fill the gap in the literature by investigating the extent to which online communication, online self-disclosure and psychological need satisfaction are related to each other. This study reported five major findings: (a) there was a significant difference between the genders in online self-disclosure. Both male and female adolescents tended to self-disclose more in same-sex rather than in opposite-sex interaction; (b) both same-sex and opposite-sex disclosure online were significantly correlated with psychological need satisfaction, that is, adolescents who reported higher levels of same-sex disclosure and opposite-sex disclosure were more likely to demonstrate higher levels of psychological need satisfaction; (c) online communication positively influenced psychological need satisfaction regardless of gender differences, that is, adolescents who spent a greater amount of time communicating online had higher psychological need satisfaction; (d) online communication was positively correlated with same-sex disclosure for adolescent girls, but not necessarily for boys, that is, female adolescents who spent more time communicating online reported

higher tendency to reveal information about themselves to same-sex friends; and (e) same-sex, opposite-sex disclosure, and online communication uniquely explained the variance in psychological need satisfaction. Opposite-sex disclosure was the strongest predictor of psychological need satisfaction for male adolescents whereas online communication was the strongest predictor of psychological need satisfaction for female adolescents.

As the theories claim, social relationships and contexts are necessary to meet psychological need satisfaction (Deci & Ryan, 1985; 2008; La Guardia *et al.*, 2000). Given that technology evolves, individuals are more wired now than ever and ready to seek close relationships on the Internet (Bargh *et al.*, 2002; McKenna *et al.*, 2002). A great deal of literature documents that CMC has become a salient social phenomenon and the concept of being “always connected” has become an embedded feature of modern life (Walther, 1992; Walther & Parks, 2002). Individuals are always aware of their media use and proactive enough to meet psychological gratifications that they desire from CMC experiences (Papacharissi & Rubin, 2000). In support of this view, findings from the current study indicated that adolescents who not only spent more time on online communication, but who also self-disclosed more elicited more gratification through mediated communication. The possible explanation is that more personal information-sharing and time spent communicating foster genuine and intimate

relationships and ultimately help to achieve psychological need satisfaction in online friendships (Bonetti *et al.*, 2010; Schouten *et al.*, 2007). Unfortunately, we are unable to test these potential explanations or whether the perception of “genuine and intimate relationships” mediates the aforementioned relationships. Future research in this area is warranted.

This study provided two major contributions to existing research. First, currently little research exists examining the association between online self-disclosure, online communication and psychological need satisfaction in a single published study. Second, none focuses specifically on psychological need satisfaction in the CMC context. These results provide initial evidence for the links between online communication, online self-disclosure and psychological need satisfaction by surveying a Malaysian sample. The study nevertheless has its limitations. Because we studied a relatively small number of students, our results may not be generalised to all adolescents who currently engage CMC. Small sample, sample bias, self-reporting nature and analyses that require more statistical power to administer were limitations in this study. Therefore, a more heterogeneous sample is called for in future research in order to run more powerful analyses.

Despite these limitations, the findings suggest that computer-mediated interactions may not be as negative as many assume. Surprisingly, today’s younger generation tends to perceive CMC as a need-satisfier.

This is counter to public perception that often views CMC as putting people at risk of different types of victimisation. This is not to say that physical social relationships do not provide psychological need satisfaction to adolescents (Deci & Ryan, 1985, 2008), but only to highlight that these needs are achievable in virtual environments as well. In other words, psychological need satisfaction is of fundamental importance regardless whether it is achieved through offline or virtual means. If adolescents are satisfied with their psychological need in online relationships, then rationally, adolescents should have no reason to not engage in computer-mediated communication. Hence, the present study may shed some light on the popularity of social media.

REFERENCES

- Babbie, E. R. (2007). *The practice of social research* (12th ed.). United States of America: Cengage Learning.
- Barak, A., & Gluck-Ofri, O. (2007). Degree and reciprocity of self-disclosure in online forums. *CyberPsychology & Behavior, 10*(3), 407-417.
- Bargh, J. A., & McKenna, K. Y. A. (2004). The Internet and social life. *Annual Review of Psychology, 55*, 573-590.
- Bargh, J. A., McKenna, K. Y. A., & Fitzsimons, G. M. (2002). Can you see the real me? Activation and expression of the “true self” on the Internet. *Journal of Social Issues, 58*(1), 33-48.
- Baym, N. K. (2010). *Personal connections in the digital age*. Cambridge, UK: Polity Press.
- Beard, K. W. (2002) Internet addiction: Current status and implications for employees. *Journal of Employment. Counseling, 39*(2), 2–11.
- Ben-Ze-ev, A. (2003). *Love online: Emotions on the Internet*. Cambridge. UK: Cambridge University Press.
- Bonetti, L. Campbell M. A., & Gilmore, L. (2010). The relationship of loneliness and social anxiety with children’s and adolescents’ online communication. *CyberPsychology, Behavior, and Social Networking, 13*(3), 279-285.
- Cho, S. H. (2007). Effects of motivations and gender on adolescents’ self-disclosure in online chatting. *CyberPsychology & Behavior, 10*(3), 339-345.
- Cohen, J., Cohen, P., West, S. G., & Aiken, L. S. (2003). *Applied multiple regression/correlation analysis for the behavioral sciences* (3rd ed.). Hillsdale: Erlbaum.
- Deci, E. L., & Ryan, R. M. (1985). *Intrinsic motivation and self-determination in human behavior*. New York: Plenum.
- Deci, E. L., & Ryan, R. M. (2008). Facilitating optimal motivation and psychological well-being across life’s domains. *Canadian Psychology, 49*(1), 14-23.
- Derlega, V. J., Metts, S., Petronio, S., & Margulis, S. T. (1993). *Self-disclosure*. Newbury Park, CA: Sage.
- Hardey, M. (2004) Mediated relationships: Authenticity and the possibility of romance. *Information, Communication & Society, 7*(2), 207-222.
- Hughes, R., Jr., & Hans, J. D. (2001). Computers, the Internet, and families. A review of the role new technology plays in family life. *Journal of Family Issues, 22*(6), 776-790.
- Jones, S., Johnson-Yale, C., Millermaier, S., & Pérez, F. S. (2009). U. S. College students’ internet: Race, gender, and digital divides. *Journal of Computer-Mediated Communication, 14*(2), 244-264. doi: 10.1111/j.1083-6101.2009.01439.x
- Karcher, M. J. (1999). *The Hemingway—Measure of Adolescent Connectedness: A manual for*

- interpretation and scoring*. Unpublished manual, University of Wisconsin-Madison.
- Katz, E., Blumler, J. G., & Gurevitch, M. (1974). Uses and gratification research. *The Public Opinion Quarterly*, 37(4), 509-523.
- Kraut, R., Kiesler, S., Boneva, B., Cummings, J., Helgeson, V., & Crawford, A. (2002). Internet paradox revisited. *Journal of Social Issues*, 58, 49-74.
- Kraut, R., Patterson, M., Landmark, V., Kiesler, S., Mukophadhyay, T., & Scherlis, W. (1998). Internet paradox: A social technology that reduces social involvement and psychological wellbeing? *American Psychologist*, 53, 1017-1031.
- La Guardia, J. G., Ryan, R. M., Couchman, C. E., & Deci, E. L. (2000). Within-person variation in security of attachment: A self-determination theory perspective on attachment, need fulfillment, and well-being. *Journal of Personality and Social Psychology*, 79, 367-384.
- Lenhart, A., & Madden, M. (2007, April 18). Teens, privacy and online social networks. *Pew Internet and American Life Project Report*. Retrieved January 9, 2012 from http://www.pewinternet.org/pdfs/PIP_Teens_Privacy_SNS_Report_Final.pdf
- Lenhart, A., Purcell, K., Smith, A., Zickuhr, K. (2010, February 3). Social media and young adults. *Pew Internet and American Life Report*. Retrieved January 9, 2012, from <http://www.pewinternet.org/2010/02/03/social-media-and-young-adults/>
- McKenna, K. Y. A., Green, A. S., & Gleason, M. E. J. (2002). Relationship formation on the Internet: What's the big attraction? *Journal of Social Issues*, 58, 9-31.
- Morry, M. M. (2005). Allocentrism and friendship satisfaction: The mediating roles of disclosure and closeness. *Canadian Journal of Behavioural Science*, 37(3), 211-222.
- Nurullah, A. S. (2008). Exploring cyberfriendship formation among Malaysian youth. *Journal of Communication Studies*, 1(3-4), 217-235.
- Onwuegbuzie, A. J., & Daniel, L. G. (2003, February 12). Typology of analytical and interpretational errors in quantitative and qualitative educational research. *Current Issues in Education*, 6(2). Retrieved from <http://cie.ed.asu.edu/volume6/number2/>
- Papacharissi, Z., & Rubin, A. M. (2000). Predictors of internet use. *Journal of Broadcasting & Electronic Media*, 44, 175-196.
- Queensland University of Technology (2008, July 17). Second Life improves real-life social skills. *Science Daily*. Retrieved February 10, 2012.
- Ryan, R. M., Rigby, C. S., & Przybylski, A. K. (2006). Motivation pull of video games: A Self-determination theory approach. *Motivation and Emotion*, 30, 347-365.
- Schouten, A. P., Valkenburg, P. M., & Peter, J. (2007). Precursors and underlying processes of adolescents' online self-disclosure: Testing an "Internet-Attribute-Perception" model. *Media Psychology*, 10, 292-315.
- Sheldon, K. M., Elliott, A. J., Kim, Y., & Kasser, T. (2001). What is satisfying about satisfying events? Testing 10 candidate psychological needs. *Journal of Personality and Social Psychology*, 80, 325-339.
- Sheldon, K. M., & Gunz, A. (2009). Psychological needs as basic motives, not just experiential requirement. *Journal of Personality*, 77, 1467-1492.
- Soh, P. C.-H., Teh, B. H., Hong, Y. H., Ong, T. S., & Charlton, J. P. (2013). Exploring gender differences in Malaysian urban adolescent Internet usage. *First Monday*, 18(9), available at <http://firstmonday.org/ojs/index.php/fm/article/view/4334/3745>

- Stafford, L., Kline, S. L., & Dimmick, J. (1999). Home e-mail: Relational maintenance and gratification opportunities. *Journal of Broadcasting & Electronic Media*, 43(4), 659-669.
- Stivers, R. (2004) *Shades of loneliness: Pathologies of a technological society*. Lanham: Rowman & Littlefield Publishers.
- Subrahmanyam, K., & Smahel, D. (2011). *Digital youth: The role of media in development*. New York: Springer.
- Turow, J. (1999, May 4). *The Internet and the family: The view from the parents, the view from the press* (Report No. 27). Philadelphia: Annenberg Public Policy Center of the University of Pennsylvania. Retrieved August 23, 2001, from <http://www.appcpenn.org>
- Walther, J. B. (1992). Interpersonal effects in computer-mediated interaction: A relational perspective. *Communication Research*, 19(1), 52-90.
- Walther, J. B., & Parks, M. R. (2002). Cues filtered out, cues filtered in: Computer-mediated communication and relationships. In M. L. Knapp & J. A. Daly (Eds.), *Handbook of interpersonal communication* (3rd ed., pp. 529–563). Thousand Oaks, CA: Sage.
- Willgerodt, M., Kataoka-Yahiro, M., Kim, E., & Ceria, C. (2005). Issues of instrument translation in research on Asian immigrant population. *Journal of Professional Nursing*, 21(4), 231-239.
- Whitty, M. T., & McLaughlin, D. (2007). Online recreation: The relationship between loneliness, internet self efficacy and the use of the Internet for entertainment purposes. *Computer in Human Behavior*, 23(3), 1435-1446.
- Wolak, J., Mitchell, K. J., & Finkelhor, D. (2003). Escaping or connecting? Characteristics of youth who form close online relationships. *Journal of Adolescence*, 26, 105-119.
- Yao-Guo, G., Lin-Yan, S. & Feng-Lin, C. (2006). A research on emotion and personality characteristics in junior high school students with internet addiction disorders. *Chinese Journal of Clinical Psychology*, 14, 153-155.
- Young, K. (1999). The research and controversy surrounding internet addiction. *Cyber Psychology and Behavior*, 2, 381–383.



Human Governance and Firm's Leverage Decision: Evidence from Malaysian Listed Companies

Irene Wei Kiong Ting^{1*}, Noor Azlinna Azizan² and Qian Long Kweh³

¹*Department of Finance and Economics, Universiti Tenaga Nasional, 26700 Muadzam Shah, Pahang, Malaysia*

²*Faculty of Technology, Universiti Malaysia Pahang, 26300 Gambang, Pahang, Malaysia*

³*Department of Accounting, Universiti Tenaga Nasional, 26700 Muadzam Shah, Pahang, Malaysia*

ABSTRACT

This paper examines the firm's leverage decision from a new perspective, namely human governance. The sample covers 110 public listed companies in Bursa Malaysia for the period of 2002 to 2011. The objective of this study is to investigate the influences of human governance, namely CEO's attributes (age, founder, tenure, duality, and gender) on a firm's leverage decision through OLS regression models. The moderating effect of CEO ownership on the association between CEO personal characteristics and leverage was evaluated. From the analysis a negative relationship between CEO age, founder, gender and leverage decision and a positive impact between tenure and leverage decision was discovered. The study also shows that CEOs owning shares in a company will more likely to take risks. The conclusion suggests that companies may increase their CEO share holdings so that CEO will align their personal interest with the ultimate goal of a company.

Keywords: Human governance, leverage decision, Malaysia listed companies

INTRODUCTION

The recent decades have seen growing importance placed on research in the issue of capital structure and its determinants.

Since the seminal work by Modigliani and Miller (1958), three major theories have emerged: the Trade off theory (TOT), the Pecking Order Theory (POT) and the Market Timing Theory (MTT). For at least the last 10 years, researchers have devoted significant effort in examining the importance of i) firm structure, ii) ownership structure and iii) corporate governance in explaining the firm's leverage decision. The focus of most empirical work has been on

ARTICLE INFO

Article history:

Received: 6 June 2013

Accepted: 12 September 2013

E-mail addresses:

irene@uniten.edu.my (Irene Wei Kiong Ting),

azlinna@ump.edu.my (Noor Azlinna Azizan),

qlkweh@uniten.edu.my (Qian Long Kweh)

* Corresponding author

market, industry, and firm characteristics. Overall, the results of prior studies prove that firms that are similar in terms of these fundamentals often choose very different corporate leverage. Despite a great deal of interest by previous researchers on the determinants mentioned above in leverage decision, there is surprisingly little empirical evidence linking other potential determinants, particularly from the human point of view. Zwiebel (1996) states that decision of capital structure is voluntarily chosen by the manager. Hasan (2009) argues that corporate governance is a mechanism that entails processes and structure that facilitate the creation of shareholder value through management of the corporate affairs in such a way to ensure the protection of the individual and collective interests of all the stakeholders. While considerable attention has been paid in the past to research issues related to the corporate governance mechanism (Daily, Dalton, and Cannella, 2003), literature on issues of the human role or leadership in helping a corporation realize its potential has emerged only very slowly and in a more scattered way (Salleh, Ahmad, & Kumar, 2009).

Although growing numbers of researchers have considered leadership, this topic remains highly relevant today with the reformation of the traditional economy. Economic growth and structural changes raise new issues concerning the leadership role in a firm's decision making. During the economic reformation, the leader of a firm plays a crucial role in a firm's leverage decision. In other words,

the leader's ownership might provide a control mechanism to discipline the management's self-interest behaviour more in line with the company's objectives, hence improving the performance. Cronqvist, Makhija, and Yonker (2012) state that several researchers have recently taken the position that differences in terms of personal preferences across CEOs may eventually impact firms' capital structure decisions. Blockholders with high control motivations would definitely prefer to choose external financing and maintain their authority in a firm's decision. Indeed, financial economists have recently examined some observable CEO characteristics as potential determinants of corporate leverage. This implies that it is important to know the effect of CEOs characteristics towards the capital structure in order to make strategic decisions. Thus, this study believes that there should be an association between leadership personal attributes (various types of human characteristics) and a firm's leverage decision.

Jensen and Meckling (1976) point out the divergence of interests between managers and shareholders of firms with dispersed ownership structure in an agency problem. They conclude that separation between ownership and control in company creates agency conflicts. Berger, Ofek, and Yermack (1997b) explain empirically that entrenched managers who are not effectively disciplined by governance mechanism prefer lower debt ratios. Friend and Hasbrouck (1988) further explain that managers have their own personal agenda

in firms in ways that benefit themselves personally. With this opportunistic behavior, managerial insiders will tend to avoid taking any risk due to their personal wealth. One of the options is to use less optimal amount of debt in order to reduce the bankruptcy risk. Fosberg (2004) agrees that agency problems arise because managers have the opportunity to use assets of the firm in ways that benefit themselves personally but decrease the wealth of the firm's shareholders. Kim, Rhim, and Friesner (2007) pointed out a crucial issue for a firm's shareholder on how to induce management to make decisions that maximize shareholder wealth while minimizing agency costs. One alternative to increase a blockholder's control and reduce agency costs is through increasing debt.

Many researchers discussed the relationship between CEO ownership and debt financing, but little has been done in the Malaysian context. Prior researches that investigated debt financing focused on various areas (i) political connection (Fraser, Zhang, and Derashid, 2006; Gomez, 2002; Johnson and Mitton, 2003); (ii) theories comparison (TOT vs POT) (Suhaila and Wan Mahmood, 2008; Yau, Lau, and Liwa, 2008); (iii) firm characteristics (Pandey, 2004); (iv) ownership structure (Suto, 2003). However, no studies empirically examine the capital structure of human governance in Malaysia. Thus, this paper attempts to bridge the gap and shed some lights to the literature. This study extends prior researches in this area by investigating the impact of CEO personal characteristics on leverage decision in Malaysia. Furthermore, the paper wishes to evaluate the interaction effect between

CEO personal characteristics and their share holdings on a firm's leverage decision. With that, we hope to provide some relevant information to the market players on the accountability and transparency of Malaysian listed firms in validating their firm leverage decision. In other words, it is important for Malaysian listed companies' shareholders to identify the consequences of CEO intervention through ownership.

This paper makes several contributions to the literature. First, this study uses a larger data sample and a longer study period than the previous studies in the literature. Second, the sample is divided into two groups, without CEO ownership and CEO ownership, in order to make a further comparison on the influence of CEO personal characteristics from a human governance point of view. Third, the paper also makes a methodological contribution. This study improves from the prior researches by employing different methods (pooled regression, fixed effects or separate regression tests) for the analysis. Fourth, the paper presents fresh evidence on the interaction between CEO personal characteristics and CEO ownership in affecting a firm's leverage. It is hoped that the findings of this study can serve as an indicator in assessing the impact of human governance on a firm's leverage decision.

The remainder of this paper is organized as follows: Section 2 reviews the literature. Section 3 records the data and methodology while Section 4 shows the empirical findings and discussions. Finally, a conclusion and recommendation are presented in Section 5.

LITERATURE REVIEW & HYPOTHESES DEVELOPMENT

CEO Age and leverage

Richard and Shelor (2002) agree that age changes an individual's perspective, belief systems and network. Vroom and Pahl (1971) further explain that older managers tend to be more risk averse whereas young managers are more willing to undertake risky innovative growth strategies.

Therefore,

H₁: CEO age will be significantly negative related to a firm's leverage decision.

CEO Founder and leverage

A CEO is believed to have greater personal identification with and commitment to the firm, as well as a higher level of trust from the firm's employees than a nonfounder-CEO. Fischer and Pollock (2004) claim that the CEO founder's involvement in the growth and success of a firm since its perception may motivate the CEO to derive the benefits of a firm.

Therefore,

H₂: The presence of a founder-CEO will be significantly positive related to firm's leverage decision.

CEO tenure and leverage

Other than ownership percentages, tenure is another important attribute to describe CEO characteristics as tenure reflects CEO experience and affects their level of risk aversion. Murphy (1999) shows that CEO

tenure is negatively related to performance. They argue that as CEO experience with the firm increases, the boards of directors have more opportunities to observe CEO behaviors over time such that they can assess CEO productivity more accurately. Moreover, Berger, Ofek, and Yermack (1997a) argue that CEOs with longer tenures are more likely to avoid risk. The results indicate that if a CEO services a firm longer, he may become more conservative and inclined to borrow less. This result is further supported by the finding of Bertrand and Schoar (2003). The authors found that older generations of managers, on average, are financially more conservative. They find that executives' risk aversion is positively correlated with their age (positively related to tenure) and firm leverage is negatively related to executives' age. For instance, Abor (2007) found that there is a negative relationship between the tenure of the CEO and capital structure, suggesting that, entrenched CEOs employ lower debt in order to reduce the performance pressures associated with high debt capital.

Therefore,

H₃: There is a significantly negative relationship between the CEO tenure and a firm's leverage decision.

CEO duality and leverage

Besides that, many previous studies also look into CEO/Chair duality and they believe that it is also one of the important features to describe CEO characteristics.

Morck, Shleifer, and Vishny (1988) argue that the role of CEO and chairman should be separate, as the CEO is the chief decision management authority and the chairman is the chief decision control authority. Fosberg (2004) suggests that a dual leadership structure is effective in increasing the amount of debt in a firm's capital structure. However, Abor (2007) concluded that there is a positive relationship between CEO duality and capital structure. Almeida, Ferreira, and Adams (2005) report that if a CEO is also the chairman of the board of directors, the powerful CEO tends to choose more aggressive capital structure. The result implies that as CEOs become more entrenched, they are more likely to take risk.

Therefore,

H₄: There is a significantly positive relationship between CEO duality and a firm's leverage decision.

CEO gender and leverage

Apart from CEO duality, gender is another main variable to describe the characteristics of CEO. Coleman and Cohn (2000) find that there are no significant differences in the usage of debt between men and women, and gender is not a significant predictor of financial leverage. In contrast, Abor (2007) argues that women-owned businesses are less likely to use debt for a variety of reasons, including discrimination and greater risk aversion. The result is consistent with Faccio, Marchica, and Murac (2012) who agree that firms run by female CEOs have lower leverage, less volatile earnings, and a

higher chance of survival than firms run by male CEOs. Moreover, Heminway (2007) argues that women are more trustworthy than men, and are thereby less likely to manipulate corporate financial and other disclosures.

Therefore,

H₅: Male CEOs prefer more debt.

DATA AND METHODOLOGIES

Sample Selection

This study is conducted by collecting the secondary data from Bursa Malaysia and other variables from DataStream. Of the 831 companies listed on the Main Board of Bursa Malaysia as at 3 September 2012, we managed to collect data for 793 companies after excluding the financial sector. From the 793 companies, we found only 310 companies with data available from 2002 to 2011. Further, we excluded the companies which lack data such as CEO information, firm size, etc. based on DataStream. At last, we managed to finalize 110 public listed companies from 7 sectors (Plantation, property, consumer, construction, trading and service, technology and industrial product) for 10-years period with full data available.

Variables and Measurement

As in Table 1

Research Model

$$\text{LEVE}_{it} = \alpha_0 + \alpha_1 \text{HG}_{it} + \delta' \text{CONTRL}_{it} + \varepsilon_i \quad (1)$$

TABLE 1
Variable measurement

Variables	Description	Prediction
<i>Explanatory variables</i> (Human governance-HG)		
CEO Age(CEOA)	The numeric variable expressing age of an executive adjusted by year.	-
CEO-Founder (CEOF)	Dummy variable which code as 1 if the founder of the company is CEO at the time and 0 otherwise.	+
CEO Tenure (CEOT)	Number of years in CEO position for firm.	-
CEO duality (DUA)	A dummy variable, 1 = if CEO is chairman, 0 = is otherwise	+
CEO gender (GEN)	A dummy variable 1 = if firm male-owned, 0 = is otherwise	+
<i>Moderating variable</i>		
CEO Ownership (CEOOW)	Percentages of shares owned directly by CEO	
<i>Control variables</i>		
Return on Assets (ROA)	Net Income divided by Total Assets	
Size (SIZE)	The natural log of total assets	
Board independence (BIND)	Number of independent non-executive directors	
Board Size (BSIZE)	Number of directors	
Dependent variables		
Leverage (LEVE)	Total debts to total assets	

where α_0 is the constant term of equation 1. α_1 as coefficients of the independent variables. δ as coefficients of the control variables. ϵ_{it} is the error term. Subscript i and t in equation 1 represent the firm and time, respectively. In this case, i represents the cross-section dimension and t represents the time series component.

LEVE is a measure of capital structure namely leverage. It is common to only use total debts to measure capital structure in analysing leverage antecedents (Ting and Lean (2011)). CONTRL is a vector of control variables including ROA (a measure of return on assets), SIZE (a measure of size), BIND (a measure of board

independence) and BSIZE (a measure of board size).

$$\begin{aligned} LEVE_{it} = & \beta_0 + \beta_1 HG_{it} + \beta_2 CEOOW_{it} \\ & + \beta_3 (HG_{it} \times CEOOW_{it}) \\ & + \delta' CONTRL_{it} + \epsilon_{it} \end{aligned} \quad (2)$$

Equation 2 is designed to evaluate the interaction effect between CEO personal characteristics and CEO ownership in affecting a firm's leverage. CEOOW is a measure of CEO ownership. It is measured as percentages of shares owned directly by CEO.

EMPIRICAL RESULTS

Descriptive Statistics

The following Table 2 provides the descriptive statistics for both companies with CEO ownership and companies without CEO ownership. Companies with CEO ownership account for approximately 71.8 percent of the total sample companies. The findings for difference-in-means tests are summarized as follows. CEOs with ownership are significantly elder than those without ownership. Moreover, most of the CEOs with ownership are founders of the companies, as compared to CEOs without ownership. The average tenure of CEO with ownership is about 15.907 years, which is significantly longer than that of CEO without ownership (10.764 years). Moreover, CEOs with ownership have a significantly higher percentage of the combination of Chairman and CEO positions than those without ownership. From the findings, it is known that most of the CEOs are male. In terms

of the control variables, only a significant difference between the mean of SIZE was found. In summary, statistically significant differences on the main testing variables between companies with CEO ownership and companies without CEO ownership were found. However, the univariate test is weak in that it does not control the variables used simultaneously in an empirical model. Therefore, a multivariate regression analysis was run to provide a more robust test to evaluate whether CEO ownership strengthens the relationship between leaders' attributes and the level of leverage.

To determine whether differences in leverage exist among the various industries (Plantation, Property, Consumer, Construction, Trading/Services, Technology, and Industrial Product), a non-parametric statistical analysis (Kruskal–Wallis test) was used. Table 3 lists the results. The findings show that companies in the trading or services industry have the highest mean

TABLE 2
Descriptive statistics of independent variables

	With CEO Ownership (N = 797 firm-year observations)		Without CEO Ownership (N = 313 firm-year observations)		Difference in Means (<i>t</i> -stat)
	Mean	S.D.	Mean	S.D.	
CEOA	52.966	7.746	50.655	9.091	-4.253***
CEOF	0.319	0.466	0.118	0.323	-6.976***
CEOT	15.907	9.525	10.764	9.861	-8.015***
DUA	0.280	0.449	0.166	0.373	-3.972***
GEN	0.991	0.106	0.971	0.167	-2.370**
ROA	0.052	0.116	0.053	0.145	0.120
SIZE	12.197	1.376	12.642	1.669	4.552***
BIND	0.425	0.108	0.430	0.117	0.650
BSIZE	7.493	1.822	7.419	1.855	-0.610

Note: *, **, and *** denote the statistical significance at the 10%, 5%, and 1% level, respectively.

TABLE 3
Test of difference on the dependent variable

Industry	Leverage (The ratio of total debts to total assets)							Overall
	1	2	3	4	5	6	7	
Mean (Median)	0.383 (0.305)	0.455 (0.473)	0.436 (0.414)	0.431 (0.392)	0.467 (0.454)	0.465 (0.391)	0.473 (0.434)	0.457 (0.434)
Kruskal-Wallis teststatistic	12.657**							

Note: 1 to 7 represent the plantation industry, the property industry, the consumer industry, the construction industry, the trading/services industry, the technology industry, and the industrial product industry, respectively.

(median) leverage of 0.467 (0.454). This could be because the sector has the highest average total liabilities, long term liabilities and short term liabilities, and followed by those companies from Construction and Property sectors which is consistent with Mustapha and Ismail (2011).

The Relation between Human Governance and Performances

Before the final OLS regression was performed, some diagnostic tests were carried out. First, the diagnostic of variance inflation factors (VIF) was conducted but no evidence of collinearity among the variables in our regression models was found.¹ Second, a check for heteroskedasticity of residuals in Equations (1) and (2) using White test (White, 1980) was done. The results suggest (White, 1980) that heteroskedasticity-consistent standard errors to report our significance levels be used.

Table 4 presents the OLS regression results. The two equations are statistically significant with F-statistics of 22.683 and

¹ VIF values: CEOA = 1.687, CEOF = 1.826, CEOT = 1.704, DUA = 1.723, GEN = 3.160, ROA = 1.523, SIZE = 2.016, BIND = 2.704 and BSIZE = 1.802

15.104, respectively. The results of Equation (1) show that the coefficient on CEOA is negative and statistically significant, suggesting that elder CEOs tend to be more risk averse and thus taking less debt. This finding supports our hypothesis. Of the main variables, we also find statistically significant and negative coefficients on CEOF and GEN. These results imply that founder-CEOs may also avoid risk to benefit themselves. Furthermore, nonfounder firms benefits from greater monitoring which presumably leads the firm to distinguish genuine entrepreneurial opportunities hence need more debts as compared to founder firms (Randøy & Goel, 2003). Although some prior studies show that male CEOs prefer debt, it is demonstrated that male CEOs will take less risk, after controlling for the impact of other relevant variables. Also of interest to this study are CEOT and DUA. The results show positive coefficients on CEOT and DUA. However, only that of CEOT reaches the conventional significance level. The results indicate that a long-serving CEO may become less conservative and inclined to borrow more. This could be because a CEO having served a company

for a long period has gained experience and thus is more tactful in taking risks.

To highlight and evaluate the impact of CEO ownership on the association between leadership's attributes and leverage, an interaction variable between the five leadership's attributes and CEO ownership was included. Based on the results of Equation (2) in Table 4, the interaction terms are all positive, with the interaction terms on CEOF*CEOOW, CEOT*CEOOW, and GEN*CEOOW reaching the conventional significance level. These results noticeably illustrate the advantages of CEO ownership in a company. In other words, the higher the

CEO ownership in a company, the more likely the CEO is to take risk. For brevity purpose, the results on the control variables are not discussed.

Robustness Test

To ensure the robustness of the results, our dependent variable was replaced with another proxy, viz. debt to capital ratio. The tenor of the results is not changed for both Equations (1) and (2). This indicates that human governance indeed has influence on corporate leverage decision. Moreover, these results are robust to estimation across subsamples. That is, the sample was

TABLE 4
OLS regression (N = 1,110 firm-year observations)

Variable	Equation (1)		Equation (2)	
	Coefficient	p-value	Coefficient	p-value
Constant	0.579**	0.010	0.652***	0.005
CEOA	-0.005***	0.000	-0.004***	0.000
CEOF	-0.053***	0.006	-0.068**	0.010
CEOT	0.002**	0.015	0.003***	0.000
DUA	0.017	0.542	0.023	0.473
GEN	-0.193***	0.005	-0.199***	0.006
ROA	-1.116***	0.000	-1.084***	0.000
SIZE	0.039***	0.001	0.034***	0.007
BIND	-0.013	0.884	0.000	0.999
BSIZE	-0.016***	0.005	-0.020***	0.001
Interaction terms:				
CEOOW			-0.011	0.180
CEOA*CEOOW			0.000	0.250
CEOF*CEOOW			0.003*	0.052
CEOT*CEOOW			0.000***	0.000
DUA*CEOOW			0.000	0.786
GEN*CEOOW			0.016**	0.013
Adjusted R ²	0.150		0.161	
F-statistic	22.683***		15.104***	

Note: *, **, and *** denote the statistical significance at the 10%, 5%, and 1% level, respectively.

partitioned and separate regression tests were run on the two groups (companies with CEO ownership vs. companies without CEO ownership).

Finally, OLS may not adjust for firm-specific or year-specific effects, which would cause an omitted variables bias problem. The fixed-effect model and random-effect model can solve this problem through the firm-specific or/and time-specific intercepts. A Hausman test was conducted to decide whether to employ a fixed-effect model or a random-effect model. The Hausman test statistics (P-value < 0.05) suggest the use of a fixed-effect specification. The results shown in Table 4 continue to hold when fixed-effects panel data regression analysis, which in a way supports our use of OLS as the main procedure was run. It is to be noted that the data set of this study is a panel data set.

CONCLUSION

This study examines the relationship between a CEO personal characteristics and a firm's leverage decision for the period from 2002 to 2011. The moderating effect of CEO ownership on the association between CEO personal characteristics and leverage was also evaluated. The findings can be summarized as follows. (1) CEO age is significantly and negatively related to leverage; (2) a founder-CEO is significantly and negatively related to leverage; (3) CEO tenure is significantly and positively related to leverage; (4) CEO duality is positively related to leverage, but it is not significant; (5) CEO gender

is significantly and negatively related to leverage; and (6) CEOs owning shares in a company will more likely to take risk. While having leverage means higher risk, it is suggested that companies may increase their CEO shareholdings so that CEO will align their personal interest with the ultimate company's goal.

While there may have been other incentives that have not been examined, it is shown that the most obvious (at least to us) is possible CEO personal characteristics in determining leverage decision. While this study is based on a relatively small sample, and hence has to be viewed as suggestive only. One obvious future empirical extension to this study is to explore the effect of CEO experience, CEO perspective, and CEO race on cost of debt. It was also particularly time-consuming to hand collect the CEO information from the annual reports of our sample companies.

REFERENCES

- Abor, J. (2007). Corporate governance and financing decisions of Ghanaian listed firms. *The International Journal of effective Board Performance*, 7(1), 83-92.
- Almeida, H., Ferreira, D., & Adams, R. B. (2005). Powerful CEOs and their impact on corporate performance. *Review of Financial Studies*, 18, 1403-1432.
- Berger, J. S., Ofek, E., & Yermack, D. (1997a). Managerial entrenchment and capital structure decisions. *Journal of Finance*, 52, 1411-1438.
- Berger, J. S., Ofek, E., & Yermack, D. (1997b). Managerial entrenchment and capital structure decisions *Journal of Finance*, 52, 1411-1438.

- Bertrand, M., & Schoar, A. (2003). Managing with style: The effect of managers on firm policies. *The Quarterly Journal of Economics*, *CXVIII*(4), 1169-1208.
- Coleman, S., & Cohn, R. (2000). Small firm use of financial leverage: Evidence from 1993 national survey of small business finance. *Journal of Business Entrepreneurship*, *12*(3), 81-98.
- Cronqvist, H., Makhija, A. K., & Yonker, S. E. (2012). Behavioral consistency in corporate finance: CEO personal and corporate leverage. *Journal of Financial Economics*, *103*(1), 20-40.
- Daily, C. M., Dalton, D., & Cannella, A. (2003). Corporate governance: Decades of dialogue and data. *Academy of Management Review*, *28*(3), 371-382.
- Faccio, M., Marchica, M. T., & Mura, R. (2012). CEO gender, corporate risk-taking, and the efficiency of capital allocation. Available at SSRN: <http://dx.doi.org/10.2139/ssrn.2021136>.
- Fischer, H., and Pollock, T. (2004). Effects of Social Capital and Power on Surviving Transformational Change: The Case of Initial Public Offerings. *Academy of Management Journal*, *47*(4), 463-481.
- Fosberg, R. H. (2004). Agency problems and debt financing: leadership structure effects. *Corporate Governance*, *4*(1), 31-38.
- Fraser, D. R., Zhang, H., & Derashid, C. (2006). Capital structure and political patronage: The case of Malaysia. *Journal of Banking & Finance*, *30*(4), 1291-1308.
- Friend, I., & Hasbrouck, M. (1988). Determinants of capital structure. *Research in Finance*, *7*(1), 1-19.
- Gomez, E. T. (2002). Political business in Malaysia: party factionalism, corporate development, and economic crisis. *Political business in East Asia*. London: Routledge, 82-114.
- Hasan, Z. (2009). Corporate Governance : Western and Islamic Perspectives. *International Review of Business Research Papers*, *5*(1), 277-293.
- Heminway, J. M. (2007). Sex trust and corporate boards. *Hastings Women's Law Journal*, *18*, 173-193.
- Jensen, M. C., & Meckling, W. H. (1976). Theory of the firm: Managerial behavior, agency costs and ownership structure. *Journal of Business Venturing*, *52*(4), 305-360.
- Johnson, S., & Mitton, T. (2003). Cronyism and capital controls: evidence from Malaysia. *Journal of Financial Economics*, *67*(2), 351-382.
- Kim, Y. H., Rhim, J. C., & Friesner, D. L. (2007). Interrelationships among capital structure, dividends, and ownership: evidence from South Korea. *Multinational Business Review*, *15*(3), 25-42.
- Modigliani, F., & Miller, M. H. (1958). The cost of capital, corporation finance and the theory of investment. *The American Economic Review*, *48*(3), 261-297.
- Morck, R., Shleifer, A., & Vishny, R. W. (1988). Management ownership and market valuation: An empirical analysis. *Journal of Financial Economics*, *20*, 293-315.
- Murphy, K. J. (1999). *Executive Compensation*, in Ashenfelter, O., Card, D. (Ed.): Handbook of Labor Economics Elsevier Science North Holland.
- Mustapha, M., & Ismail, H. B. (2011). *Determinants of debt structure: Empirical evidence from Malaysia*. 2nd International conference on Business and Economic Research (2nd ICBER 2011) proceeding.
- Pandey, I. (2004). Capital structure, profitability and market structure: Evidence from Malaysia. *Asia Pacific Journal of Economics and Business*, *8*(2), 78.

- Randøy, T., & Goel, S. (2003). Ownership structure, founder leadership, and performance in Norwegian SMEs: implications for financing entrepreneurial opportunities. *Journal of Business Venturing*, 18(5), 619-637.
- Richard, O., & Shelor, R. (2002). Linking Top Management Team Age Heterogeneity to Firm Performance: Justaposing Two Mid-Range Theories. *International Journal of Human Resource Management*, 13(6), 958-974.
- Salleh, A., Ahmad, A., & Kumar, N. (2009). Human Governance: A neglected mantra for continuous performance improvement. *Performance Management*, 48(9), 26-30.
- Suhaila, M. K., & Wan Mahmood, W. M. (2008). *Capital structure and firm characteristics: Some evidence from Malaysian companies*. Retrieved from: <http://mpa.ub.uni-muenchen.de/14616>.
- Suto, M. (2003). Capital structure and investment behaviour of Malaysian firms in the 1990s: a study of corporate governance before the crisis. *Corporate Governance: An International Review*, 11(1), 25-39.
- Ting, I. W. K., & Lean, H. H. (2011). Capital structure of government linked companies in Malaysia. *Asian Academy of Management Journal of Accounting and Finance*, 7(2), 137-156.
- Vroom, V. H., & Pahl, B. (1971). Relationship between Age and Risk Taking among Managers. *Journal of Applied Psychology*, 55(5), 399-405.
- White, H. (1980). A heteroskedasticity-consistent covariance matrix estimator and a direct test for heteroskedasticity *Econometrica*, 48(4), 817-838.
- Yau, J., Lau, E., & Liwa, A. (2008). *Do Malaysian firms practice the pecking order theory in their capital structure*. Proceedings of the MFA conference.
- Zwiebel, J. (1996). Dynamic capital structure under managerial entrenchment. *The American Economic Review*, 86, 1197-1215.

***Terras* (*Eusideroxylon zwageri* Teijsm. & Binn.), a Cultural Keystone Species of the Berawan People of Sarawak, Malaysia**

Franco, F. M.^{1*}, Ghani, B. A. A.² and Hidayati, S.¹

¹*Curtin Sarawak Research Institute, Curtin University Sarawak Malaysia*

²*School of Continuing Studies, Curtin University Sarawak Malaysia*

ABSTRACT

This article showcases the unique position accorded to the *terras* tree (*Eusideroxylon zwageri* Teijsm. & Binn. Lauraceae) in the Berawan culture. We collaborated with the Berawan people of the Loagan Bunut region of Sarawak, to uncover the most important tree in their culture. In a group interview, the participants ranked the *terras* as the most important tree. The Identified Cultural Influence of Cultural Keystone Species (ICI) and the Use Value Index (UV) was found to be extraordinarily high at 35 and 6.05 respectively. The multidimensional use value of the tree, stemming from its hardy timber, could be the reason behind its cultural importance. We conclude that the *terras* tree should be protected even outside the national parks for its ecological and cultural value.

Keywords: Traditional knowledge, culture, native, vulnerable species, community, belian, biocultural diversity, ecological restoration

INTRODUCTION

Cultural Keystone Species (CKS) are species that enjoy a unique position in the culture of a community (Cristancho & Vining, 2004; Garibaldi & Turner, 2004). Keystone species plays a pivotal role in the natural

ecosystem, while cultural keystone species play an important role in maintaining the culture of a community (Paine, 1969). Just as the removal of the former might result in irreparable loss to the ecosystem, the loss of the latter might lead to loss of a culture or its components. This understanding is one of the reasons for the emerging of the field of Biocultural Diversity that explores the links between linguistic, cultural, and biological diversity (Loh & Harmon, 2005; Maffi, 2005). New studies agree that culture and ecology are inseparable entities and

ARTICLE INFO

Article history:

Received: 30 May 2013

Accepted: 3 March 2014

E-mail addresses:

mfranco@curtin.edu.my (Franco, F. M.),

bibi.aminah@curtin.edu.my (Ghani, B. A. A.),

syafitrihidayati@gmail.com (Hidayati, S.)

* Corresponding author

culturally important species also happen to be ecologically significant ones (Close *et al.*, 2002; Maldonado *et al.*, 2013). Though critics of CKS argue that the term 'cultural keystone species' misuses the metaphor 'keystone species' (Davic, 2004), studies from different regions of the world have proven its credibility (Brosi *et al.*, 2007; Garibaldi, 2009; Butler *et al.*, 2012; Upreti *et al.*, 2013). The dual risk of loss of biodiversity and culture threatens the very existence of indigenous communities all over the world (UNESCO & UNEP, 2003); there is an urgent need for studies that could facilitate the conservation of both biodiversity and culture without negating opportunities for upward economic mobility (Gupta *et al.*, 2003). In this scenario, our study aims to uncover the most important tree in the culture of the Berawan people of Loagan Bunut and to promote an understanding of the traditional knowledge and cultural importance accorded to it.

The Berawan People

The Berawan people of Sarawak, who speak the Berawan language, are a native community traditionally involved in fishing. They are the only community accorded with native fishing rights in the natural lake of the Loagan Bunut National Park (LBNP). There are four main Berawan settlements viz., Long Teru in the lower Tinjar, Long Jegan in middle Tinjar, Batu Belah and Long Terawan in the lower Tutoh and middle Tutoh (Metcalf, 1976). Linguistically, the Berawan in Long Teru and Batu Belah share closer ties compared to the communities in

Long Jegan and Long Terawan (Metcalf, 1976). Hudson (1978) placed the Berawan language under the Rejang-Baram group while Blust (1972) placed it among the lower Baram languages.

Loagan Bunut- A Unique Ecosystem

The Loagan Bunut ecosystem is a unique one with a freshwater lake spanning around 650 ha playing a decisive role in the ecology of the protected forest. The lake is full most of the year, but can dry out occasionally when the water level in the Sungai Teru that feeds the lake goes down (Hon *et al.*, 2007; Sayok *et al.*, 2008). The plants and animals in the Loagan Bunut have co-evolved with this unique 'vanishing lake' and so has the Berawan culture. Their unique *selembau* system of fishing, where a scoop net on a floating platform is used to trap fishes (Jensen & Das, 2006), affirms the Berawan traditional knowledge and skills. This study is rooted in the idea that Berawan traditional knowledge and culture recognise the trees in their ecosystem with varying degrees of importance.

METHOD

The study was carried out in March 2013 in collaboration with the Berawan people of Loagan Bunut. We met the headmen of the two longhouses in the vicinity of Loagan Bunut national park viz. Rumah Kajan Sigeh and Rumah Meran Surang and obtained the mandatory Prior Informed Consent to proceed with the study. Open-ended questionnaires were used to elicit information on culturally important trees

from the participating volunteers. Interviews were a combination of focus group and individual focussed ones. At first, we invited knowledgeable volunteers to join us for a focus group interview to which around 16 people from Rumah Kajan Sigeh responded. We requested them to list the most important tree species in the Berawan culture. Following this, individual interviews were carried out with 20 volunteers (12 males and eight females) to assess the Identified Cultural Influence of cultural keystone species (ICI) for the top-ranking species of the list, as per the framework provided by Garibaldi and Turner (2004). Individual PICs were also obtained prior to these interviews. Volunteers were also requested to list down the uses of the tree in order to calculate the use value index as:

$$\text{Use value, UV} = \sum U_i/n,$$

where, 'U_i' is the number of uses mentioned by each informant for a given species and 'n' is the total number of informants (Rossato *et al.*, 1999).

The entire study conforms to the ISE code of ethics (International Society of Ethnobiology, 2006). It was also approved by the Human Research Ethics Committee of Curtin University, Sarawak.

Significance of ICI and Use Value Indices

Landscape changes are often accompanied by loss of species at least at the local level. While there are various ecological techniques to quantify the magnitude of loss, very few methods have been formulated to gauge its impact on human culture. The CKS

concept aims to fill the gap by demonstrating parallels between ecologically important species and culturally important species. Cristancho and Vining first proposed the concept of cultural keystone species; they used the term 'Culturally-defined Keystone Species' to designate "those plant and animal species whose existence and symbolic value are essential to the stability of a culture over time" (Cristancho & Vining, 2004); Garibaldi and Turner (2004) later introduced the framework for determining cultural keystone species. Since culture is a complex and dynamic entity, no single parameter can be used to assess the role of biological elements in it. ICI seeks to address this issue by considering multiple criteria such as the usage of the species, its position in the respective language, ceremonial roles, traditional knowledge, uniqueness and economy. The researchers elicited information on the above factors by asking a series of questions and then assigning scores in the range of 0-5 for each factor, with 5 indicating a high level of cultural significance for that criterion. Thus, the highest possible score for a species is 35 (5 x 7). The CKS model goes beyond understanding the importance of a species in the culture. Garibaldi (2009) has successfully used this model to select seven CKS of the Dene, Cree and Métis people of Fort McKay in Alberta, Canada, to reclaim a large scale bitumen extraction area. Recently, Upreti *et al.* (2013) has also applied the ICI framework to understand the cultural importance of white pine (*Pinus strobus* L.) for the Kitcisakik Algonquin

community of western Quebec, Canada. Recognising the importance of CKS in ecological restoration processes, Eitzel *et al.* (2012) picked up the article by Garibaldi and Turner (2004) as one among the 10 most important articles on ecological restoration. Unlike most ecological indices, ICI depends on the ability of the researcher to assign the appropriate ratings to each parameter. Though this might appear as a limitation, trained ethnobiologists or anthropologists who have gained an insider's perspective of the particular culture are less likely to make judgemental errors. Moreover, the usage of an additional index such as the use value index will facilitate the juxtaposition of results against each other so as to get a clearer picture.

Use value index is classified as a Relative Cultural Index (RCI) that measures the importance of taxa to a particular community (Hoffman & Gallaher, 2007). Prance *et al.* in 1987 calculated the use values of trees to four indigenous people of the Amazonian region. They assigned a value of 1.0 to 'major' uses and 0.5 to 'minor' uses. The familial use value was then calculated by summing the use values of individual species in a family and then dividing it by the number of all species in that family, occurring in the study plot. Later, Phillips and Gentry (1993a; 1993b) calculated the use value of a species for an informant by adding the total number of uses cited for the species and dividing it by the number of 'events'. The use value for one species was then calculated as the sum of the informant use values for that species divided

by the total number of informants. This was later adapted by Rossato *et al.* (1999) as the sum of the use categories divided by the number of informants (also see Albuquerque *et al.*, 2006). Unlike the ICI, the use value index is based on "informant consensus" and hence is more objective (Tardio & Pardo-de-Santayana, 2008). However, the use value index does not distinguish between active and passive uses unless the researcher specifically distinguishes these two forms of knowledge during the interviewing process.

One intentional deviation in the application of use value index in this research is that the number of uses cited for the tree are individual uses and not use categories. For instance, usability in making of cross and mirror frames are considered as two separate uses. This is in contrast to the opinion of Hoffman and Gallaher (2007) that the consideration of individual uses might lead to an exaggerated score. Our rationale is that each use has a cultural value behind it and no two uses have the same extent of cultural value to be counted as one use category. For instance, though the cross and mirror frames are both wooden structures, the cross has a higher cultural value to a Christian community. Likewise, an ornate mirror frame is not in the same league as the staircase as it has higher cultural significance.

RESULTS

Our study shows that the *terras* tree (*Eusideroxylon zwageri* Teijsm. & Binn. Lauraceae) is the most important tree in the culture of the Berawan of Loagan Bunut. It

is native to Malesia and popularly known as *belian* in Bahasa Melayu and as Bornean Ironwood in English; *terras* is the Berawan name given to the tree. The ratings received by *terras* for each criterion of ICI are provided in Table 1.

Our interviews show that despite its increasing rarity, the *terras* tree is still used routinely for multiple purposes including cultural artefacts. The Berawan of Loagan Bunut are nostalgic about the past when there used to be an abundance of *terras* trees in their neighbourhood, and they strongly believe that the tree cannot be replaced by any other species. The high timber value of the tree still gets them enough revenue through trade, though not at the same magnitude as before. The use value index for *terras* from our interviews with 20 volunteers was found to be 6.05.

$$\begin{aligned} \text{Use value, UV} &= (6+4+4+7+6+3 \\ &+3+6+9+12+3 \\ &+10+7+7+4+4 \\ &+8+7+6+5)/20 \\ &= 6.05 \end{aligned}$$

From the individual interviews carried out to elicit the use value, we understood that the *terras* tree is a multipurpose tree with a diverse range of uses, mostly attributed to its hardwood properties. Due to its all-weather usability, the *terras* tree is used to make wooden structures that risk exposure to sun, rain, wear and tear. The wood is used to make coffins, crosses, wooden sculptures, pillars for longhouses, gates, outdoor staircases, ornate frames for mirrors, pestles, handles for implements and wooden floorings. *Terras* stalks can be used as supports for black pepper and also

TABLE 1
Identified Cultural Influence of *terras* (after Garibaldi & Turner, 2004)

Elements that indicate a cultural keystone	Ratings
Intensity, type and multiplicity of use	5
Is this species used intensively (routinely and in large quantities?)	
Does this species have multiple uses?	5
Naming and terminology in language, including uses as seasonal or phenological indicators, names of months or seasons, place names	5
-Does the language incorporate names and specialised vocabulary relating to the species	
Role in narratives, ceremonies or symbolism	5
-Is it prominently featured in narratives and or ceremonies, dances, songs or as a major crest, totem or symbol?	
Persistence and memory of use in relation to cultural change	5
-Is the species ubiquitous in the collective cultural consciousness and frequently discussed?	
Level of unique position in culture	5
-Is it difficult to replace with other available native species?	
Extent to which it provides opportunities for resource acquisition from beyond the territory	5
-Is it used as a trade item for other groups?	
Total	35

Responses to questions were rated in the scale of 5-0 as: 5 (yes, very high), 4 (yes, high), 3 (yes, moderate), 2 (yes, low) 1 (yes, though very low or infrequent), 0 (no, not used).

to pierce holes in the ground for the planting of paddy. It can also be used to make spoons and *keeshang*, a manual paddy dehusker.

During secondary burials accorded to members of elite clans of the Berawan in ancient days, the remains of the deceased would be left on a platform on the top of two poles called *lejeng* (Fig.1), which are essentially two *terras* tree trunks. These trunks are known for their elaborate carvings; two may still be seen in the Loagan Bunut National Park. It is taboo to touch or disturb these poles even if they happen to fall on their own. Violators will either have to offer a pig as sacrifice or provide material donations to the family of the deceased as compensation.

Terras is too heavy to float on water, making it difficult to transport in a swampy ecosystem such as the Loagan Bunut; the Berawan people used to tie them to buoyant trees and then float them downstream.

However, the same heavy tree after drying and thinning can be used to make bilges of boats. Boats have a unique place in Berawan culture as they were the sole mode of transportation in the swampy Loagan Bunut terrain until the advent of logging roads and 4-wheel drive vehicles. They are still used for fishing and collection of wild produce.

Besides recalling the uses of the tree, the volunteers also shared information on the ecological importance of the *terras*. Owing to its tall nature, hornbills and eagles nest in the canopy of the tree. Giant squirrels, known as *kerawak* in Berawan (*Ratufa affinis* Raffles, 1821) can be seen aplenty at the base of the tree. The flower buds are relished by the *nyikek* (Muller's Bornean Gibbon, *Hylobates muelleri* Martin 1841). Two species of porcupine (identity unconfirmed) also feed on the fruit of the *terras*. Both of these porcupine species were once hunted by the people.



Fig.1: The *lejeng* poles of Loagan Bunut National Park

In general, the participants were of the view that the rarity of the species caused by logging and expansion of palm oil plantations outside the National Park territory has had an impact on its usability as well as on the skills and traditional knowledge of the people related to the tree. The consensus among the participants on the result of the above phenomenon is that the younger generation has lost most of the traditional knowledge of *terras*, though they consider this species as an 'important and irreplaceable' one.

DISCUSSION AND CONCLUSION

The *terras* tree ranks high (35/35) in terms of ICI, indicating the high importance accorded to it in the Berawan culture. It excels in all the six criteria required for a species to be considered as a cultural keystone species. The high use value of six is an indication that on average, people know at least six uses of the plant. However, it should be borne in mind that this study considers independent uses and not use categories. The Berawan language recognises this tree by the name *terras*, which is unrelated to the Bahasa Melayu name, *belian*. It is an essential feature of indigenous languages to recognise important elements in an ecosystem by indigenous names (Johannes, 1993; Franco & Narasimhan, 2009; Si, 2013). Artefacts made of *terras* too find a prominent place in the Berawan culture. The top ranking accorded to *terras* is justified as the ICI and use value clearly agree with the consensus that emerged in the group interview that the *terras* is the most important tree in Berawan

culture. The fact that Berawan use *terras* as *lejeng* poles to honour the deceased souls and the taboos and the sanctity associated with the structure further corroborate this consensus. There is considerable amount of debate on the right to secondary burials with some authors of the view that secondary burials were the privilege of an elite class while some others argue that it was just a matter of economic capability (Metcalf, 1981). However, our informants agreed with the former. A deceased soul is elevated to the role of 'ancestor' and venerated by the native community, which is the general practice the world over; it is only natural that a tree associated with such beliefs immediately gains prominence in the culture (Fortes, 1965; Soles, 2001). For the Berawan of Loagan Bunut who adopted Christianity, the wooden cross is the most important cultural symbol. Being the most preferred tree for making the cross also imparts an aura of regality to the tree. From the uses and the results of the indices, we understand that the multidimensional properties of the tree, stemming from its hardy timber, is the chief reason behind the top rank accorded to it. It should be noted here that of all the timber species in Sarawak, *terras* offers the highest degree of resistance to marine borers (Choon & Cookson, 1996). Plants and animals can be used to convey a message of political power and status; it can be argued that the *terras* is equated with aristocracy just as the lion is equated with power and strength all over the world.

The tree, besides ranking high in the ICI, is also unique and irreplaceable for

the community. Studies from other parts of Borneo show that *E. zwageri* enjoys a similar position in other native cultures too. For instance, the Dayak Benuaq Ohookng people of East Kalimantan use the tree to conjure spirits as it incorporates mystic power (Zahorka, 2007); the tree is also used for medicinal purposes in Kalimantan (Wahyuni, 2011). Research done in Malinau, Indonesia also show that *E. zwageri* is the most preferred tree in the local culture for construction purposes (Sheil *et al.*, 2007; Moeliono *et al.*, 2009). Owing to its importance in native cultures, communities have devised various traditional management systems to manage the population of *terras*, and Peluso (1992) argues that the traditional management regimes of the native communities can foster better conservation of *E. zwageri*. There is also enough evidence to show that *E. zwageri* has to be conserved for its ecological importance (Eltz *et al.*, 2003; Sheil & van Heist, 2000; Whitmore, 1984).

The Berawan people's claim that commercial logging and plantations have contributed to the rarity of the *terras* tree outside the national park is supported by researchers who have studied the change in land use of Loagan Bunut (Sayok *et al.*, 2009). The example of low visibility of hornbills in Borneo and elsewhere caution that cultural importance given to a species can also lead to a decline in its population (Bennett *et al.*, 1997; Choudhury, 2009). However, in the case of *terras*, decline in population is mainly attributed to the commercial or illegal logging and not its

cultural use (Bullinger, 2006; Peluso, 1992).

The cultural importance accorded to any species depends on its usability and availability to the community. In other words, it is essential that the species be present both in the physical and collective memory domains (Nabhan, 2000). For instance, a study by Ramstad *et al.* (2007) shows that the survival of Maori traditional knowledge on *tuatara* (*Sphenodon* spp.) and the latter's position in Maori culture is intrinsically linked to the availability of *tuatara*. Another study by Mathew *et al.* (2006) on *Artocarpus hirsutus* Lam., an endemic tree from the Western Ghats of India, shows that changing cultural preferences related to a species may lead to a decline in the availability of that species.

Recognising its rapidly declining population, IUCN has classified *E. zwageri* as a 'vulnerable species' as per the criteria A1cd+2cd (IUCN 2012). Clearly, over exploitation, shifting agriculture, timber export, coupled with the slow radial growth rate of 0.058 cm y⁻¹ (Kurokawa *et al.*, 2003), appears to have contributed to its vulnerable status. As indicated by Garibaldi and Turner (2004), the ecological status of a CKS can limit its availability for cultural purposes. We feel that if a situation arises in future where there are no *terras* available to the Berawan and other interacting cultures, there is a risk of the tree's losing its cultural importance, leading to both loss of species as well as erosion of culture at the local level. At present, it is encouraging to see the contemporary Berawan culture recognising the importance of the species.

ACKNOWLEDGEMENTS

We thank the Curtin Sarawak Research Institute (CSRI) for the financial support received for this project. We thank Prof. Aaron Goh, Director, CSRI and Ms. Florence Singa, CSRI for their kind support. The enthusiasm and support of the officials of the Loagan Bunut National Park played a crucial role in carrying out the project. We also thank the State Planning Unit, Sarawak and the Forest Department, Sarawak, for permitting us to undertake this study. This article benefitted immensely from the valuable comments given by the three anonymous reviewers; we thank them for their kind inputs. Biocultural Diversity survives on earth only because of the dedication of its custodians who put it into practice; we thank the Berawan people of Rumah Kajan Sigeh and Rumah Meran Surang, Loagan Bunut, especially Mr. Jalin Luta, for sharing their invaluable knowledge with us.

REFERENCES

- Albuquerque, U. P., Lucena, R. F. P., Monteiro, J. M., Florentino, A. T. N., & Almeida, C. (2006). Evaluating two quantitative ethnobotanical techniques. *Ethnobotany Research and Applications*, 4, 51–60.
- Bennett, E. L., Nyaoi, A. J., & Sompud, J. (1997). Hornbills *Buceros* spp. and culture in northern Borneo: Can they continue to coexist? *Biological Conservation*, 82, 41–46.
- Blust, R. A. (1972). Report of linguistic field work undertaken in Sarawak. *Borneo Research Bulletin*, 4, 12–13.
- Brosi, B.J., Balick, M.J., Wolkow, R., Lee, R., Kostka, M., *et al.* (2007). Cultural erosion and biodiversity: Canoe-making knowledge in Pohnpei, Micronesia. *Conservation Biology*, 21, 875–879.
- Bullinger, C. (2006). *Comparison of local government's policies on Kutai and Dayak Benuaq villages in Kutai Barat, Indonesia: Factors influencing village life and household well-being since decentralization*. Bogor, Indonesia: Center for International Forestry Research (CIFOR).
- Butler, J. R. A., Tawake, L., Tawake, A., Skewes, T. & McGrath, V. (2012). Integration of traditional ecological knowledge and fisheries management in the Torres Strait, Australia: The catalytic role of turtles and dugong as cultural keystone species. *Ecology and Society*, 17(4), 34.
- Cristancho, S., & Vining, J. (2004). Culturally defined keystone species. *Human Ecology Review*, 11(2), 153–164.
- Choon, L. W., & Cookson, L. J. (1996). *Laboratory study on the natural durability of Sarawak timbers against marine borers*. Kuching: Timber Research and Technical Training Centre, Forest Department.
- Choudhury, A. (2009). Significant recent ornithological records from Manipur, North-east India, with an annotated checklist. *Forktail*, 25, 71–89.
- Close D. A., Fitzpatrick, M. S., & Li, H. W. (2002). The ecological and cultural importance of a species at risk of extinction, Pacific lamprey. *Fisheries*, 27, 19–25.
- Davic, R. D. (2004). Epistemology, culture and keystone species. *Ecology and Society*, 9(3).
- Eitzel, M. V., Diver, S., Sardifias, H., Hallett, L.M., Olson, J. J., *et al.* (2012). Insights from a cross-disciplinary seminar: 10 Pivotal Papers for Ecological Restoration. *Restoration Ecology*, 20(2), 147–152.
- Eltz, T., Bruhl, C. A., Imiyabir, Z., & Linsenmair, K. E. (2003). Nesting and nest trees of stingless bees (Apidae: Meliponini) in lowland dipterocarp

- forests of Sabah, Malaysia, with implications for forest management. *Forest Ecology and Management*, 172, 301–313.
- Franco, F. M., & Narasimhan, D. (2009). Plant names and uses as indicators of knowledge patterns. *Indian Journal of Traditional Knowledge*, 8(4), 645-648.
- Fortes, M. (1965). Some reflections on ancestor worship in Africa. In M. Fortes, & G. Dieterlen (Eds.). *African Systems of Thought* (pp. 122-142). London: Oxford University Press.
- Garibaldi, A., & Turner, N. (2004). Cultural keystone species: Implications for ecological conservation and restoration. *Ecology and Society*, 9(3), 1.
- Garibaldi, A. (2009). Moving from model to application: Cultural keystone species and reclamation in Fort McKay, Alberta. *Journal of Ethnobiology*, 29(2), 323-338.
- Gupta, A. K., Sinha, R., Koradia, D., Patel, R., Parmer, M., et al. (2003). Mobilizing grassroots technological innovations and traditional knowledge, values and institutions: Articulating social and ethical capital. *Futures*, 35, 975-987.
- Hoffman, B., & Gallaher, T. (2007). Importance indices in ethnobotany. *Ethnobotany Research and Applications*, 5, 201–218.
- Hon, J., Sylvia, N. G., Kong, D., & Gumal, M. (2007). Loagan Bunut National Park – A refuge for lowland birds? In *Proceedings of the ninth Hornbill workshop on protected areas and biodiversity conservation* (p. 228-235). Kuching: Sarawak Forestry.
- Hudson, A.B. (1978). Linguistic relations among Bornean peoples with special reference to Sarawak: An interim report. *Studies of Third World Societies*, 3, 1-44.
- International Society of Ethnobiology (2006). *International Society of Ethnobiology Code of Ethics (with 2008 additions)*. Retrieved April 05, 2013, from <http://ethnobiology.net/code-of-ethics/>
- IUCN (2012). *IUCN red list of threatened species. Version 2012.2*. Retrieved July 16, 2013, from www.iucnredlist.org
- Jensen, K., & Das, I. (2006). *Biological observations on the Asian soft-shell turtle in Sarawak, Malaysian Borneo, with notes on the biology and conservation of other non-marine turtles. For the Care and Conservation of Tortoises, Terrapins and Turtles Worldwide*. Retrieved 06 April, 2013, from http://asianturtlenetwork.org/library/reports_papers/papers/Testudo_article_on_Amyda_by_KJensen_2006.pdf
- Johannes, R. E. (1993). Integrating traditional ecological knowledge and management with environmental impact assessment. In J. T. Inglis, (Ed.). *Traditional ecological knowledge: Concepts and cases* (pp. 33-40). Ottawa: International Program on Traditional Ecological Knowledge and International Development Research Centre.
- Kurokawa, H., Yoshida, T., Nakamura, T., Lai, J., & Nakashizuka, T. (2003). The age of tropical rain-forest canopy species, Borneo ironwood (*Eusideroxylon zwageri*), determined by 14C dating. *Journal of Tropical Ecology*, 19(01), 1-7.
- Loh, J., & Harmon, D. (2005). A global index of biocultural diversity. *Ecological Indicators*, 5, 231–241.
- Maffi, L. (2005). Linguistic, cultural, and biological diversity. *The Annual review of Anthropology*, 29, 599–617.
- Maldonado, B., Caballero, J., Delgado-Salinas, A., & Lira, R. (2013). Relationship between use value and ecological importance of floristic resources of seasonally dry tropical forest in the balsas river basin, México. *Economic Botany*, 67, 17-29
- Moeliono, M., Wollenberg, E., & Limberg, G. (2009). *The decentralization of forest governance*. London: Earthscan.
- Mathew, S. P., Mohandas, A., Shareef, S. M., & Nair, G. M. (2006). Biocultural diversity of the

- endemic 'wild jack tree' on the Malabar coast of South India. *Ethnobotany Research and Applications*, 4, 025-040.
- Metcalf, P. (1976). Who are the Berawan? Ethnic classification and distribution of secondary treatment of the dead in central north Borneo. *Oceania*, 40(7), 85-105.
- Metcalf, P. (1981). Meaning and materialism: The ritual economy of death. *Man*, 16(4), 563-578.
- Nabhan, G. P. (2000). Interspecific relationships affecting endangered species recognized by O'odham and Comc'aac cultures. *Ecological Applications*, 10, 1288-1295.
- Paine, R. T. (1969). A note on trophic complexity and community stability. *The American Naturalist*, 103(929), 91-93.
- Peluso, N. L. (1992). The ironwood problem: (Mis) Management and development of an extractive rainforest product. *Conservation Biology*, 6(2), 210-219.
- Phillips, O., & Gentry, A. H. (1993a). The useful plants of Tambopata, Peru: I. Statistical hypothesis tests with a new quantitative technique. *Economic Botany*, 47, 15-32.
- Phillips, O., & Gentry, A. H. (1993b). The useful plants of Tambopata, Peru: II. Additional hypothesis testing in quantitative ethnobotany. *Economic Botany*, 47, 33-43.
- Prance, G. T., Balée W. B., Boom, M., & Carneiro, R. L. (1987). Quantitative ethnobotany and the case for conservation in Amazonia. *Conservation Biology*, 1, 296-310
- Ramstad, K. M., Nelson, N. J., Paine, G., Beech, D., Paul, A., Paul, P., Allendorf, F. W., & Daugherty, C. H. (2007). Species and cultural conservation in New Zealand: Maori traditional ecological knowledge of tuatara. *Conservation Biology*, 21, 455-464.
- Rossato, S. C., Leitão-Filho, H. F., & Begossi, A. (1999). Ethnobotany of Caiçaras of the Atlantic forest coast (Brazil). *Economic Botany*, 53, 387-395.
- Sayok, A. K., Nik, A. R., Melling, L., Samad, R. A., & Efransjah, E. (2008). Some characteristics of peat in Loagan Bunut National Park, Sarawak, Malaysia. In J. O. Reiley, C. J. Banks, & B. Radjaguguk (Eds.). *Carbon-climate-human interactions on tropical peatland, Yogyakarta, 27-29 August 2007* (pp. 92-100). United EU CARBOPEAT and RASTORPEAT partnership, Gadjah Mada university, Indonesia and University of Leicester, United Kingdom.
- Sayok, A. K., Seng, L., & Belanda, R. D. (2009). Impacts of land-use on Bunut Lake, Sarawak, Malaysia. *13th World lakes Conference, Wuhan, China. 1-5 November, 2009*. Retrieved 10 July, 2013, from http://wldb.ilec.or.jp/data/ilec/WLC13_Papers/S15/s15-4.pdf
- Sheil, D., Padmanaba, M., van Heist, M., Basuki, I., Liswanti, N., Wan, M., Puri, R.K., Rukmiyati, Rachmatika, I., & Samsuudin, I. (2007). Examining the conservation significance of local peoples' perceptions and uses of different forested landscapes. In P. Gunarso, T. Setyawati, T. Sunderland, & C. Shackleton (Eds.). *Managing forest resources in a decentralized environment: lessons learnt from the Malinau research forest, east Kalimantan Indonesia* (pp. 27-45). Bogor, Indonesia: CIFOR.
- Sheil, D., & van Heist, M. (2000). Ecology for tropical forest management. *International Forestry Review*, 2, 261-270.
- Si, A. (2013). Aspects of honeybee natural history according to the Solega. *Ethnobiology letters* 4, 78-86.
- Soles, J. S. (2001). Reverence for dead ancestors in prehistoric crete. In R. Laffineur, & R. Hägg (Eds.). *Proceedings of the 8th International Aegean Conference/8e Rencontre égéenne internationale. Göteborg, Göteborg University, 12-15 April 2000* (p. 229-236). Liège: Université de Liège.

- Tardío, J., & Pardo-de-Santayana, M. (2008). Cultural importance indices: A comparative analysis based on the useful wild plants of southern Cantabria (Northern Spain). *Economic Botany*, 62, 24–39.
- UNESCO & UNEP (2003). *Cultural diversity and biodiversity for sustainable development*. Nairobi: UNEP. Retrieved 20 September, 2013, from <http://unesdoc.unesco.org/images/0013/001322/132262e.pdf>
- Upreti, Y., & Asselin, H. (2013). Cultural importance of white pine (*Pinus strobus* L.) to the KitcisakikAlgonquin community of western Quebec, Canada. *Canadian Journal of Forest Research*, 43, 544–551.
- Wahyuni, T. (2011). *Can traditional forest management protect and conserve ironwood ulin stands? An option and approach in East Kalimantan*. (PhD thesis). Leiden: University of Leiden.
- Whitmore, T. C. (1984). *Tropical rain forest of the Far East*. (2nd ed.). Oxford, UK: Clarendon Press.
- Zahorka, H. (2007). The Shamanic belian sentiu rituals of the Benuaq Ohookng, with special attention to the ritual use of plants. *Borneo Research Bulletin*, 38, 127-147.

Diasporic Dwellings: The Family House and its Role in the Creative Imaginary of Selected Malaysian Indian Writers

Shangeetha, R. K.^{1*} and Pillai, S.²

¹*Academy of Language Studies, Universiti Teknologi MARA, 40450 Shah Alam, Selangor, Malaysia*

²*Faculty of Social Sciences and Humanities, Universiti Kebangsaan Malaysia, 43600 Bangi, Selangor, Malaysia*

ABSTRACT

Coming from a community born primarily out of the indenture experience, the creative writings that have emerged from the communal compound of the Malaysian Indian diaspora almost inevitably touch on the poetics of loss of homeland and the struggle to reinvent identity in a new land. While there are the inescapable signifiers of trauma in the disillusionment of finding what was hoped to be a promised land, they are set to the rhythms of the new land. While the object of mourning may be unreachable, its semblances are seen in the new land and efforts are made to reinvent the object of loss, leading to a form of substitution. Allegiance to a land of memories becomes located more in its rituals and its religion and the attendant myths and metaphors, a spiritual homeland more than the imagined nation that could have been. Hence, historical remembrance is no more the core theme of Malaysian Indian diasporic experience as there are other various forms of representations of the Malaysian Indian diasporic consciousness. In the context of creative writings, it is also a fertile ground for the articulation of the creative imaginary. However, the terrain is multi-faceted and the following discussion will reveal a small section of the variations in the articulation and perception of the concept of the house, and its varying features as it dwells in the pages of three Malaysian Indian novelists, K. S. Maniam, Rani Manicka and Preeta Samarasan.

Keywords: Diasporic memory, K. S. Maniam, Malaysian Indian writings, Preeta Samarasan, Rani Manicka

ARTICLE INFO

Article history:

Received: 26 August 2013

Accepted: 8 March 2014

E-mail addresses:

geet76_my@yahoo.com (Shangeetha, R. K.),

spillai@ukm.my (Pillai, S.)

* Corresponding author

INTRODUCTION

Most creative works that emerge from diasporic communities often tap into the narratives of communal beginnings. The collective memory of the story of Indian

migration to Malaysia reaches back to its beginnings in the large-scale migration of mainly South Indians to British Malaya during the end of the 19th century. Manpower was needed to work in palm oil and rubber plantations to supplement local labour. Indentured labourers from India were brought in to satisfy the demand for workers in the plantations in Malaya. These Indian labourers, regarded as 'sojourners', would in all probability have come with the expectation of remaining in Malaya for a short period of time to accumulate enough money and return to their homeland in India or Sri Lanka. However the promise of monetary returns was quite often a distant and remote reality, for migration came with much liability. One had to repay the debt of his passage through a period of bonded labour. Furthermore, there was also the financial burden of living expenses, which often tightened the noose of debt around the labourer. The consequences of these often resulted in an extension of the indenture contract and with it the diminishing horizon of a return to the homeland. Apart from the labouring class of migrants who were mainly from the rural areas of South India, there was also a large scale migration of English-educated Indians who played the mediatory role between the labouring class and the comprador European class of planters. Here too one would find the differing circles of subalternity, with the middle-class Indians playing subaltern roles when they are within the circle of their superiors, the British planters and other colonialist officials, and assuming the role

of dominator when encountering the Indian labourers. Such differences of roles and stature would have thus led to heterogeneity in experience, a fact that is reflected in the writings that would follow from their progeny generations in the future. Class, gender, ethnic group and other differences led to different experiences, inherited and articulated with different nuances.

The Malaysian Indian community today is testimony of the heterogeneity of its historical beginnings. Though in majority most have ancestral roots in South India, delve deeper and one will see the divisions of regional alliances such as Tamils, Malayalees, Telugus, Sri Lankan Tamils, Punjabis, Gujaratis and Sindhis. Out of these heterogeneous Indian ethnic groups, the Tamils, natives of Tamil Nadu region of India, form the majority; followed by the Telugus, natives of Andhra Pradesh; and Malayalees, natives of the Malabar Coast area comprising present-day Kerala state (Sandhu, 1993; Arasaratnam, 1993). In 1931, the Tamils "formed nearly 87 percent of the South Indian and more than 82 percent of the total population of Malaya [...] Of the other South Indians, only the Telugus and Malayalis have been present in significant numbers" (Sandhu, 1993, p. 160-161). The majority of Tamils and Telugus were brought in through the indenture and *Kangany* system to work as labourers in the rubber plantations in the early 19th century while a majority of the Malayalees were employed as junior officers, mostly made up of technical and clerical staff in the Railways, Public Works Department

and Post and Telegraph Department in the first quarter of the 20th century (Ramasamy, 1993; Puthucheary, 1993; Sandhu, 1969). A significant minority of the Malayalees also worked on the rubber plantations, occupying relatively more skilled labouring positions (Ampalavanar, 1981; Sandhu, 1969). The Sri Lankan Tamils were mostly employed in the area of subordinate managerial, clerical and technical posts in the estates especially during the period of 1880-1920 (Sandhu, 1993). As for the North Indians, the majority were the Punjabis. "In 1947 they numbered 30,592 or more than 72% of the total North Indian population in Malaya" (Sandhu, 1993, p. 161). The Punjabis were initially employed in services such as the police and military forces. As for the Gujaratis, natives of Gujarat, and Sindhis, natives of the Province of Sind, which is now part of Pakistan, they were part of the trading and money-lending groups in Malaya. Overall, it was estimated that between 1834 and 1937 about 30 million Indians migrated to different parts of the world, and about 24 million returned home during the same period (Jain, 1990, p.10). In the time span of over a century, around 6 million Indians remained in the colonial countries such as Malaya and Burma, making them their homes. The Indians in Malaya became Malayan citizens "following the liberalization of the country's citizenship laws in 1952 and 1957 which allowed non-Malays to become citizens of Malaya provided they fulfilled certain requirements" (Sandhu, 1969, p. 301). Citizenship saw the etchings of a new identity, one that

amalgamated Indian origins and new roots through its transplantation in the new land, Malaysia. The journey to nationhood would travel multiple routes, through the many and varied vehicles of individual identity. Nowhere is this more evidently and significantly expressed than in literary works. The ensuing section provides a glimpse into the role of the family house in the creative imaginary of three Malaysian Indian writers: K. S. Maniam, Rani Manicka and Preeta Samarasan.

FEATURES OF THE FAMILY HOUSE

Most discussions of the trope of the house in diasporic texts centre on its reflection of the politics of belonging. In the South Asian Diaspora, V. S. Naipaul's *A House for Mr Biswas* is often seen as the quintessential text that puts forth the journey towards home and belonging in the host land. As Vijay Mishra succinctly puts it, while for the people of Biswas' generation, first-generation migrants to new lands, the house became a signifier that suggested "an ownership through naming and transforming the landscape", for the new diaspora, the diasporas of metropolitan spaces, home takes on a different meaning as it becomes a status symbol, of a marker of how far one has come in materialistic terms (2008, pp. 202-203). We wish to add another dimension to this argument by investigating the transformation of the family house amongst the different generations of the South Asian diaspora in Malaysia and how this acts as a reflection of the changing features of the diasporic imaginary. We wish to reveal too

how as generations unfurl deeper into the depths of the land that has become home, the physical features become indicators of the extent to which the diaspora has developed into a heterogeneous community. In the context of the corpus of texts selected for this paper, the image of the family house in the selected novels by K. S. Maniam, Rani Manicka and Preeta Samarasan would give readers an idea to the heterogeneity of the writers' diasporic experience as the design and structure of the houses depicted in these stories are influenced by the culture that they are from, together with the culture that they are surrounded by. For example, in building a family house, first-generation diasporic Indians would be strongly inclined to build their homes with distinguishing features of traditional Indian houses. One such distinguishing architectural feature of Southern Indian houses is the veranda or *thinnai* (an open-walled, roofed porch). It is the front portion in one's house which functions as a temporary shelter before entering a house. The veranda acts as a space between the exterior and interior part of a house. Pillai (2007, p.98) states that the *thinnai* is significant because it "becomes the portal of folk memory, the space where the younger generation of the diasporic community is drawn into, and subsequently transformed by, the memories of the older generation". For the Indian community in Malaysia, the veranda is looked upon as one that bridges the older generation to the younger generation of Indians. Furthermore, as the Malays are the predominant ethnic group in Malaysia, the architecture of the

houses built or lived in by the characters in the novels discussed may also be influenced by that of the traditional Malay house. According to Lim (n. d., p. 16), a traditional Malay house is made of timber: "with a post and lintel structure raised on stilts, with wooden, bamboo, or thatched walls and a thatched roof, the house is designed to suit the tropical climate". Apart from that, since Malaysia was once colonised by the British, the influence of the English-style architecture may also contribute to the design of the houses found in these stories.

K. S. Maniam is one of Malaysia's most prolific writers and his stories centre around the history and problems of the Indian community in Malaysia. Maniam's *The Return* (1981) is hailed as one of the seminal creative works in English to have emerged out of the Malaysian Indian community. It revolves around the experiences of the narrator and protagonist, Ravi, from his humble beginnings in a rural working class environment and his subsequent social mobility through an education in English and the attendant communal and personal conflicts that beset him. Rani Manicka, on the other hand, is a promising and upcoming novelist who published her first novel, *The Rice Mother* in 2002. *The Rice Mother* has been translated into 17 languages and has gained international acclaim. The novel tells the story of four generations of a middle class Sri Lankan Tamil family's struggle in surviving through World War II, the Japanese occupation and post-war prosperity. It is the matriarch of the family, Lakshmi, who keeps the family together

during their hardship. Preeta Samarasan, who published *Evening Is the Whole Day* in 2008, is being hailed as one of the newest voices to emerge from the Malaysian Indian community. Her novel centres on the Rajashekarans, a wealthy middle class Tamil family in Ipoh in the 1980s, and is narrated from the point of view of the youngest child of the family.

As in many communities, class affiliations are always a significant factor that influences the dynamics of inter-communal experience. The differences in the class affiliations of the communities in each novel reveal many insights into the images of their house as these dwellings are very much influenced by their socioeconomic background. Furthermore, Maniam lives in Malaysia and Manicka has migrated to England while Samarasan resides in France, and it is the transnational status of Manicka and Samarasan that make up the different resonances from Maniam's homebound imaginary. Thus, the discussion of the three novels that follow will bear witness to the playing out of these very dynamics.

ROLE OF THE FAMILY HOUSE

One of the most significant creative enunciations of the intricacies of the early Indian immigrant experience of Malaya can be found in the works of K. S. Maniam. Maniam's works offer important insights into the ways in which he reconstructs the narrative of the pioneer Indian immigrants of Malaya. The Indian community started their lives in the indentured barracks or coolie lines and this community gradually

began to carve their own spaces which are very much evident in Maniam's *The Return*. In *The Return*, we are introduced to a descriptive image of a family house in the first few pages. Periathai, the matriarch of the family, builds a house for her family with evidence of strong Indian elements:

It had a large, cool hall, a small room and an old-fashioned, Indian cooking place. We, her grandchildren, enjoyed more the colourful entrance to this house. A double-pillared affair, it had strange stories carved on its timber faces...The walls, thinnai and even the kolam-covered yard appear insignificant. Some of the Ramayana episodes stood out with palpable poignancy: Rama challenged, bow and arrow at the ready, yet his brows lined with anxiety for the missing Sita. The sculptured, fold-like flames envelope Ravana's palace and threaten to engulf Sita's tender, shapely limbs and breasts. One pillar carried the creation of the Ganges, the cascading water stilled, another the typical, rustic look of the Indian village. (p. 4)

The pillars are described in great detail and it is clearly seen that Periathai still clings on to her Indian roots and traditions very strongly. The pillars are engraved with important events/scenes in India such as scenes from the Ramayana, the epic tale of good versus evil; the holy river, Ganges;

and even a depiction of a rural Indian village. While on one level the house may seem like an encapsulation of an India left behind, it will serve one well to note that the Ramayana has been hailed as one of the signifiers of the diasporic experience. Rama and Sita's exile in the forest is akin to the diasporic exodus. Thus we have the arrival of Periathai in the forest of Bidor. On the other hand, the image of the river can be seen as a metaphorical cleansing of the sins or of Rama reaching the river to be absolved of sin, "Rama, the mighty armed, reached the river Ganga, which is devoid of sins and which dispels all sins..." (Valmiki Ramayana, n. d.). In many senses the carvings on the pillars symbolise the attempt to immortalise the memory of the distant home, in concrete form within the new home. It also acts as a site that locates ancestral heritage for the future generation, inscriptions of ancestral legends and lived locations, a manifestation of the "fossilised motherland" that Vijay Mishra (1992) has spoken about. Although the concept behind Periathai's house is leaning towards India, it should be noted that Periathai, in her deathbed confession, gives her word to Ravi that she will never leave the land that she had grown to love and fought for till her last breath to have the land deed legalised under her name. Although the land may not be hers legally, her spirit will still belong to the land. Periathai, an immigrant, had made a home in Malaysia and from her dying words, the readers know that her allegiance lies with Malaysia, and not India.

Unlike the strong Indian elements found in Periathai's house, the space the young Ravi builds for himself as a child growing up in a hospital barrack leans towards a desire for assimilation into the dominant culture in the local landscape at the time, that of the English. The hospital barrack, a colonial imposition, has limited space, and this space is used for multi-purpose functions such as hall-cum-dining room during the day and bedroom during the night. Its limited space is a metaphor for the early experience of the Indian immigrants who travelled within the cramped spaces of the vessels that transported them from India to Malaya which resulted in what Vijay Mishra terms as 'trauma in the homeland' (2005). As a young boy, Ravi had to draw a line with a chalk in a corner of the front room and imagine it as his walls, and the space within this line, a room that he can call his and retreat to when he wants some privacy. The space created by Ravi reflects how the third generation, then young, appropriates 'a room of his own within that house' thus creating another perception of his own identity although the space that he creates is born within the colonial space. To further distance himself from his Indian identity, Ravi has pictures of the English countryside and snow-capped mountains pasted on the walls in his 'room' which points to the fact that his concept of belonging is moving towards the ideal of belonging, possession and home, in this case, Britain. Even in this limited space, Ravi cherishes his privacy and believes that to get out of his poor

lifestyle, he has to study hard as through education, he would be able to upgrade his standard of living.

Compared to Periathai and his father, Kannan, Ravi does not see the importance of owning land in Malaysia. Ravi's disdain of his father's effort to build a house clearly comes across when he returns from England to find his family has moved to a hut at the edge of a jungle. Readers are again reminded and given the picture of a jungle which goes back to the reference to Rama's exile in the forest. However, his father's hut is liberation from the hospital barrack as it is his own space. It also shows an engagement with the land as Kannan's hut is built using materials from the land. Kannan has toiled day and night to build a house for his family. Kannan does not want to die like his mother, a displaced person. Furthermore, Kannan also tries to convince Ravi of the importance of owning land in the country they migrated to but Ravi shows no interest in his father's efforts. Apart from that, Kannan grows his own vegetables and from its description, the land is rich and its soil fertile. By fencing the land, Kannan would also be able to claim the space as his private property. Owning a piece of land becomes important to the older generation of immigrants but not to the younger as Ravi only sees the importance of being educated to come out of the cycle of poverty within which his family is trapped. For Ravi, there seems to be no urgency for planting a stake in the land to call it his home. Thus, within one family, there seems to be different renditions of the concept of house: for Periathai, the concept of house

is ingrained in ties to India but her sense of allegiance is to Malaysia, whereas Kannan's concept of house is a sense of belonging in his new home, Malaysia, and Ravi's concept of home seems to be a leaning towards Britain.

In *The Rice Mother*, readers are given a description of the family house through the eyes of 14-year-old Lakshmi. Married off to a man 23 years older than her and brought to a new country, Malaya, Lakshmi was led to believe that her husband was a rich man and that she would live a comfortable life. In reality, she was brought to a small wooden house that did not even belong to her husband. Manicka describes the house as wooden and raised on low stilts, typical features of a traditional Malay house (Lim, n. d.). Unlike Periathai's house that has strong Indian features, the description of Lakshmi's house reflects a localised image. Similar to Maniam, Manicka also gives importance to religion as there are descriptions of a prayer altar with pictures of Hindu deities and dead flowers surrounding them, an indication of prayer rituals. Thus, while the exterior of the house is local, the interior reflects ancestral heritage. Furthermore, the interior shows the house to be modern. Facilities such as shelf and a bathroom are a luxury that Periathai in *The Return* could not afford. Lakshmi has clean running water from a tap in her bathroom as compared to Periathai who only has a 'communal bathshed' (Maniam, 1981, p. 5). Lakshmi's bathroom is located inside the house whereas Periathai's bathshed is not only outside, but anyone in the surrounding

area could have access to it. Apart from that, Lakshmi has a shelf that she can use as an altar whereas Periathai has to make do with an 'earthen dais' (Maniam, 1981, p. 5) to conduct her prayers. Lakshmi's house not only reflects modernity in its facilities, it also shows the social class she belongs to. Lakshmi's husband, Ayah, is a clerk, whereas Periathai is an independent worker and her son, Kannan, works as a dhobi for the hospital. Ayah's position would place him in the same social class as Menon in *The Return*, the middle-class group, hence the recourse to modern facilities. As soon as Lakshmi arrives in her new home, she begins to cleanse the house of any dirt or memories of the past. The house, described as her "new toy", indicates that she would etch new memories.

Although there seems to be quite a difference between Lakshmi's house and Periathai's house in *The Return*, one similarity that we find is the role of the veranda. In both *The Return* and *The Rice Mother*, the veranda seems to be an important feature. In *The Return*, the *thinnaï* (veranda) is the place where Periathai tells stories to the younger generation, reminding them of their ancestral land through these stories (Pillai, 2007). In *The Rice Mother*, a connection between the younger and older generation is established in the veranda. Starting with the story of Ayah, Lakshmi's husband, down to that of Nisha, her great-granddaughter, the veranda is privy to the family's happiness and sadness. The veranda has always been Ayah's refuge and it is here that his daughter-in-law and granddaughter

sit and talk to him on many accounts, such detailed below:

Rani, her daughter-in-law...sat chatting in English with Ayah in the living room or on the veranda. (Manicka, 2002, p. 268)

Often Grandad and I sat quietly on the veranda watching the evening sun turn red in the sky. (Manicka, 2002, p. 311)

It is at the veranda that Lakshmi bids goodbye silently to her second son, Jeyan, when he leaves the house, "Mother sat on the veranda watching him leave with the strangest expression on her face" (Manicka, 2002, p. 282). The veranda is also where Lakshmi waits eagerly for her granddaughter every school holiday: "Breaking free from Aunty Lalita's hold I would run towards the figure on the veranda" (Manicka, 2002, p. 308). Lakshmi's excitement can be clearly seen in the image of her hugging her granddaughter in her arms in the veranda.

It is also at this very same veranda that Lalita embraces Nisha in her arms towards the end of the novel, "I knocked on the door and my Great-Aunt Lalita appeared. She held me in her feeble arms and she looked so old I didn't recognise her at all" (Manicka, 2002, p. 459). Manicka poignantly paints the same picture of a grandmother hugging her granddaughter, only this time it is not Lakshmi embracing Dimple but Lakshmi's daughter, Lalita hugging Nisha, Dimple's daughter. Thus the

veranda plays a significant role in the lives of each generation of Lakshmi's family.

Apart from Lakshmi's house, there is the other family house that belongs to her granddaughter, Dimple. Lara is the name given to the house that Luke, Dimple's husband, builds for her. Significantly, Lara is the family name of a powerful Spanish family that rose to power in the late eleventh century and "(i)t is this romance of treachery, love, and revenge, spanning the gulf between Lara and Cordoba, which accounts for the village's modern name, Lara de los Infantes" (Doubleday, 2001, p. 3). How apt to name the house Lara as it is treachery, love and revenge that destroys the lives of Dimple and Luke. Unlike Lakshmi's small wooden house, Lara has wrought-iron gates and is described as rather large:

It was very large, brand new and set on hilly ground.

...At the touch of a remote control the imposing gates swung open...I had never seen the gates of a residential house operated in such a manner before. We walked along a driveway flanked on either side by conifer trees.

*...At the end of the curved driveway on a large piece of land dotted with big, shady trees, a house white and beautifully decorated with cornices and thick Roman pillars rose grandly from the ground. And at the entrance stood two huge stone lions...a statue under the shade of an *angsana* tree. (p. 330)*

The house is built in accordance to the era of technological development in the West and at a time when Malaysia was starting to enjoy the development as a post-independent country, growing from being an agricultural state to an industrial economy in the late 70s. Thus the readers are able to share Dimple's surprise at having gates being opened using a technological device rather than manually. Apart from highlighting the shift from agriculture to technology, it is also the first indication of Luke's wealth. The image of the driveway being 'flanked on either side by conifer trees' (Manicka, 2002, p. 330) gives the readers a picture of being in a countryside in cold countries rather than in Malaysia as conifer trees are more commonly found in Northern America. However she does mention an *angsana* tree somewhere near the entrance of the house, thus adding a local touch to the house. The readers are brought back to the image of a time in Ancient Rome with her description of "thick Roman pillars" rising "grandly from the ground" (Manicka, 2002, p. 330). The pillars, unlike the pillars described in Maniam's *The Return*, are 'thick', 'Roman' and 'grand' which is almost like a description of the ancient temples built in Rome and not a description of a house. However, the inclusion of the image of two huge lions made of stone standing in front of the entrance adds a touch of Asian culture, in particular, Chinese culture. According to Ma (2011), in the Chinese culture, it is believed that stone lions are a "symbol of grandeur and can often be seen at the entrances to temples, palaces or mansions,

and prominent locations...meant to keep away evil spirits and guard the location”.

Although the outer appearance of the house has a combination of local and Western influence, the inner part of the house seems to be devoid of any local touch except for the painting of Dimple, and that too is located on the far wall, attesting to its being somehow less significant:

...The lofty ceiling was painted with cherubs and robed figures from the time of the Renaissance. A curving staircase in the middle led to the first floor. Under our feet was an unbroken expanse of black marble and on the walls hung sumptuous paintings.

...on the far wall, a very large painting of me...

‘Look, this is inspired by Nero’s golden palace. Press this button and the mother-of-pearl squares in the ceiling slide back and look...’

...out sprinkled drops of perfume.
(p. 331)

Manicka’s mention of the Renaissance era brings the readers back to a time of the revival of elements of ancient art with modernity. It gives an image of classical, breathtaking paintings from the 15th to 16th century by famous artists such as Leonardo da Vinci, Michelangelo and Raphael. Apart from the 15th century Renaissance era, the house also has the characteristics of architecture of nearly 2000 years ago. The construction of the ceiling was a replica

of Nero’s golden house which was built by the infamous Roman emperor in 60 A. D., “There were dining-rooms with fretted ceils of ivory, whose panels could turn and shower down flowers and were fitted with pipes for sprinkling the guests with perfumes” (Suetonius, 1914, p. 137).

Lara has never been a home for Dimple as while it is a luxurious house, it serves merely as a building and not a home or family house for Dimple, and she does not find happiness there. Dimple has lost her Indian identity amidst other cultures, namely, European and Chinese. Although this is a dilemma experienced by some of the younger generations who become lost and confused with their hybrid states, Maniam (1997), in his discussion of the new diasporic man, celebrates hybridity as being an inevitable and inescapable part of most Malaysians. Unlike Periathai in *The Return* and her own grandmother, Lakshmi, Dimple does not have any ancestral heritage in her house that she can hold on to, thus losing her sense of identity. In the description of the house belonging to the younger generation, there is no trace of Indian cultural identity except for the reference to the Taj Mahal. Although the Taj Mahal is located in India, it is of Mughal era, representing Islamic architecture. Thus the role of the family house belonging to the younger generation, with its European and Chinese architectural style rather than Indian, shows a dissociation with the family’s ancestral land.

In *Evening Is the Whole Day*, readers are introduced to the images of different sizes and styles of houses found in one

particular street in Ipoh on the second page of the novel. This description informs us that in Samarasan's novel, the architecture draws on various cultures and their houses. The houses described reflect the races in Malaysia as there is mention of houses built according to Malay and Chinese architecture. The family house, known as the 'Big House', is described using adjectives such as 'black gates', 'robust greenery', 'bright blue bulk' and is said to dominate the street they live on (Samarasan, 2008, p. 2). The description is almost as if the house is intimidating and there is no cosiness or comfort that one often finds when reading descriptions of family houses. The vivid colour of the house, 'bright blue', is a stark contrast to the hospital barrack in *The Return* which is described as "squalid, green, and over-crowded" (Maniam, 1981, p. 50). While Samarasan gives the image of a house that is too big for its household with its vibrant colours, Maniam paints a picture of a dirty, small house.

Apart from that, the capital letters used to refer to the family house in Samarasan's novel indicates that there is no emotional attachment to the house as the term serves only to express the vastness of the building. The journey towards the ownership of the Big House is portrayed as rather effortless too. Unlike in *The Return*, where Maniam highlights the struggles of an immigrant family to own a house despite living in the land for a long time, in *Evening Is the Whole Day*, Samarasan gives readers an account of how a colonial house comes into the possession of an Immigrant coolie's son

within a time-span of only 57 years. Known as Tata, the coolie's son works his way from being a clerk at a steamship company to owning his own shipping company and is even able to send his son to read law in Oxford. Tata needs a house that will show his prosperity in the country he migrated to. He buys a colonial house to lay a stake in his new country, to show a shift of ownership from a white man (coloniser) to an Indian man (the colonised).

It is also interesting to note that there was light in the Rajasekharan's house at the exact moment that there was light in the colonial cricket ground when Tunku Abdul Rahman announced the independence of the country. The immigrant family who were brought in by the colonisers have found a new home in the country they migrated to and just as how Malaya gained its independence from the British, the Rajasekharan family, although they come to Malaya as dockyard coolies, are able to establish their stake in the new land. Thus, Samarasan's family house is used as a metaphor for the advent of freedom from colonial rule, as 31 August, 1957 is the day of Malaya's freedom, Independence Day.

Tata extends the house with English-style renovations by hiring a few architects as he wants only the best for his family house. All the rooms that Tata adds to the house serve to show Tata's wealth and status in society. Samarasan's purposeful mention of a claw-foot bathtub and Aga range kitchen appliances indicates elegance and the expensive taste of the Rajasekharans. Added into this is an orchid conservatory

which is unnecessary as the climate in Malaysia is hot and humid, together with a music room-cum-smoking room where Samarasan points out that no one smoked or played music, thus rendering all those added renovations as unnecessary and a waste of money and time. With all the additions, not even one room is allocated for prayers, unlike in *The Return* and *The Rice Mother* where prayer altars and deities are mentioned. The Big House is almost devoid of Hindu cultural elements and is a modern, Anglo-Saxon construction. However, Tata does try to add a touch of local design into the construction of the house, according to Malay architecture:

Tata had the new wings built in a proud local style: solid wooden slats on a concrete base, patched willy-nilly onto the austere symmetry of the original grey stone structure, so that in less than two years the house metamorphosed into something out of an Enid Blyton bedtime story. Unnecessary corridors met each other at oblique angles. Additions, partitions, and covered porches seemed to rise out of nowhere before the eye. Green mosquito netting thumbed its nose at the Batternburg lace curtains in the next room. Sweat and steam and coal smoke from the hot Indian kitchen invaded the immaculate English kitchen and smeared its shiny surfaces. (Samarasan, 2008, p. 26)

The word 'proud' used to explain the local style indicates that the house is built in a grand manner and apart from the wooden slats, the only other indication that the house has a local feature is the green mosquito netting against the sophistication of the Batternburg lace curtains. The only thing that seems out of place in the entire house would be the green mosquito netting, which is a necessity as there are a lot of mosquitoes in Malaysia. Unlike *The Return*, in which the Indian culture is obvious through the carvings of stories from India and the mention of *thinnai* and *kolam*, *Evening Is the Whole Day* lacks a stamp of Indian identity in its architecture. The only mention of an Indian feature in the image of the house is the Indian kitchen whose smoke has tarnished the beautiful tiles of the English kitchen. However, the Indian kitchen is not even part of the house as it is located outside the house. Furthermore, the mention of Enid Blyton stories is a reference to the Western influence on the young children as compared to the mention of the Ramayana stories in *The Return* which is steeped in Indian tradition and culture.

Apart from the mention of the Indian kitchen, the vivid paint on the exterior of the house is another characteristic of Indian identity:

Tata's last home-improvement venture before he died was to paint the outside of the house an unapologetic peacock blue, as if to stamp upon the building his ownership, his nation's liberty and his own. (Samarasan, 2008, p. 26)

It is interesting to note that Samarasan has chosen peacock blue as the colour of the family house as the peacock is the national bird of India and “symbolizes the qualities like beauty, elegance, pride, delight, spirituality and mysticism” (Khanna, 2007). Furthermore, Samarasan states that the choice of colour is a mark of “his nation’s liberty”. Which nation’s liberty is Samarasan referring to, India or Malaysia, as one of the colours in the flag of Malaysia is dark blue canton and not peacock blue? Painting the house in such bright colour is Tata’s way of planting his stake in the land that he considers his home. There is also a reference to Malaysia’s five-year-economic plan as the house is repainted every five years but with the same colour. The choice of the same paint is a metaphor for the unchanging ethnic stamp.

CONCLUSION

If we were to take a panoptic view of the family houses discussed above, we would see that they are not aligned to a common architectural blueprint. Each narrative presents the construction of the diasporic home according to the materials of family memory, and as these memories travel the generational distance the resultant edifice emerges out of a hybrid compound that reconstructs ancestral architectural designs with other structural designs. In the case of the diasporic Malaysian Indian experience, the two most influential prototypes would be either that of the British colonial prototype or the Malay architectural prototype. The

further afield these memories travel, the fainter the pull of these prototypes, and they become inevitably replaced by the modern globalised architectural designs, ranging from European villas to postmodern constructions of an extremely hybrid ensemble.

In sum, this discussion reveals the plurality that is etched on the grounds of the Malaysian Indian diasporic literary sensibility, and this undoubtedly, will colour to the various articulations of house and dwelling, key indicators of the experience of diaspora. This said, it would be interesting to find out the role of family houses in the writings of Malaysian diasporic Chinese writers such as Tash Aw and Tan Twan Eng. We thus bring this discussion to a close by emphasising that the Malaysian Indian diasporic imaginary is heterogeneous.

REFERENCES

- Ampalavanar, R. (1981). *The Indian minority and political change in Malaya, 1945-1957*. Oxford: Oxford University Press.
- Arasaratnam, S. (1993). Malaysian Indians: The formation of incipient society. In K. S. Sandhu, & A. Mani, A. (Eds.). *Indian communities in Southeast Asia*. Singapore: Institute of Southeast Asian Studies.
- Doubleday, S. R. (2001). *The Lara family: Crown and nobility in medieval Spain*. Harvard: Harvard University Press.
- Khanna, P. (2007). Peacock: The national bird of India: The diadem of India. *Alumbo.com*. Web. 19 Nov. 2012.
- Lim, J. Y. (n.d.). The traditional Malay house. *Under one roof*. Web. 21 Nov. 2011 .

- Ma, R. C. (2011). The significance of stone lions in Chinese culture. *Helium.com*. Web. 27 Dec. 2012 .
- Maniam, K. S. (1981). *The return*. Kuala Lumpur: Heinemann Asia.
- Maniam, K. S. (1997). *The new diaspora*. In D. H. McMillen (Ed.). *Globalisation and regional communities: Geoeconomic, sociocultural and security implications for Australia*. Toowoomba: University of Southern Queensland Press, pp. 18–23.
- Manicka, R. (2002). *The rice mother*. London: Hodder & Stoughton.
- Mishra, V. (1992). The Girit ideology revisited: Fiji Indian literature. In e. Nelson. (Ed.). *Reworlding: The literature of the Indian diaspora*. New York: Greenwood Pub Group.
- Mishra, V. (2005). *The diasporic imaginary and the Indian diaspora*. Victoria University of Wellington: Asian Studies Institute.
- Mishra, V. (2008). 'The familiar temporariness' - Naipaul, diaspora and the literary imagination: A personal narrative. In Rajesh Rai & P. Reeves (Eds.). *The South Asian diaspora: Transnational networks and changing identities*. Routledge, Abingdon, Oxon, pp. 193-208.
- Pillai, S. (2007). *Colonial visions, postcolonial revisions: Images of the Indian diaspora in Malaysia*. United Kingdom: Cambridge Scholars Publishing.
- Puthuchery, M. (1993). Indians in the public sector in Malaysia. In K. S. Sandhu, & A. Mani, A. (Eds.). *Indian communities in Southeast Asia*, pp. 334-66. Singapore: Institute of Southeast Asian Studies.
- Ramasamy, P. (1993). Socio-economic transformation of Malaysian Indian plantation workers. In K. S. Sandhu, & A. Mani(Eds.). *Indian communities in Southeast Asia*, pp. 314-33. Singapore: Institute of Southeast Asian Studies.
- Samarasan, P. (2008). *Evening Is the Whole Day*. London: Fourth Estate.
- Sandhu, K. S. (1969). *Indian in Malaya: Some aspects of their Immigration and Settlement (1786-1957)*. Cambridge: Cambridge University Press.
- Sandhu, K. S. (1993). The coming of the Indians to Malaysia. In K. S. Sandhu, & A. Mani (Eds.). *Indian communities in Southeast Asia* pp. 151 – 189. Singapore: Institute of Southeast Asian Studies.
- Suetonius, T. (1914). The life of Nero'. In J. C. Rolfe. (trans.). *Lives of the Caesars*. Loeb Classical Library, 87-187. Web. 27 Dec. 2012 .
- Valmiki Ramayana. (n.d.). Ayodhya Kanda in Prose. *Valmikiramayan.com*. Web. 4 Dec. 2012.

Classroom Talk – A Significant Consideration in Developing an Analytical Framework

Dass, L. C.*, Normah, A., Arumugam, N. and Dillah, D.

Academy of Language Studies, Universiti Teknologi MARA, 40450 Shah Alam, Selangor, Malaysia

ABSTRACT

This paper is part of a larger study in which two frameworks were developed in order to analyse data sets gathered in a Malaysian undergraduate setting. The broader aim of the research is to study the degree of transferability of an interactive pedagogy developed by Western researchers in a Malaysian classroom setting. The first paper discussed how a framework was developed from Project Zero research findings. The subsequent paper will show how an analytical framework derived from the first and second (present) papers can be used to analyse data sets and provide answers to the research questions raised in the study. The focus of this second paper, however, is to develop one framework, for which literature by prominent researchers in classroom discourse is considered. This paper specifically deals with various aspects of classroom discourse ranging from the importance of language and the use of right language to stimulate student thinking to improving teaching and learning by employing suitable classroom discourse. This is followed by a table listing episodes of classroom interaction that research shows is relevant to enhance classroom learning.

Keywords: Classroom discourse, pedagogical content knowledge, Project Zero, higher order thinking, pedagogical talk

ARTICLE INFO

Article history:

Received: 23 December 2013

Accepted: 26 February 2014

E-mail addresses:

laura404@salam.uitm.edu.my (Dass, L. C.),

norma034@salam.uitm.edu.my (Normah, A.),

nalini@salam.uitm.edu.my (Arumugam, N.),

doreen@salam.uitm.edu.my (Dillah, D.)

* Corresponding author

INTRODUCTION

The broader aim of this research is to study the degree of transferability of an interactive pedagogy developed in the West in a Malaysian classroom setting. As this study is based on the social constructivist theory, data are analysed using a social constructivist framework developed from classroom discourse literature by prominent

researchers in this area. Key researchers in classroom discourse include Cazden (2001), Mercer (2000; 2009), Alexander (2006; 2012b), Wegerif and Dawes (2004), Barnes (1992), Wells (1992) and Norman (1992), among others. Literature by these key researchers was looked at to develop an analytical framework, which then served as a comprehensive lens for viewing the kinds of interactions that took place within a data set. This framework (Table 1) combined with that built from Project Zero (PZ) research findings provided a comprehensive lens through which data sets gathered in a Malaysian undergraduate setting could be analysed. The data consist of a video of classes in session, an interview with student and teacher participants as well as researcher observation. The final analytical framework derived was then utilised to provide answers to research questions raised in the study. A sample of a section of the framework built from PZ research (reported in the first paper) is included (Appendix 1) to aid in understanding the processes involved in this study. A sample of how the final analytical framework will look like, as will be discussed in the third paper, is also included (Appendix 2). Apart from serving to further highlight the significance of the present paper in this trilogy, the appendices mentioned above also depict the extent of the study undertaken, which in turn explains the need for this three-part analysis.

PZ research is considered briefly in this paper as an understanding of it is pivotal in making sense of classroom discourse. PZ research initiatives are carried out by the

Harvard Graduate School of Education; it is particularly employed as a reference point because it is a well-established classroom research model with interaction as a key element. As the focus of this paper is framework development, research questions will only be discussed in the next paper.

This paper is focused on discussing in depth the literature on classroom discourse and is divided into several sub-sections that deal with various aspects of classroom discourse.

IMPORTANCE OF CLASSROOM DISCOURSE

As corroborated by Project Zero research findings, Cazden (2001) recommends various ways in which changes can be made to improve teaching and learning. She opines that changes in the nature of the workplace and civil society have affected the way knowledge and learning are conceived. This has led to education today placing greater importance on the intellectual processes rather than the product. As such, teachers are urged to switch to classroom discussion in order to inspire and develop higher order thinking. This is a move away from the traditional classroom that practises the three-part pattern (Initiation/Response/Evaluation-IRE). The importance of language has been spoken about by many a researcher for a long time. Vygotsky simply puts it this way, "Children solve practical tasks with the help of their speech as well as with their eyes and hands" (1978, p.26). Conversations with people in similar

settings have been observed by Bruner and other developmental psychologists to help form young children's personal growth (1990). Halliday (1993) establishes that for children, language learning lays the very foundation for all kinds of learning to occur. In his words, "When children learn language...they are learning the foundations of learning itself" (pp. 93–116). Echoing this, Alexander (2006, 2012b), argues that the case for pedagogical talk, which he terms as "pedagogical dialogue" is based on both research evidence and logic. According to him, learning that involves learners' attention and captures their interest and has two-way interactions rather than just one, is more likely to bring greater benefits to learners. He asserts that:

...dialogic pedagogy works better than a monologic one...for it touches on the nature of brain and mind, on the relationship between language and thought and on the complex interweaving of the cognitive, social and cultural in human development and learning. (2006, p. 4)

DEVELOPMENTS IN CLASSROOM DISCOURSE STUDIES

There have been groups lobbying for an increase in the amount of talk time in the classroom since the 1990s; among them is The National Oracy Project 1992 which favours using talk during classroom activities as a means of improving learners' language. Barnes (1992) spells out the need for teachers to know that the way

they listen and respond to students' talk is used by learners as strong indicators of the manner in which they should react in the classroom. This he says has, in turn, substantial influence on the way learners talk in the lessons that follow apart from other factors such as the context and the requirement of the lesson. As such, Barnes (1992) recommends that teachers explain clearly the reasons why learners should be involved in various types of conversation as well as the usefulness of conversation and that language is taught within context. Alexander (2012a) states that over the last 40 years, teachers have been aware of the unique and monumental role played by talk in learners' development. He further adds there is robust proof from over 20 major studies conducted worldwide that high level classroom talk enhances standards in subjects like English, Mathematics and Science. Now there is a great amount of evidence pointing to the measurable impact that high-quality classroom talk has on the standards of student achievement in core subjects (Alexander, 2012; Mercer & Littleton, 2007).

IMPORTANCE OF RELEVANT CLASSROOM DISCOURSE

Many education systems around the world give high priority to the achievement of literacy and numeracy in their schools and very often the success of an education system is judged by the rate of accomplishment of students in these skills. Surprising as it may be, talk, which comprises the very medium necessary to access education

itself, is devoted the least attention in schools. Wegerif and Dawes (2004) reason that perhaps the rationale for this omission is that children arrive in school displaying an impressive capacity to talk; however, according to Wegerif and Dawes, this is still insufficient as there is much to learn in terms of talking appropriately and effectively in a wide range of social and academic contexts. As important as the realisation that talk is a necessary part of classroom teaching, the importance of learners acquiring the discourse relevant within the discipline cannot be downplayed, as Cazden (2001) discusses. She differentiates classroom discourse from the informal talk students engage in outside of school; the greater the difference between the two, the greater the effort that is needed to enable students to learn the new role of talk. Educators from different countries, such as Douglas Barnes from Britain and Lisa Delpit, an African American, express the importance of explaining the “ground rules” (Sheeran & Barnes, 1991) to achieving the spoken and written skills of these “discourses of power” (Delpit, 1995).

Cazden (2001) urges that the new curriculum has to include not only the cognitive process of learning but also the social processes of discourse and that the new role of teachers is to become teacher researchers in their own classrooms. The task of learning to talk effectively is a difficult and lengthy process which requires teachers to help learners realise the kind of talk that is relevant to benefit most from the classroom (Wegerif, 2004). In his words, “The teacher

has a crucial role in making the thinking aims of activities explicit, modelling good thinking strategies and designing learning activities so that skills learnt in one context are applied in new contexts” (p.59). This is substantially different from the focus of the Visible Thinking project, which is devoted to making thinking explicit in the classroom. However, the language appropriate for use in the classroom is not discussed by the authors of the VT project mentioned above.

NEW CONTEXTS FOR STUDENTS’ LANGUAGE DEVELOPMENT

Cazden (2001) and Wake (2006) argue that adjustments to the language use in classrooms are important to strengthen the context in which students’ language progresses. Cazden puts forth that oral and written communication skills are increasingly gaining prominence in the world today both for purposes of work and social needs. Wegerif and Dawes (2004) say the benefits of talking effectively surpasses the classroom to the community, such as respect and empathy for others, awareness of the need for fairness and tolerance for differences and, most importantly, ability to discard the use of force and embrace the softer persuasive approach. Cazden (2001) strongly views that schools hold the task of establishing environments that allow students to use words of their choice that they are comfortable with to express their ideas. For many decades, the prime issues in education have been the consideration of dialect variations in the teaching of language skills of standard English. The National

Research Council of America reports suggestions made by linguist, William Labov, to alleviate reading problems in young children (Snow, Burns & Griffin, 1998). According to Labov, the principles that need to be employed are to “distinguish between mistakes in reading and mistakes in pronunciation” and to “give more attention to the ends of words”, where variation in pronunciation is more apparent (Snow *et al.*, 1998, p. 241- 242).

‘Talk Lesson’, a programme developed by Mercer, Dawes, Wegeriff and Littleton for children aged 8 – 11, is designed to create an understanding among learners that certain ways of using language in joint activities could lead to better reasoning and problem solving (Mercer, 2000; 2009). Mercer adds that it is also a way of overcoming unsuccessful collaborative activities caused by ineffective communication. In support of the ability of talk lesson in bringing out the potential that lies within the students, Mercer (2000; 2009) says the talk lesson enables students to exchange views, make individual thinking and reasoning visible to others, debate over differing opinions while substantiating their own and build upon their knowledge using one another’s ideas. According to him, this participation in group problem-solving activities enables students’ individual reasoning skills to develop, which corresponds with Vygotsky’s assertion of a link between social activity and individual development. Wegeriff and Dawes (2004) deduce that if Vygotsky’s claim were true, that by taking part in logical arguments, children are learning to think rationally

while alone, then children should be taught the ground rules for effective dialogue with others in order to enable higher order reflection to take place internally.

DISCOURSE IN NON-TRADITIONAL VS. TRADITIONAL CLASSROOMS

This sub-section discusses the various facets of the role of the teacher that is expected to come into play to facilitate and move away from the transmission approach to teaching.

Teaching Methods

The initiation of a venture called The National Oracy Project (1992) was an indication of the growing realisation of the important role played by oracy in student learning alongside literacy and numeracy. The National Oracy Project believes in the potential of collaborative learning through talk by learners (Mercer, 1992). It emphasises the importance of giving learners autonomy over their own learning and urges teachers to value learners’ language ability. Mercer (1992; 2000; 2009) further argues that the teaching method employed by the teacher is important as it has a significant impact on what is learned and how it is learned. He views that a good teaching method takes into account the needs of learners, and teachers need to continuously observe and identify with learners’ understanding in order to expand their understanding.

Cazden (2001) says one of the major ways in which a non-traditional classroom differs from a more traditional one is the role of the teacher, which diverges in the

following aspects. To begin with, the teacher accepts alternative answers given by students but she also encourages comparisons and justification. This enables students to realise the importance of explaining their answers and the need to listen and make reference to peers' opinions. Next, the ratio of teacher talk to student talk is reversed: in the traditional classroom, the teacher talks for two thirds of the class time but this is now reduced while students' response time is extended. Yet another aspect is the need for the teacher to understand student understanding of the lesson. In order to achieve this, the "pedagogical content knowledge" (Hashweh, 2005; Hill, Ball & Schilling, 2008; Loughran, Berry & Mulhall, 2006; Loughran, Mulhall & Berry, 2008; Shulman, 1987) of the teacher is important. This will enable the teacher to see the value behind students' opinions even though they may not be well expressed. Finally, students should discuss and validate answers and justifications as a group instead of solely depending on evaluation by the teacher.

Alexander (2006) has devised a dialogic teaching pedagogy constructed upon psychological and pedagogical evidence that is made up of a three-part repertoire based on five underlying dialogic principles. The first part of the dialogic repertoire i.e. the teacher needs to encourage the different kinds of 'learning talk' that are important for students to master e.g. the skills to narrate, explain, question, answer, analyse, speculate, imagine, explore, evaluate, discuss, argue, justify and negotiate. The characteristics that need to be nurtured

alongside these are willingness to listen, open to new ideas, to think and to give others time to do the same. The second part of the dialogic repertoire i.e. teachers acquire the five types of 'teaching talk' e.g. rote, recitation, exposition, discussion and dialogue. The third part of the dialogic repertoire i.e. the five interactive strategies that can be carried out in a classroom e.g. whole class teaching, group work led by the teacher, group work on set collaborative tasks led by the students themselves, one-to-one discussion between students and one-to-one discussion between student and teacher.

Alexander (2006) further substantiates his stance by offering five principles in which interaction needs to be grounded to make classroom discourse truly dialogic. Firstly, teacher and students attempt learning tasks **collectively**; secondly, teacher and students listen to each other, share ideas and are open to new suggestions, **reciprocally**; thirdly, students are able to voice their opinions freely without the fear of being ridiculed as a **supportive** environment has been established in which team work prevails; Fourthly, teacher and students construct on individual as well as shared ideas and form logical lines of thought and ask questions **cumulatively**; and fifthly, teacher plans and directs classroom discourse towards set educational goals **purposefully**.

Organisation of Classroom Talk and Peer Listening

In discussing elements of classroom discourse that can be altered in order to

make classroom talk more effective, Cazden (2001) believes that the idea behind the change is both educational and equitable opportunities to learn. This, she adds, requires teachers and researchers to observe who participates in classroom discussion, how they do it, who does not and why this is so. Unlike in the traditional classroom, where the teacher holds absolute control of the right to speak, though not all teachers would choose to exercise those rights all the time, here Cazden (2001) talks about the *speaking rights* (p.82) of students i.e. that students should be given opportunities to speak during classroom activities.

Cazden (2001), in adding more to a point already made, mentions that there are many ways to organise opportunities to speak, some of which are as follows. Firstly, teacher nomination according to seating positions addresses the issue of inequality as a result of “deregulating” classroom discourse. Next, encouraging “handing off” allows students to select the next speaker. Another would be the use of the ‘talking stick’; the student who receives the stick gets the opportunity to speak but can choose to utilise the opportunity or to pass it on. Lastly, the activity opening up an issue to the whole class requires all the students to take a stance on an issue. The author concludes by saying that teachers have the responsibility to make peer listening happen besides being careful listeners themselves because learning takes place while students are discussing problems in groups compared to while they are working individually. The recognition of the benefits of organising

good classroom talk by the teacher is not new, as shown by the literature. Deborah Schifter (1997), an applied mathematician and staff developer, reflects on how her former listening habits changed:-

I'm [becoming] able to see how individual kids are thinking and see what concepts are troublesome for kids to make sense of...I feel like I'm getting more skilled at finding out what kids do 'get' rather than just thinking 'they don't get it'. (p.16)

Teacher's Revoicing, Questioning and Waiting Time

Apart from organising opportunities for learners to speak and listen, teachers' revoicing, questioning and wait time serve many important roles in teaching and learning. O'Connor and Michaels (1996) mention that teachers' revoicing has many purposes. He points out that by repeating students' ideas to the class, the teacher actually summarises and reformulates the points uttered by students. In the second place, reconceptualisation allows for “a fusing of the teacher's words, register or knowledge with the original intent of the student” (O'Connor & Michaels, 1996, p. 81). Thirdly, revoicing, which is gaining in popularity, is essential for constructing common knowledge and building a community of learners.

According to Piagetian Eleanor Duckworth (1981), teacher questioning for the purposes of assisting and assessing student learning is important. She cites an

example where a conversation with a child that focuses on trying to make sense of the child's understanding is in itself a process which boosts the child's understanding. These types of questions are also known as metacognitive questions in which learners' attention is drawn to their own thinking and awareness. For example, 'What do you mean?'; 'How did you do that?'; 'Why do you say that?'; 'How does that fit in with what was just said?'; 'I don't really get that; could you explain it another way?'; 'Could you give me an example?'; 'How did you figure that out?'

The Initiation/Response/Evaluation or Initiation/Response/Feedback (IRE/IRF) method of learning in the traditional classroom is often called to question for the inauthenticity of its questions. The value of any question lies in its contribution towards student learning; in a non-traditional classroom, teachers are often urged to ask authentic questions or natural questions i.e. questions to which they do not already know the answers (Cazden, 2001). Equality in a dialogic classroom is seen when not only learners hear out the teacher but the teacher too asks authentic questions and is genuinely interested in what the students are saying and thinking (Alexander, 2006; 2012b). Nystrand showed through his large pretest-posttest study that by asking authentic questions, teachers supported students' thinking, and this led to successful and real learning (Nystrand *et al.*, 1997; Cazden, 2001).

However, Alexander (2006; 2012b) cautions that while good questioning skills

have a place in education, employing even the most well refined questioning techniques will not yield learning benefits if the answers provided are not taken to a higher level to provoke further thinking or questioning. As Bakhtin (1986, p.168) puts it, "If an answer does not give rise to a new question from itself, it falls out of the dialogue."

Assigning Students Intellectual Roles

In theory, when an idea comes from a less authoritative figure such as a peer, students will be quick in trying to reason it out conceptually and verbally or argue with the peer, which they may not be so ready to do if it comes from a more authoritative figure such as a parent or teacher (Cazden, 2001). Her finding indicates the different intellectual roles students can assume in pair or small-group activities. Spontaneous helping of each other is illustrated by Cazden (2001) with an example: when a fifth grader in a central Los Angeles school was required to record words and illustrations that depicted the desert (after a class trip), she asked peers for help in remembering a word. The "socially shared cognition" with peers helped the students as they used one another's memories as word search resources. This in turn enabled the student to succeed in her word search.

Another intellectual role students can assume in the classroom according to Cazden (2001) is tutoring another student when assigned to by the teacher. The initial awareness of the responsibility of having to teach others later leads students to take their own learning seriously. This helps 'tutors'

find a new dignity in seeing themselves as experts and resource persons even as their teachers observe an increase in their keenness to participate in the class as well as to assume lead roles. It is a good opportunity for students to give directions instead of receiving them and to ask questions instead of having to answer them. Teachers also could rely on these observations to pitch their expectations of their students. A third function refers to reciprocally providing a 'critique' of one another's work (as in peer writing conferences). Critique differs from criticism in that it is about work still in progress given by a colleague to another and is reciprocal, while criticism is given by professionals on completed work and is one way. The fourth and final role is collaborating as presumed equal-status learners on assigned tasks. Webb and Palincsar (1996) sum it up as, "The long list of group and classroom features provides a menu of possible ways to enhance the quality of collaboration in the classroom" (p. 867).

Cazden (2001) summarises some of the features of a non-traditional classroom either taken from her own studies or those done by others as follows. In non-traditional classrooms, the line between teacher-directed lessons and learning through peer group interactions are becoming blurred because the teacher is less authoritarian and there is an increase in student-student interaction. Examples cited are Gallas' non-traditional sharing time and Lampert's non-traditional lessons in which students are required to respond to both peers and

teacher; teachers intentionally 'revoice' students' ideas during a discussion to help them direct their ideas to the class; reciprocal teaching (RT), where the teacher initially leads the discussion but gradually intends for students to take over the task; and Brown's Community of Learners (COL) classrooms that have various frameworks that exemplify the many innovations in classroom organisation and patterns of participation.

There are some suggestions of ways around overcoming issues that arise concerning variation in language. Janet Maybin (1992), in her article 'Children's Language Practices at Home and School' mentions that bilingual children are at an advantage as they have a greater awareness of the need to make adjustments in school discourse compared to monolingual children, who may have no such awareness. While Mary Morrison and Perminder Sandhu in 'Towards a Multilingual Pedagogy' show that schools that support bilingual children's use of their mother tongue together with the mainstream language (English) tend to have children who are able to engage in complex thought. Cazden (2001, p. 56) concludes that

...the new importance of discourse in school-improvement efforts comes not from any anticipated substitution of non-traditional for traditional lessons, but from the need for teachers to have a repertoire of lesson structures and teaching styles, and the understanding of when one or another will be most appropriate

for an increasingly complex set of educational objectives.

Differential Treatment

Differential treatment is another area in which contemporary classrooms differ from the traditional classroom. According to Cazden (1992, 2001), given the potential classroom discourse has for students whereby it is significant for students to speak more and participate in a variety of contexts, teachers need to pay careful attention to who gets more opportunity to talk in class and who gets proper feedback. She provides several examples of research done on differential treatment and cultural differences, and how these together have an impact on learning.

Firstly, Cazden (2001) mentions James Collins, a linguist who analysed fragments of lessons where low-group and high-group children read stories of equal level of difficulty. He found that the teacher helped the two groups of students in contrasting ways: the high-group was assisted for meaning or understanding while the low-group was helped with word-calling or pronunciation. Secondly, Cazden (2001) describes classroom discourse, "... as the drama of teaching and learning with speaking parts for all" (p. 164). She talks about equality for speech and the important role of teachers of engaging all students in classroom interaction.

Other studies in the area of differential treatment include Fischer and Rose (2001), Juel and Cupp (2000), Mulroy and Eddinger (2003) and Tomlinson (2005).

Juel and Cupp (2000), mention that there is research evidence that temporary and partial differential treatment can improve the learning and relative achievement status of initially low-achieving children. Clay (2000) states, "Consequently, teachers plan for all children to have the same amount of exposure to each activity though actually individual learners need differential exposure" (p. 22).

CONCLUSION

This paper has outlined and critiqued key theorists and research that has informed and positioned part of the study reported within this paper. The various sections within this paper have served to stress not only the importance of classroom discourse but also the manner in which classroom talk could be made relevant to maximise learning benefits. There is sufficient literature to prove that making changes to aspects of classroom discourse such as making classroom talk more dialogic, organising time for talk and peer listening, teacher's revoicing, questioning techniques, waiting time, assigning intellectual roles and employing differential treatment is beneficial for learning. These are the features that differentiate a non-traditional classroom from a traditional one.

The entire discussion in this paper revolves around how classroom discourse can be turned into a relevant learning tool and is summarised into episodes. A summary of these episodes that promote learning within the classroom as identified by key researchers in classroom discourse

is given in the table below (Table 1). These episodes, if replicated in the classroom, have the potential to elicit learning benefits as depicted in many research studies. These will next be used to create a framework of analysis to act as a lens with which to view data gathered in a Malaysian undergraduate classroom; the data will be shared in the next and final paper in this series.

REFERENCES

- Alexander, R. (2006). *Education as dialogue - Moral and pedagogical choices for a runaway world*. Tai Po, Hong Kong: The Hong Kong Institute of Education.
- Alexander, R. (2012a). *Improving oracy and classroom talk in English schools: Achievements and challenges*, http://www.primaryreview.org.uk/downloads/_news/2012/02/2012_02_20DfE_oracy_Alexander.pdf (accessed 12.2.2014).
- Alexander, R. (2012b). Moral panic, miracle cures and educational policy: What can we really learn from international comparison? *Scottish Educational Review* 44 (1), 4-21.
- Bakhtin, M. (1986). *Speech genres and other late essays*. Austin, Texas: University of Texas Press.
- Barnes, D. (1992). The role of talk in learning. In K. Norman (Ed.), *Thinking voices: The work of the National Oracy Project*. London, England: Hodder & Stoughton.
- Bruer, J. T. (1994). *Schools for thought: A science of learning in the classroom*. Cambridge, MASS: The MIT Press.
- Cazden, C. B. (2001). *Classroom discourse - The language of teaching and learning* (2nd Edition ed.). Portsmouth, NH: Heinemann.
- Clay, M. M. (1997). International perspectives on the reading recovery program. In J. Flood, Heath, S. B. & Lapp, D. (Ed.), *Handbook of research on teaching literacy through the communicative and visual arts* (pp. 655 - 667). New York, NY: Macmillan.
- Deakin, C. (2005). *The research evidence of the impact on students of self and peer-assessment. Review conducted by the Assessment Review Group*. The EPPI –Centre, Inst of Education, Univ of London.
- Delpit, L. (1995). *Other people's children: Cultural conflict in the classroom*. New York, NY: New Press.
- Duckworth, E. (1981). *Understanding children's understandings*. Paper presented at the Ontario Institute for Studies in Education, Toronto, Canada.
- Fischer, K. W., & Rose, L. T. (2001). Webs of skill: How students learn. *Educational Leadership*, 59(3), 6-123.
- Halliday, M. A. K. (1993). Towards a language-based theory of learning. *Linguistics and Education*, 5, 93-116.
- Hashweh, M. Z. (2005.). Teacher pedagogical constructions: A reconfiguration of pedagogical content knowledge. *Teachers and Teaching: Theory and Practice*, 11(3), 273-292.
- Hill, H., Ball, D. L., & Schilling, S. (2008). "Unpacking 'pedagogical content knowledge': Conceptualizing and measuring teachers' topic-specific knowledge of students". *Journal for Research in Mathematics Education*, 39, 372-400.
- Hillocks, G. (1995). *Teaching writing as reflective practice*. New York, NY: Teachers College Press.
- Juel, C., & Cupp, M. (2000). Learning to read words: Linguistic units and instructional strategies. *Reading Research Quarterly*, 35, 458 - 493.
- Loughran, J., Berry, A., & Mulhall, P. (2006). *Understanding and developing science teachers' pedagogical content knowledge*. Rotterdam, The Netherlands: Sense Publishers.

- Loughran, J., Mulhall, P., & Berry, A. (2008). Exploring pedagogical content knowledge in Science teacher education: A case study. *International Journal of Science Education, Guest edited Special Issue, 30*(10), 1301-1320.
- Maybin, J., Mercer, N. & Stierer, B. (1992). 'Scaffolding' learning in the classroom. In K. Norman (Ed.), *Thinking voices* (pp. 186 - 195). London, England: Hodder & Stoughton.
- Mercer, N. (1992). Talk for teaching-and-learning. In K. Norman (Ed.), *Thinking voices: The work of the National Oracy Project*. London, England: Hodder & Stoughton.
- Mercer, N. (2000). *Words and minds - How we use language to think together*. London and New York: Routledge.
- Mercer, N. (2009). Developing argumentation: Lessons learned in the primary school. In N. Muller Mirza & A. N. Perret-Clermont (Eds.), *Argumentation and education: theoretical foundations and practices*. (pp.177-194). New York, NY: Springer DOI: 10. 1007/978-0-387-98125-3_7.
- Mercer, N. & Littleton, K. (2007). Dialogue and the development of children's thinking: A sociocultural approach. New York, NY: Routledge.
- Mulroy, H. & Eddinger, K. (2003). *Differentiation and literacy*. Institute on Inclusive Education, Nazareth College of Rochester. <http://www.pub.naz.edu:9000/~include/pdfs/poster/...> (accessed 27/6/2012).
- Norman, K. (Ed.). (1992). *Thinking voices: The work of the National Oracy Project*. London, England: Hodder & Stoughton.
- Nystrand, M., Gamoran, A., Kachur, R. & Prendergast, C. (1997). *Opening dialogue: Understanding the dynamics of language and learning in the English classroom*. New York, NY: Teachers College Press.
- O'Connor & Michaels, S. (1996). Shifting participant frameworks: Orchestrating thinking practices in group discussion. In D. Hicks (Ed.), *Discourse, learning and schooling* (pp. 63 -103). New York, NY: Cambridge University Press.
- Palincsar, A. S. (1996). Language-Minority students: Instructional issues in school cultures and classroom social systems. *The Elementary School Journal, 96*(3), 221 – 226.
- Rowe, M. B. (1986). Wait time: Slowing down may be a way of speeding up! *Journal of Teacher Education, 37*, 43 - 50.
- Schifter, D. (1997). Learning mathematics for teaching: Lessons in/from the domain of fractions. Newton, MA: Newton, MA: Education Development Centre, Center for the Development of Teaching. Paper Series.
- Sheeran, Y., & Barnes, D. (1991). *School writing*. Bristol, PA: Open University Press.
- Shulman, L. (1987). Knowledge and teaching: Foundations of the new reform. *Harvard Educational Review, 57*(1), 1 - 22.
- Snow, C. E., Burns, S. B., & Griffin, P. (Eds.). (1998). *Preventing reading difficulty in young children*. Washington, DC: National Academy Press.
- Tomlinson, C. (2005). Quality curriculum and instruction for highly able students. *Theory into Practice, 44*(2), 160 – 166.
- Tharp, R. G., & Gallimore, R. (1988). *Rousing minds to life: Teaching learning and schooling in social context*. Cambridge: Cambridge University Press.
- Vygotsky, L. S. (1978). *Mind in society*. Cambridge: Harvard University Press.
- Wake, B. J. (2006). Dialogic learning in tutorial talk: A case study of semiotic mediation as a learning resource for second language international students (Unpublished PhD thesis, The University of Adelaide, Australia). Retrieved from <http://hdl.handle.net/2440/40128>

Wegerif, R., Dawes, L. (2004). Developing thinking and learning with ICT: Raising achievement in primary classrooms Retrieved from UniM INTERNET resource database.

Wells, G. (1992). The centrality of talk in education. In K. Norman (Ed.), *Thinking voices: The work of the National Oracy Project*. London, England: Hodder & Stoughton.

TABLE 1
 Summary of Episodes in the Classroom that Help Enhance Learning as Recommended by Research

	Summary of episodes in the classroom that help enhance learning as recommended by research	Comments	Source
1.	Teacher explains the ground rules of oral and written communication in which formal language is used		Cazden, 2001
2.	Teacher is welcoming, respectful of all students and upholds equal status for all		Cazden, 2001; Barnes, 1992
3.	Teacher is open to unconventional methods of sharing		Cazden, 2001
4.	Teacher accepts alternative answers by students but encourages comparisons and justification		Cazden, 2001
5.	Teacher talk is reduced while students' response time is extended	In the traditional classroom, the teacher normally talks for two thirds of the class time but this is now reduced	Cazden, 2001
6.	Teacher needs to have good "pedagogical content knowledge"	This is important for teachers to understand student understanding of the lesson	Cazden, 2001; Mercer, 1992
7.	Scaffolds - examples of episodes for a writing class		Adapted from Hillocks, 1995, 178-179
	1. <i>Initial writing samples.</i> Write about an experience that is important to you for some reason...		
	2. <i>Examples of personal narrative.</i> Students read and talk about examples by professionals and other students...		
	3. <i>Idea sheets.</i> After receiving a sample from the teacher, students work individually, writing a few sentences about their own experiences [that they might write about]...		
	4. <i>Introduction to using specific detail.</i> Describing shells in teacher-led lesson, small groups and individually with feedback episodes [and revision demonstrated and tried]		
	5. <i>Details about people and places.</i> Teacher-led talk about an interesting drawing or photograph, followed by small-group work which is then read aloud and a workshop with individuals working on idea sheets, reading aloud, then feedback and revision		
	6. <i>Describing sounds.</i> Teacher-led talk about recording of various sounds		
	7. <i>Writing about bodily sensations.</i> Various in-class exercises followed by writing about a strenuous activity from one's own experience		
	8. <i>Writing about the "dumpster scenario."</i> Students asked to make an imaginative leap into a teacher-given scenario, then to write individually, with teacher coaching followed by reading in small groups, feedback and revision.		

TABLE 1 (continue)

Summary of episodes in the classroom that help enhance learning as recommended by research	Comments	Source
<p>9. <i>Pantomime of characters in emotional states.</i> Volunteer acts out teacher-given pantomime, then students work in small groups with one student acting and others writing details for an audience who did not see the actor.</p>		
<p>10. <i>Invention of dialogue.</i> Read and discuss examples as in #2; teacher-led development of dialogue (in play form) based on one scenario, followed by small-group work on another scenario; students present and then receive feedback.</p>		
<p>11. <i>Individual work on dialogue from idea sheet scenario.</i> Read aloud, feedback and revision</p>		
<p>12. <i>Punctuation of dialogue.</i> Teacher demonstrates; groups punctuate dialogue already written out – if successful, individuals convert dialogue from #11 to prose form and edit each other’s punctuation</p>		
<p>13. <i>Workshop.</i> Students select an incident from idea sheets – drafting, periodic reading in small groups for feedback, revision, using a check-list, prompt ideas for revision</p>		
<p>14. <i>Class publication.</i> Students choose which to include, with all students represented if possible</p>		
<p>15. <i>Final writing sample</i> comparable to #1.</p>		
<p>8. Types of discourse emphasised by the discourse-intensive reform programme class</p>		Adapted from Bruer, 1994, 286-289)
<p>i. Social interaction...allows skilled thinkers to demonstrate expert strategies to the naive...[It] makes hidden thought processes public and shared...</p>		
<p>ii. Communal interactions allow students to share and distribute the cognitive burdens of thinking. A group provides a more information-rich context for learning...There are greater varieties of cues to trigger recall of information from individual memories...</p>		
<p>iii. Dialogue requires both language comprehension and language production. Because production is cognitively more demanding, dialogue might then result in deeper processing of information.</p>		
<p>iv. Social settings send message that thinking and intelligence are socially valued</p>		
<p>v. Thought, learning and knowledge are not just influenced by social factors, but are irreducibly social phenomena. Discourse does not make thought visible, rather thought is internalised discourse.</p>		
<p>9. Teacher and students establish mutual trust</p>		Cazden, 2001
<p>10. Teacher organises opportunities to talk</p>		Cazden, 2001; Tharp & Gallimore, 1988
<p>1. There are many ways to organise opportunities to speak:</p>		
<p>2. “Deregulating” classroom discourse – may result in inequality, this could be addressed by teacher nomination according to seating positions</p>		
<p>3. Encouraging “handing off”- allow students to select the next speaker</p>		
<p>4. Use of “Talking stick” – student who receives the stick gets the opportunity to speak which he/she can choose to utilise the opportunity or pass it on</p>		
<p>5. Requiring all students to take a stance on an issue</p>		

TABLE 1 (continue)

Summary of episodes in the classroom that help enhance learning as recommended by research	Comments	Source
11. Teacher listens carefully and makes peer listening happen	Learning takes place while discussing problems in groups compared to working individually	Cazden, 2001 Alexander, 2006, 2012b
12. Teacher's revoicing By repeating students' ideas to the class, the teacher actually summarises and reformulates the points uttered by students Reconceptualisation – "a fusing of the teacher's words, register or knowledge with the original intent of the student." (pg 81) Revoicing is essential for constructing common knowledge and building a community of learners, and is gaining in popularity		O'Connor & Michaels 1996
13. Teacher asks questions for the purpose for assisting and assessing students		
14. Tea Teacher's responses – fewer mistakes in discourse and smoother building up of ideas Teacher's questions – fewer but higher level cognitively Teacher's use of students' opinions is enhanced More students, particularly those who were silent, participate in the discussion Less demand on the students to perform all the four moves – e.g. preparing to solicit ideas, airing those ideas and being answerable to the teacher for the idea given e.g. justify, defend etc.		Rowe, 1986
15. Enable students to assume various intellectual roles i. Spontaneously helping each other – e.g. when a fifth grader in a central Los Angeles school was required to record words and illustrations that depicted the desert (after a class trip), she asked peers for help in remembering a word. The "socially shared cognition" with peers helped them to use one another's memories as word search resources. This in turn enabled the student to succeed in her word search. ii. Tutoring another student when assigned to by the teacher – the initial awareness of the responsibility of having to teach others later leads students to take their own learning seriously. This helps 'tutors' find a new dignity in seeing themselves as experts and resource persons, even as their teachers observe an increase in their keenness to participate in the class as well as to assume lead roles. It is a good opportunity for students to give directions instead of receiving them and to ask questions instead of having to answer them. Teachers also could rely on these observations to pitch their expectations of their students. iii. Reciprocally providing "critique" of each other's work (as in peer writing conferences) – a critique differs from criticism in that it is about work still in progress given by a colleague to another and is reciprocal, while criticism is given by professionals on completed work and is one way. iv. Collaborating as presumed equal-status learners on assigned tasks – Webb and Palincsar (1996, pg. 867), "The long list of group and classroom features provides a menu of possible ways to enhance the quality of collaboration in the classroom."		Alexander, 2006, 2012b

TABLE 1 (continue)

	Summary of episodes in the classroom that help enhance learning as recommended by research	Comments	Source
16.	Teacher plans differential exposure for individual learners		Adapted from Clay, 2000, 22 Adapter from Mercer, 1992
17.	Teacher pays attention to the following to alleviate reading problems among young readers - “ <i>distinguish between mistakes in reading and mistakes in pronunciation</i> ” - “ <i>give more attention to the ends of words</i> ” (where variation in pronunciation is more apparent)		William Labov cited in Snow et al., 1998, 241-42
18.	Teacher explains reasons why learners should be involved in various types of conversation and the usefulness of conversation	Language taught within context is better learnt compared to language learnt out of context	Barnes, 1992; Mercer, 1992
19.	Effort to engage students’ minds and thinking to - question, listen, reflect, reason, explain, speculate and explore ideas - analyse problems, frame hypotheses and develop solutions - discuss, argue, examine evidence, defend, probe and assess arguments - see through the rhetorical games that people play in order to disguise their real intentions or deny access to the truth	Dialogic pedagogy is claimed to be an essential underlying infrastructure for successful learning as well as good society and future citizens	Adapted from Alexander, 2006, 2012b 2005 EPI review cited in Deakin Crick et al., 2005
20.	Teacher asks authentic questions to encourage students to think for themselves and to ask questions	Promotes equality in the classroom and encourages students to ask genuine questions	Cazden, 2001 Alexander, 2006, 2012b Nystrom et al., 1997
21.	Teacher provides feedback/answers to students’ answers/questions that provokes further thinking and questioning		Alexander, 2006, 2012 Bakhtin, 1986

APPENDIX 1
FRAMEWORK DEVELOPED FROM PZ RESEARCH

No	Episodes to look out for in the classroom	Comments
1	<p>Questions thrown out to class seeking interpretation and justification <i>(See/Think/Wonder – Core Routine, similar to What makes you say that- UR)</i></p> <ul style="list-style-type: none"> - What do you see? What's going on? - What does it make you think/ feel? - What makes you say that? - What does it make you wonder? 	<p>This routine helps students describe what they see or know and build explanations, promotes evidential reasoning and encourages students to understand alternatives and multiple perspectives. Initially, teacher needs to scaffold students by continuously asking follow-up questions; over time they will automatically support their interpretations with evidence.</p>
2	<p>Effort to link students' prior knowledge to the lesson (<i>Connect extend challenge- UR/ 3-2-1 Bridge-UR</i>)</p> <ul style="list-style-type: none"> • How are the ideas and information presented connected to what you already know? • What new ideas did you get that extended or pushed your thinking in new directions? • What is still challenging or confusing for you to get your mind around? • What questions, wonderings or puzzles do you now have? • Students respond either in writing or verbally to 'I used to think ...' • Students respond either in writing or verbally to 'Now I think ...' 	<p>Works well with whole class, in small groups or individually; students share some of their thoughts and collect a list of ideas in each of the three categories, or write their individual responses to add to class chart – keep students' thinking alive over time, continue to add new ideas to the lists and revisit the ideas and questions on the chart as students' understanding around the topic develops.</p>
3	<p>Effort to enable students to capture essence of an issue and present it in verbal or non-verbal ways (<i>Headlines- UR</i>)</p> <p>If you were asked to give a headline for this topic or issue right now that captured the most important aspect that should be remembered, what would that headline be?</p> <ul style="list-style-type: none"> • How has your headline changed based on today's discussion? • How does it differ from what you would have said yesterday? 	

APPENDIX 2
TEMPLATE FOR CATEGORIES/DESCRIPTORS DERIVED FROM ‘VISIBLE THINKING’ AND CLASSROOM INTERACTION RESEARCH

Categories/descriptors derived from ‘Visible thinking’ and classroom interaction research (My organisation)	What visible thinking researchers have observed as manifestations	Manifestations within Malaysian context outlined in this research
<p>A. Classroom organisation/environment (incorporates VT routines/physical environment):</p> <ul style="list-style-type: none"> • Teacher characteristics - Teacher PCK • Routines - Procedures • Physical environment • Relationship dimensions • Trust/ Promotion of risk taking (ideas, questions) • Teacher-centred time/student-centred time 		
<p>B. Relationship/classroom climate (incorporates VT relationship):</p>		
<p>C. Curriculum linking, transparency of intentions and promotion of metacognitive dimensions (incorporates VT modelling, expectations):</p> <ul style="list-style-type: none"> • Clarity of task, priorities and intention • Personalising learning/differentiation • Exploring prior knowledge and understandings • Student involvement • Goal setting • Decision making • Reasoning 		



**REFEREES FOR THE PERTANIKA
JOURNAL OF SOCIAL SCIENCES AND HUMANITIES**

VOL. 22(3) SEPT. 2014

The Editorial Board of the Journal of Social Sciences and Humanities wishes to thank the following:

Abdul Latif Abd Razak
(IIUM, Malaysia)

Aida Suraya Md Yunus
(UPM, Malaysia)

Ali Salman
(UKM, Malaysia)

Allan White
*(University of Western Sydney (UWS),
Australia)*

Anne Althea Christopher
(UUM, Malaysia)

Aznan Che Ahmad
(USM, Malaysia)

Azrina Husin
(USM, Malaysia)

Balakrishnan Muniandy
(USM, Malaysia)

Cecilia Cheong Yin Mei
(UM, Malaysia)

Cheng Fan Fah
(UPM, Malaysia)

Elena Gregoria Chai Chin Fern
(UNIMAS, Malaysia)

Ena Bhattacharyya
(UTP, Malaysia)

Fazal Mohamed Mohamed
Sultan
(UKM, Bangi)

Ghayth K. Shaker Al- Shaibani
(USM, Malaysia)

Graham Thurgood
(California State University, USA)

Habibah Elias
(UPM, Malaysia)

Hasrina Mustafa
(USM, Malaysia)

Hrushkesh Senapaty
*(The National Council of Educational
Research and Training (NCERT), India)*

Jamaliah Abdul Hamid
(UPM, Malaysia)

Jariah Mohd Jan
(UM, Malaysia)

Jayakaran Mukundan
(UPM, Malaysia)

Jennifer Tunga Janang
(UiTM, Malaysia)

Kiranjeet Kaur Dhillon
(UiTM, Malaysia)

Lilly Metom
(UiTM, Malaysia)

Mary Susan Philip
(UM, Malaysia)

Ng Kui Choo
(UiTM, Malaysia)

Nik Rosila Nik Yaacob
(USM, Malaysia)

Norasimah Othman
(UKM, Malaysia)

Rodney C. Jubilado
(Univeristy of Hawaii, USA)

Sailesh Sharma
(UM, Malaysia)

Sarjit Kaur Gurdial Singh
(USM, Malaysia)

Shakila Abd. Manan
(USM, Malaysia)

Sheeba J. Irwin
(Madras Christian College, India)

Stephen Azariah
(RKM Vivekananda College, India)

Stephen Hall
(Sunway University College, Malaysia)

Teh Chee Seng
@ Elvis Teh Chee Seng
(UTAR, Malaysia)

Teoh Sian Hoon
(UiTM, Malaysia)

Turiman Suandi
(UPM, Malaysia)

Vilma Singh
(Punjab University, India)

Zainudin Mohd Isa
(USM, Malaysia)

UPM - Universiti Putra Malaysia

UM - Universiti Malaya

UiTM - Universiti Teknologi MARA

USM - Universiti Sains Malaysia

UKM - Universiti Kebangsaan Malaysia

UTP - Universiti Teknologi PETRONAS

UUM - Universiti Utara Malaysia

UTAR - Universiti Tun Abdul Razak

UNIMAS - Universiti Malaysia Sarawak

IIUM - International Islamic University Malaysia

While every effort has been made to include a complete list of referees for the period stated above, however if any name(s) have been omitted unintentionally or spelt incorrectly, please notify the Chief Executive Editor, *Pertanika* Journals at nayan@upm.my.

Any inclusion or exclusion of name(s) on this page does not commit the *Pertanika* Editorial Office, nor the UPM Press or the University to provide any liability for whatsoever reason.



Pertanika

Our goal is to bring high quality research to the widest possible audience

Journal of Social Sciences and Humanities

INSTRUCTIONS TO AUTHORS (Manuscript Preparation & Submission Guidelines)

Revised: June 2014

*We aim for excellence, sustained by a responsible and professional approach to journal publishing.
We value and support our authors in the research community.*

Please read the guidelines and follow these instructions carefully; doing so will ensure that the publication of your manuscript is as rapid and efficient as possible. The Editorial Board reserves the right to return manuscripts that are not prepared in accordance with these guidelines.

About the Journal

Pertanika is an international peer-reviewed journal devoted to the publication of original papers, and it serves as a forum for practical approaches to improving quality in issues pertaining to tropical agriculture and its related fields. *Pertanika* began publication in 1978 as Journal of Tropical Agricultural Science. In 1992, a decision was made to streamline *Pertanika* into three journals to meet the need for specialised journals in areas of study aligned with the interdisciplinary strengths of the university. The revamped Journal of Social Sciences & Humanities (JSSH) aims to develop as a pioneer journal for the Social Sciences with a focus on emerging issues pertaining to the social and behavioural sciences as well as the humanities, particularly in the Asia Pacific region. Other *Pertanika* series include Journal of Tropical Agricultural Science (JTAS); and Journal of Science and Technology (JST).

JSSH is published in **English** and it is open to authors around the world regardless of the nationality. It is currently published four times a year i.e. in **March, June, September** and **December**.

Goal of *Pertanika*

Our goal is to bring the highest quality research to the widest possible audience.

Quality

We aim for excellence, sustained by a responsible and professional approach to journal publishing. Submissions are guaranteed to receive a decision within 12 weeks. The elapsed time from submission to publication for the articles averages 5-6 months.

Indexing of *Pertanika*

Pertanika is now over 33 years old; this accumulated knowledge has resulted in *Pertanika* JSSH being indexed in SCOPUS (Elsevier), EBSCO, Thomson (ISI) Web of Knowledge [CAB Abstracts], DOAJ, Google Scholar, ISC and MyAIS.

Future vision

We are continuously improving access to our journal archives, content, and research services. We have the drive to realise exciting new horizons that will benefit not only the academic community, but society itself.

We also have views on the future of our journals. The emergence of the online medium as the predominant vehicle for the 'consumption' and distribution of much academic research will be the ultimate instrument in the dissemination of research news to our scientists and readers.

Aims and scope

Pertanika Journal of Social Sciences & Humanities aims to develop as a pioneer journal for the social sciences with a focus on emerging issues pertaining to the social and behavioural sciences as well as the humanities. Areas relevant to the scope of the journal include Social Sciences—Accounting, anthropology, Archaeology and history, Architecture and habitat, Consumer and family economics, Economics, Education, Finance, Geography, Law, Management studies, Media and communication studies, Political sciences and public policy, Population studies, Psychology, Sociology, Technology management, Tourism; Humanities—Arts and culture, Dance, Historical and civilisation studies, Language and Linguistics, Literature, Music, Philosophy, Religious studies, Sports.

Editorial Statement

Pertanika is the official journal of Universiti Putra Malaysia. The abbreviation for *Pertanika* Journal of Social Sciences & Humanities is *Pertanika J. Soc. Sci. Hum.*

Guidelines for Authors

Publication policies

Pertanika policy prohibits an author from submitting the same manuscript for concurrent consideration by two or more publications. It prohibits as well publication of any manuscript that has already been published either in whole or substantial part elsewhere. It also does not permit publication of manuscript that has been published in full in Proceedings. Please refer to *Pertanika*'s **Code of Ethics** for full details.

Editorial process

Authors are notified on receipt of a manuscript and upon the editorial decision regarding publication.

Manuscript review: Manuscripts deemed suitable for publication are sent to the Editorial Board members and/or other reviewers. We encourage authors to suggest the names of possible reviewers. Notification of the editorial decision is usually provided within to eight to ten weeks from the receipt of manuscript. Publication of solicited manuscripts is not guaranteed. In most cases, manuscripts are accepted conditionally, pending an author's revision of the material.

Author approval: Authors are responsible for all statements in articles, including changes made by editors. The liaison author must be available for consultation with an editor of *The Journal* to answer questions during the editorial process and to approve the edited copy. Authors receive edited typescript (not galley proofs) for final approval. Changes **cannot** be made to the copy after the edited version has been approved.

Manuscript preparation

Pertanika accepts submission of mainly four types of manuscripts. Each manuscript is classified as **regular** or **original** articles, **short communications**, **reviews**, and proposals for **special issues**. Articles must be in **English** and they must be competently written and argued in clear and concise grammatical English. Acceptable English usage and syntax are expected. Do not use slang, jargon, or obscure abbreviations or phrasing. Metric measurement is preferred; equivalent English measurement may be included in parentheses. Always provide the complete form of an acronym/abbreviation the first time it is presented in the text. Contributors are strongly recommended to have the manuscript checked by a colleague with ample experience in writing English manuscripts or an English language editor.

Linguistically hopeless manuscripts will be rejected straightaway (e.g., when the language is so poor that one cannot be sure of what the authors really mean). This process, taken by authors before submission, will greatly facilitate reviewing, and thus publication if the content is acceptable.

The instructions for authors must be followed. Manuscripts not adhering to the instructions will be returned for revision without review. Authors should prepare manuscripts according to the guidelines of *Pertanika*.

1. Regular article

Definition: Full-length original empirical investigations, consisting of introduction, materials and methods, results and discussion, conclusions. Original work must provide references and an explanation on research findings that contain new and significant findings.

Size: Should not exceed 5000 words or 8-10 printed pages (excluding the abstract, references, tables and/or figures). One printed page is roughly equivalent to 3 type-written pages.

2. Short communications

Definition: Significant new information to readers of the Journal in a short but complete form. It is suitable for the publication of technical advance, bioinformatics or insightful findings of plant and animal development and function.

Size: Should not exceed 2000 words or 4 printed pages, is intended for rapid publication. They are not intended for publishing preliminary results or to be a reduced version of Regular Papers or Rapid Papers.

3. Review article

Definition: Critical evaluation of materials about current research that had already been published by organizing, integrating, and evaluating previously published materials. Re-analyses as meta-analysis and systemic reviews are encouraged. Review articles should aim to provide systemic overviews, evaluations and interpretations of research in a given field.

Size: Should not exceed 4000 words or 7-8 printed pages.

4. Special issues

Definition: Usually papers from research presented at a conference, seminar, congress or a symposium.

Size: Should not exceed 5000 words or 8-10 printed pages.

5. Others

Definition: Brief reports, case studies, comments, Letters to the Editor, and replies on previously published articles may be considered.

Size: Should not exceed 2000 words or up to 4 printed pages.

With few exceptions, original manuscripts should not exceed the recommended length of 6 printed pages (about 18 typed pages, double-spaced and in 12-point font, tables and figures included). Printing is expensive, and, for the Journal, postage doubles when an issue exceeds 80 pages. You can understand then that there is little room for flexibility.

Long articles reduce the Journal's possibility to accept other high-quality contributions because of its 80-page restriction. We would like to publish as many good studies as possible, not only a few lengthy ones. (And, who reads overly long articles anyway?) Therefore, in our competition, short and concise manuscripts have a definite advantage.

Format

The paper should be formatted in one column format with at least 4cm margins and 1.5 line spacing throughout. Authors are advised to use Times New Roman 12-point font. Be especially careful when you are inserting special characters, as those inserted in different fonts may be replaced by different characters when converted to PDF files. It is well known that 'µ' will be replaced by other characters when fonts such as 'Symbol' or 'Mincho' are used.

A maximum of eight keywords should be indicated below the abstract to describe the contents of the manuscript. Leave a blank line between each paragraph and between each entry in the list of bibliographic references. Tables should preferably be placed in the same electronic file as the text. Authors should consult a recent issue of the Journal for table layout.

Every page of the manuscript, including the title page, references, tables, etc. should be numbered. However, no reference should be made to page numbers in the text; if necessary, one may refer to sections. Underline words that should be in italics, and do not underline any other words.

We recommend that authors prepare the text as a **Microsoft Word** file.

1. Manuscripts in general should be organised in the following order:

- **Page 1: Running title.** (Not to exceed 60 characters, counting letters and spaces). This page should **only** contain the running title of your paper. The running title is an abbreviated title used as the running head on every page of the manuscript.

In addition, the **Subject areas** most relevant to the study must be indicated on this page. Select the appropriate subject areas from the Scope of the Journals provided in the Manuscript Submission Guide.

- A **list of number of black and white / colour figures and tables** should also be indicated on this page. Figures submitted in color will be printed in colour. See "5. Figures & Photographs" for details.
- **Page 2: Author(s) and Corresponding author information.** This page should contain the **full title** of your paper with name(s) of all the authors, institutions and corresponding author's name, institution and full address (Street address, telephone number (including extension), hand phone number, fax number and e-mail address) for editorial correspondence. The names of the authors **must** be abbreviated following the international naming convention. e.g. Salleh, A.B., Tan, S.G., or Sapuan, S.M.

Authors' addresses. Multiple authors with different addresses must indicate their respective addresses separately by superscript numbers:

George Swan¹ and Nayan Kanwal²

¹Department of Biology, Faculty of Science, Duke University, Durham, North Carolina, USA.

²Office of the Deputy Vice Chancellor (R&I), Universiti Putra Malaysia, Serdang, Malaysia.

- **Page 3:** This page should **repeat** the **full title** of your paper with only the **Abstract** (the abstract should be less than 250 words for a Regular Paper and up to 100 words for a Short Communication). **Keywords** must also be provided on this page (Not more than eight keywords in alphabetical order).
- **Page 4 and subsequent pages:** This page should begin with the **Introduction** of your article and the rest of your paper should follow from page 5 onwards.

Abbreviations. Define alphabetically, other than abbreviations that can be used without definition. Words or phrases that are abbreviated in the introduction and following text should be written out in full the first time that they appear in the text, with each abbreviated form in parenthesis. Include the common name or scientific name, or both, of animal and plant materials.

Footnotes. Current addresses of authors if different from heading.

2. **Text.** Regular Papers should be prepared with the headings **Introduction, Materials and Methods, Results and Discussion, Conclusions** in this order. Short Communications should be prepared according to "8. *Short Communications.*" below.
3. **Tables.** All tables should be prepared in a form consistent with recent issues of *Pertanika* and should be numbered consecutively with Arabic numerals. Explanatory material should be given in the table legends and footnotes. Each table should be prepared on a separate page. (Note that when a manuscript is accepted for publication, tables must be submitted as data - .doc, .rtf, Excel or PowerPoint file- because tables submitted as image data cannot be edited for publication.)
4. **Equations and Formulae.** These must be set up clearly and should be typed triple spaced. Numbers identifying equations should be in square brackets and placed on the right margin of the text.
5. **Figures & Photographs.** Submit an original figure or photograph. Line drawings must be clear, with high black and white contrast. Each figure or photograph should be prepared on a separate sheet and numbered consecutively with Arabic numerals. Appropriate sized numbers, letters and symbols should be used, no smaller than 2 mm in size after reduction to single column width (85 mm), 1.5-column width (120 mm) or full 2-column width (175 mm). Failure to comply with these specifications will require new figures and delay in publication. For electronic figures, create your figures using applications that are capable of preparing high resolution TIFF files acceptable for publication. In general, we require **300 dpi or higher resolution for coloured and half-tone artwork** and **1200 dpi or higher for line drawings**.

For review, you may attach low-resolution figures, which are still clear enough for reviewing, to keep the file of the manuscript under 5 MB. Illustrations may be produced at extra cost in colour at the discretion of the Publisher; the author could be charged Malaysian Ringgit 50 for each colour page.

6. **References.** Literature citations in the text should be made by name(s) of author(s) and year. For references with more than two authors, the name of the first author followed by 'et al.' should be used.

Swan and Kanwal (2007) reported that ...

The results have been interpreted (Kanwal *et al.*, 2009).

- References should be listed in alphabetical order, by the authors' last names. For the same author, or for the same set of authors, references should be arranged chronologically. If there is more than one publication in the same year for the same author(s), the letters 'a', 'b', etc., should be added to the year.
- When the authors are more than 11, list 5 authors and then et al.
- Do not use indentations in typing References. Use one line of space to separate each reference. The name of the journal should be written in full. For example:
 - Mellers, B. A. (2006a). Choice and the relative pleasure of consequences. *Psychological Bulletin*, 126, 910-924.
 - Mellers, B. A. (2006b). Treatment for sexually abused children and adolescents. *American Psychologist*, 55, 1040-1049.
 - Hawe, P. (2005). Capturing the meaning of "community" in community intervention evaluation: Some contributions from community psychology. *Health Promotion International*, 9, 199-210.
 - Braconier, H., & Ekholm, K. (2006). Swedish multinationals and competition from high and low wage location. *Review of International Economics*, 8, 448-461.
- In case of citing an author(s) who has published more than one paper in the same year, the papers should be distinguished by addition of a small letter as shown above, e.g. Jalaludin (1997a); Jalaludin (1997b).
- Unpublished data and personal communications should not be cited as literature citations, but given in the text in parentheses. 'In press' articles that have been accepted for publication may be cited in References. Include in the citation the journal in which the 'in press' article will appear and the publication date, if a date is available.

7. **Examples of other reference citations:**

Monographs: Kalimapur, Y.R. (2004). *Images of the U.S. Around the World: A Multicultural Perspective*. Albany, NY: State University of New York Press.

Chapter in Book: Bjork, R. A. (2007). Retrieval inhibition as an adaptive mechanism in human memory. In H. L. Roediger III & F. I. M. Craik (Eds.), *Varieties of memory & consciousness* (pp. 309-330). Hull: Hull University Press.

- **Proceedings:** Amir Awang. (2006). Counseling, human resources development and counseling services. In Sulaiman M. Yassin, Yahya Mat Hassan, Kamariah Abu Bakar, Esah Munji and Sabariah Mohd. Rashid (Eds.), *Proceedings of Asia Pacific Conference on Human Development* (p. 243-246). Serdang: Universiti Putra Malaysia.

8. **Short Communications** should include **Introduction, Materials and Methods, Results and Discussion, Conclusions** in this order. Headings should only be inserted for Materials and Methods. The abstract should be up to 100 words, as stated above. Short Communications must be 5 printed pages or less, including all references, figures and tables. References should be less than 30. A 5 page paper is usually approximately 3000 words plus four figures or tables (if each figure or table is less than 1/4 page).

*Authors should state the total number of words (including the Abstract) in the cover letter. Manuscripts that do not fulfill these criteria will be rejected as Short Communications without review.

STYLE OF THE MANUSCRIPT

Manuscripts should follow the style of the latest version of the Publication Manual of the American Psychological Association (APA). The journal uses American or British spelling and authors may follow the latest edition of the Oxford Advanced Learner's Dictionary for British spellings.

SUBMISSION OF MANUSCRIPTS

All articles should be submitted electronically using the ScholarOne web-based system. ScholarOne, a Thomson Reuters product provides comprehensive workflow management systems for scholarly journals. For more information, go to our web page and click "**Online Submission**".

Alternatively, you may submit the electronic files (cover letter, manuscript, and the **Manuscript Submission Kit** comprising *Declaration and Referral* form) via email directly to the Executive Editor. If the files are too large to email, mail a CD containing the files. The **Manuscript Submission Guide** and **Submission Kit** are available from the *Pertanika's* home page at <http://www.pertanika.upm.edu.my/home.php> or from the Chief Executive Editor's office upon request.

All articles submitted to the journal **must comply** with these instructions. Failure to do so will result in return of the manuscript and possible delay in publication.

Please do **not** submit manuscripts to the editor-in-chief or to any other office directly. All manuscripts must be **submitted through the chief executive editor's office** to be properly acknowledged and rapidly processed at the address below:

Dr. Nayan KANWAL
Chief Executive Editor
Pertanika Journals, UPM Press
Office of the Deputy Vice Chancellor (R&I)
IDEA Tower II, UPM-MTDC Technology Centre
Universiti Putra Malaysia
43400 UPM, Serdang, Selangor,
Malaysia

E-mail: nayan@upm.my; journal.officer@gmail.com tel: + 603-8947 1622
or visit our website at <http://www.pertanika.upm.edu.my/> for further information.

Authors should retain copies of submitted manuscripts and correspondence, as materials can not be returned. Authors are required to inform the Chief Executive Editor of any change of address which occurs whilst their papers are in the process of publication.

Cover letter

All submissions must be accompanied by a cover letter detailing what you are submitting. Papers are accepted for publication in the journal on the understanding that the article is original and the content has not been published or submitted for publication elsewhere. This must be stated in the cover letter.

The cover letter must also contain an acknowledgement that all authors have contributed significantly, and that all authors are in agreement with the content of the manuscript.

The cover letter of the paper should contain (i) the title; (ii) the full names of the authors; (iii) the addresses of the institutions at which the work was carried out together with (iv) the full postal and email address, plus facsimile and telephone numbers of the author to whom correspondence about the manuscript should be sent. The present address of any author, if different from that where the work was carried out, should be supplied in a footnote.

As articles are double-blind reviewed, material that might identify authorship of the paper should be placed on a cover sheet.

Peer review

Pertanika follows a **double-blind peer-review** process. Peer reviewers are experts chosen by journal editors to provide written assessment of the **strengths** and **weaknesses** of written research, with the aim of improving the reporting of research and identifying the most appropriate and highest quality material for the journal.

In the peer-review process, three referees independently evaluate the scientific quality of the submitted manuscripts. Authors are encouraged to indicate in the **Referral form** using the **Manuscript Submission Kit** the names of three potential reviewers, but the editors will make the final choice. The editors are not, however, bound by these suggestions..

Manuscripts should be written so that they are intelligible to the professional reader who is not a specialist in the particular field. They should be written in a clear, concise, direct style. Where contributions are judged as acceptable for publication on the basis of content, the Editor reserves the right to modify the typescripts to eliminate ambiguity and repetition, and improve communication between author and reader. If extensive alterations are required, the manuscript will be returned to the author for revision.

The Journal's review process

What happens to a manuscript once it is submitted to *Pertanika*? Typically, there are seven steps to the editorial review process:

1. The executive editor and the editorial board examine the paper to determine whether it is appropriate for the journal and should be reviewed. If not appropriate, the manuscript is rejected outright and the author is informed.
2. The executive editor sends the article-identifying information having been removed, to three reviewers. Typically, one of these is from the Journal's editorial board. Others are specialists in the subject matter represented by the article. The executive editor asks them to complete the review in three weeks and encloses two forms: (a) referral form B and (b) reviewer's comment form along with reviewer's guidelines. Comments to authors are about the appropriateness and adequacy of the theoretical or conceptual framework, literature review, method, results and discussion, and conclusions. Reviewers often include suggestions for strengthening of the manuscript. Comments to the editor are in the nature of the significance of the work and its potential contribution to the literature.
3. The executive editor, in consultation with the editor-in-chief, examines the reviews and decides whether to reject the manuscript, invite the author(s) to revise and resubmit the manuscript, or seek additional reviews. Final acceptance or rejection rests with the Editorial Board, who reserves the right to refuse any material for publication. In rare instances, the manuscript is accepted with almost no revision. Almost without exception, reviewers' comments (to the author) are forwarded to the author. If a revision is indicated, the editor provides guidelines for attending to the reviewers' suggestions and perhaps additional advice about revising the manuscript.
4. The authors decide whether and how to address the reviewers' comments and criticisms and the editor's concerns. The authors submit a revised version of the paper to the executive editor along with specific information describing how they have answered' the concerns of the reviewers and the editor.
5. The executive editor sends the revised paper out for review. Typically, at least one of the original reviewers will be asked to examine the article.
6. When the reviewers have completed their work, the executive editor in consultation with the editorial board and the editor-in-chief examine their comments and decide whether the paper is ready to be published, needs another round of revisions, or should be rejected.
7. If the decision is to accept, the paper is sent to that Press and the article should appear in print in approximately three months. The Publisher ensures that the paper adheres to the correct style (in-text citations, the reference list, and tables are typical areas of concern, clarity, and grammar). The authors are asked to respond to any queries by the Publisher. Following these corrections, page proofs are mailed to the corresponding authors for their final approval. At this point, only essential changes are accepted. Finally, the article appears in the pages of the Journal and is posted on-line.

English language editing

Pertanika **emphasizes** on the linguistic accuracy of every manuscript published. Thus all authors are required to get their manuscripts edited by **professional English language editors**. Author(s) **must provide a certificate** confirming that their manuscripts have been adequately edited. A proof from a recognised editing service should be submitted together with the cover letter at the time of submitting a manuscript to Pertanika. **All costs will be borne by the author(s)**.

This step, taken by authors before submission, will greatly facilitate reviewing, and thus publication if the content is acceptable.

Author material archive policy

Authors who require the return of any submitted material that is rejected for publication in the journal should indicate on the cover letter. If no indication is given, that author's material should be returned, the Editorial Office will dispose of all hardcopy and electronic material.

Copyright

Authors publishing the Journal will be asked to sign a declaration form. In signing the form, it is assumed that authors have obtained permission to use any copyrighted or previously published material. All authors must read and agree to the conditions outlined in the form, and must sign the form or agree that the corresponding author can sign on their behalf. Articles cannot be published until a signed form has been received.

Lag time

A decision on acceptance or rejection of a manuscript is reached in 3 to 4 months (average 14 weeks). The elapsed time from submission to publication for the articles averages 5-6 months.

Hardcopies of the Journals and off prints

Under the Journal's open access initiative, authors can choose to download free material (via PDF link) from any of the journal issues from Pertanika's website. Under "Browse Journals" you will see a link entitled "Current Issues" or "Archives". Here you will get access to all back-issues from 1978 onwards.

The **corresponding author** for all articles will receive one complimentary hardcopy of the journal in which his/her articles is published. In addition, 20 off prints of the full text of their article will also be provided. Additional copies of the journals may be purchased by writing to the executive editor.



Why should you publish in *Pertanika*?

BENEFITS TO AUTHORS

PROFILE: Our journals are circulated in large numbers all over Malaysia, and beyond in Southeast Asia. Our circulation covers other overseas countries as well. We ensure that your work reaches the widest possible audience in print and online, through our wide publicity campaigns held frequently, and through our constantly developing electronic initiatives such as Web of Science Author Connect backed by Thomson Reuters.

QUALITY: Our journals' reputation for quality is unsurpassed ensuring that the originality, authority and accuracy of your work is fully recognised. Each manuscript submitted to *Pertanika* undergoes a rigid originality check. Our double-blind peer refereeing procedures are fair and open, and we aim to help authors develop and improve their scientific work. *Pertanika* is now over 35 years old; this accumulated knowledge has resulted in our journals being indexed in SCOPUS (Elsevier), Thomson (ISI) Web of Knowledge [BIOSIS & CAB Abstracts], EBSCO, DOAJ, Google Scholar, AGRICOLA, ERA, ISC, Citefactor, Rubriq and MyAIS.

AUTHOR SERVICES: We provide a rapid response service to all our authors, with dedicated support staff for each journal, and a point of contact throughout the refereeing and production processes. Our aim is to ensure that the production process is as smooth as possible, is borne out by the high number of authors who prefer to publish with us.

CODE OF ETHICS: Our Journal has adopted a Code of Ethics to ensure that its commitment to integrity is recognized and adhered to by contributors, editors and reviewers. It warns against plagiarism and self-plagiarism, and provides guidelines on authorship, copyright and submission, among others.

PRESS RELEASES: Landmark academic papers that are published in *Pertanika* journals are converted into press releases as a unique strategy for increasing visibility of the journal as well as to make major findings accessible to non-specialist readers. These press releases are then featured in the university's UK-based research portal, ResearchSEA, for the perusal of journalists all over the world.

LAG TIME: The elapsed time from submission to publication for the articles averages 4 to 5 months. A decision on acceptance of a manuscript is reached in 3 to 4 months (average 14 weeks).



An
Award-Winning
International-Malaysian
Journal
—MAY 2014

About the Journal

Pertanika is an international multidisciplinary peer-reviewed leading journal in Malaysia which began publication in 1978. The journal publishes in three different areas — Journal of Tropical Agricultural Science (JTAS); Journal of Science and Technology (JST); and Journal of Social Sciences and Humanities (JSSH).

JTAS is devoted to the publication of original papers that serves as a forum for practical approaches to improving quality in issues pertaining to **tropical agricultural research**- or related fields of study. It is published four times a year in **February, May, August and November**.

JST caters for **science and engineering research**- or related fields of study. It is published twice a year in **January and July**.

JSSH deals in **research or theories in social sciences and humanities research**. It aims to develop as a flagship journal with a focus on emerging issues pertaining to the social and behavioural sciences as well as the humanities, particularly in the Asia Pacific region. It is published four times a year in **March, June, September and December**.

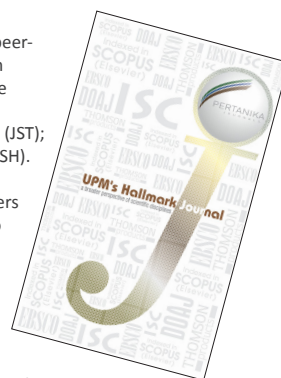

Call for Papers 2014-15 now accepting submissions...

Pertanika invites you to explore frontiers from all key areas of **agriculture, science and technology to social sciences and humanities**.

Original research and review articles are invited from scholars, scientists, professors, post-docs, and university students who are seeking publishing opportunities for their research papers through the Journal's three titles; JTAS, JST & JSSH. Preference is given to the work on leading and innovative research approaches.

Pertanika is a fast track peer-reviewed and open-access academic journal published by **Universiti Putra Malaysia**. To date, *Pertanika* Journals have been indexed by many important databases. Authors may contribute their scientific work by publishing in UPM's hallmark SCOPUS & ISI indexed journals.

Our journals are open access - international journals. Researchers worldwide will have full access to all the articles published online and be able to download them with **zero subscription fee**.

Pertanika uses online article submission, review and tracking system for quality and quick review processing backed by Thomson Reuter's ScholarOne™. Journals provide rapid publication of research articles through this system.

For details on the Guide to Online Submissions, visit http://www.pertanika.upm.edu.my/guide_online_submission.php

Questions regarding submissions should only be directed to the **Chief Executive Editor**, *Pertanika* Journals.

Remember, *Pertanika* is the resource to support you in strengthening research and research management capacity.



Address your submissions to:
The Chief Executive Editor
Tel: +603 8947 1622
nayan@upm.my

Journal's profile: www.pertanika.upm.edu.my



A Stylistic Analysis of News English-Arabic Translation <i>Kais Amir Kadhim</i>	797
Entrepreneurial Leadership Behaviour among School Principals: Perspectives from Malaysian Secondary School Teachers <i>Zaidatul Akmaliah Lope Pihie, Afsaneh Bagheri and Soaib Asimiran</i>	825
Assessing Graduates' Generic Skills: An Indicator of Employability <i>Parmjit Singh, Roslind Xaviour Thambusamy and Adlan Ramly</i>	845
Computer-Mediated Communication Use Among Adolescents and Its Implication for Psychological Need Satisfaction <i>Chin-Siang Ang, Mansor Abu Talib, Jo-Pei Tan and Siti Nor Yaacob</i>	861
Human Governance and Firm's Leverage Decision: Evidence from Malaysian Listed Companies <i>Irene Wei Kiong Ting, Noor Azlinna Azizan and Qian Long Kweh</i>	879
Terras (<i>Eusideroxylon zwageri</i> Teijsm. & Binn.), a Cultural Keystone Species of the Berawan People of Sarawak, Malaysia <i>Franco, F. M., Ghani, B. A. A. and Hidayati, S.</i>	891
Diasporic Dwellings: The Family House and its Role in the Creative Imaginary of Selected Malaysian Indian Writers <i>Shangeetha, R. K. and Pillai, S.</i>	903
Classroom Talk – A Significant Consideration in Developing an Analytical Framework <i>Dass, L. C., Normah, A., Arumugam, N. and Dillah, D.</i>	917

Pertanika Journal of Social Sciences & Humanities
Vol. 22 (3) Sept. 2014

Contents

Foreword	i
<i>Nayan Deep S. Kanwal</i>	
Review Article	
Cross-disciplinary and Cross-linguistic Manifestation of Theme in Academic Writing	695
<i>Ebrahimi, S. F., Chan, S. H. and Tan, B. H.</i>	
Short Communication	
The Relationship between Religiosity and Happiness among Students in an Iranian University	709
<i>Ali Asghar Bayani</i>	
Regular Articles	
Learning Station Method in Special Education Programs for Students with Learning Disabilities	717
<i>Mohd Hanafi Mohd Yasin, Hasnah Toran, Mohd Mokhtar Tahar, Lokman Tahir and Suriawati Nawawi</i>	
Influence of Parents' Jobs on Apprentices' Work Values	729
<i>Nur Surayyah Madhubala Abdullah, Chee Chen Soon and Abdul Rahman Md. Aroff</i>	
Promoting Receptive Vocabulary Growth among Undergraduates: Focused In-Class Reading with Writing Activity	747
<i>Nor Ashikin, A. M., Johana, Y. and Pandian, A.</i>	
Developing Students' Creative Response to Literary Texts in the ESL Classroom	763
<i>Adzura Elier Ahmad and Li Sheau Juin</i>	
Teachers' Self-Efficacy in Teaching Family Life Education	775
<i>Rahimah, J., Abu, R., Ismail, H. and Mat Rashid, A.</i>	
Investigating Thomas Hardy's Reaction to Victorian Religious Forces through Reading <i>Tess of the D'Urbervilles</i> and <i>Jude the Obscure</i>	785
<i>Faezeh Sivandipour and Rosli Talif</i>	



Pertanika Editorial Office, Journal Division
Office of the Deputy Vice Chancellor (R&I)
1st Floor, IDEA Tower II
UPM-MTDC Technology Centre
Universiti Putra Malaysia
43400 UPM Serdang
Selangor Darul Ehsan
Malaysia

<http://www.pertanika.upm.edu.my/>
E-mail: executive_editor_pertanika@upm.my
Tel: +603 8947 1622 / 1619

PENERBIT
UPM
UNIVERSITI PUTRA MALAYSIA
PRESS

<http://penerbit.upm.edu.my>
E-mail : penerbit@putra.upm.edu.my
Tel : +603 8946 8855 / 8854
Fax : +603 8941 6172

