



Research Article

© 2024 Wang et al.
This is an open access article licensed under the Creative Commons
Attribution-NonCommercial 4.0 International License
(<https://creativecommons.org/licenses/by-nc/4.0/>)

Received: 4 October 2023 / Accepted: 19 January 2024 / Published: 5 March 2024

The Moderating Role of Gender in the Effects of an Exercise and Nutrition Intervention Module on Body Composition and Fitness Profiles Among Obese College Students

Ning Wang^{1,3}

Mun Hong Joseph Cheah²

Mahenderan Appukutty^{*}

Yit Siew Chin^{2,4*}

¹Faculty of Sports Science & Recreation, Universiti Teknologi MARA,
40450 Shah Alam, Selangor, Malaysia

²Faculty of Medicine and Health Sciences, Universiti Putra Malaysia,
43400 UPM Serdang, Selangor, Malaysia

³Shanxi Electronic Science and Technology Institute, No.501,
Linfen City, Shanxi Province, 041000, China

⁴Research Centre of Excellence for Nutrition and Non-Communicable Chronic Diseases,
Faculty of Medicine and Health Sciences, Universiti Putra Malaysia,
UPM Serdang, Selangor 43400, Malaysia

*Corresponding Author

DOI: <https://doi.org/10.36941/ajis-2024-0036>

Abstract

Introduction: This study explores how gender and body composition moderate the effects of an exercise and nutrition intervention module on body composition and fitness profiles in obese college students in China, addressing a growing health concern. *Problem Statements:* Obesity is on the rise among Chinese college students, necessitating effective intervention strategies. However, the impact of such interventions may vary based on gender and body composition, a knowledge gaps this study aims to fill. *Methodology/Study Design:* Quantitative research involved 337 college students from the Modern College of Humanities and Sciences, Shanxi Normal University, Linfen, China. Scales were used to assess fitness profiles, body image, exercise, nutrition intervention, and demographics. Data analysis utilised Partial Least Squares Structural Equation Modelling (PLS-SEM). *Results/Findings:* The exercise and diet intervention significantly improved body image and fitness profiles among obese college students. Notably, gender and body composition played crucial roles in moderating the intervention's effects on body image. Female participants experienced more substantial improvements in body image compared to males, with body composition also influencing the exercise-body image relationship. *Implication/Significance:* These findings have theoretical and practical implications. They enhance our understanding of exercise and diet interventions in reshaping body image and fitness profiles among obese college students. Importantly, they highlight the need for personalised interventions, considering gender and body composition. Policymakers and healthcare providers can use these insights to develop more effective programmes, to address the obesity issue among college students in China.

Keywords: Obese college students, exercise and nutrition intervention, body image, fitness profiles, gender, body composition

1. Introduction

Obesity is a pervasive concern affecting individuals across diverse demographic groups globally (Mölenberg et al., 2021). Among college students, elevated obesity rates are attributed to factors such as sedentary lifestyles, consumption of nutritionally deficient foods, and the pressures associated with academic demands (Hossain et al., 2022). Existing research has firmly established a correlation between obesity and body dissatisfaction (Frederick et al., 2022), necessitating an imperative exploration of the underlying causes of low body image among overweight college students (Faro et al., 2021).

Previous studies have extensively examined body image from psychological, sociological, and cultural perspectives (Vandenbosch et al., 2022). The impact of nutrition and exercise on self-perception has also been underscored across various demographic groups (San Martini et al., 2021). Encouragingly, promoting exercise, healthy dietary practices and adequate rest has shown efficacy in enhancing self-esteem (Ruiz-Turrero et al., 2022), with exercise-based interventions demonstrating positive effects on self-esteem, attractiveness, and confidence, thereby contributing to an improved overall body image perception (Balciuniene et al., 2021). Similarly, nutrition-based interventions have proven effective in reshaping body image by fostering positive dietary habits and cultivating favourable body attitudes (Grajek et al., 2022).

However, limited research specifically addresses the impact of exercise and dietary interventions on body image among obese college students (Grajek et al., 2022), a population facing unique challenges, including social stigma and media portrayal, which significantly influence body image perceptions (Koulanova et al., 2021). Consequently, there is a critical need to investigate the impact of these interventions on obese college students, gaining insights into their efficacy and tailoring interventions accordingly (Pfisterer et al., 2022).

Despite valuable insights from earlier research into the interaction between exercise, diet, and body image, significant gaps persist (Pauzé et al., 2021). Most studies have focused on general populations or specific subgroups, neglecting a comprehensive examination of obese college students, who may possess distinct needs and experiences with body image and intervention effects (Balciuniene et al., 2021). Addressing this gap is imperative to elucidate the specific variables influencing body image opinions in this demographic (Mendez, 2021).

Moreover, existing studies exploring the effects of exercise and nutrition on body image often overlook moderating factors such as gender, body composition, and culture (Pryde et al., 2022). Understanding how these factors influence the impact of interventions can provide valuable insights into the complex dynamics at play, facilitating the development of tailored therapies for obese college students (Maddahi et al., 2021).

This study aims to bridge these gaps in the literature, contributing to the current knowledge base on body image and health interventions among obese college students. By focusing exclusively on this demographic, the study seeks to offer insights into the factors influencing body image views and the effectiveness of exercise and nutrition therapies. Understanding the complexities of body image among obese college students and identifying crucial predictors of intervention outcomes can guide the development of targeted interventions that address their unique needs and foster positive body image beliefs (Campedelli et al., 2022).

Furthermore, the study holds practical implications for designing evidence-based interventions that promote positive body image among obese college students. Professionals and practitioners in the field of body image and health interventions can develop more effective programmes by considering individual traits and contextual variables identified as moderating factors impacting intervention results (Ledlow et al., 2023).

The primary objective of this study is to investigate the impact of exercise and dietary interventions on body image among obese college students at Modern College of Humanities and Sciences, Shanxi Normal University, Linfen, China. To achieve this overarching goal, the study outlines specific research objectives:

- a. Evaluate baseline levels of body image and related conceptions concerning behavioural and affective dimensions among obese college students.
- b. Examine how exercise and dietary interventions influence body image views and other characteristics in obese college students.
- c. Investigate the moderating role of gender in the link between exercise and dietary interventions and body image in obese college students.
- d. Explore the mediating role of body composition in the link between exercise and dietary interventions and body image in obese college students.

2. Literature Review

Obesity has emerged as a pressing global concern, extending its impact to the academic setting of the Modern College of Humanities and Sciences, Shanxi Normal University, Linfen, China (Aljaadi et al., 2021). The escalation of obesity rates is particularly pronounced among college students within the country (Aljefree et al., 2022), necessitating immediate attention to devise interventions aimed at enhancing body composition and fitness profiles within this demographic (O'Donoghue et al., 2021). Despite the potential efficacy of exercise and nutrition therapies in combating obesity, the nuanced role of gender in influencing intervention outcomes demands meticulous exploration (Atakan et al., 2021). A comprehensive understanding of how gender modulates the results of exercise and nutrition interventions among obese college students at Modern College of Humanities and Sciences, Shanxi Normal University, Linfen, China holds the promise of informing the development of personalised and gender-specific approaches to address this critical health challenge (Morgan-Bathke et al., 2023).

While exercise and dietary interventions have been extensively studied for their positive impacts on body composition and fitness in obese individuals (Nobari et al., 2022), the moderating influence of gender has often been overlooked (Sánchez-Miguel et al., 2021). Recognising the physiological and behavioural variations between males and females, it is imperative to explore how gender interacts with exercise and dietary interventions, shaping their outcomes (Roshita et al., 2021). This study aims to fill a critical gap in the existing literature by examining the distinct experiences and responses of both male and female obese college students at the Modern College of Humanities and Sciences, Shanxi Normal University, Linfen, China. Through this investigation, we aspire to provide insights into the individual characteristics that may impact the success of intervention modules, offering a nuanced understanding of gender-specific dynamics.

The implications of such findings are substantial, particularly in tailoring obesity interventions to the specific needs of students at the Modern College of Humanities and Sciences, Shanxi Normal University, Linfen, China. Recognising, for example, that female students may respond more positively to specific exercise and dietary strategies allows for the development of customised fitness and nutrition programmes tailored to their preferences. Additionally, these insights can guide the creation of targeted health promotion campaigns, emphasising gender-specific health behaviours and challenges. Practical applications may include the design of educational workshops focusing on nutrition choices and exercise routines aligned with the preferences and biology of both male and female students. In essence, this knowledge equips us with the tools to craft effective, gender-sensitive strategies for addressing obesity and, ultimately, improving the health outcomes of students at Modern College of Humanities and Sciences, Shanxi Normal University, Linfen, China.

2.1 Fitness Profile and Body Image

This study comprehensively evaluates participants' fitness profiles, encompassing parameters such as cardiovascular endurance, muscular strength, flexibility, and body composition (Chiang et al., 2022). Fitness profiles serve as indicative measures of an individual's health and well-being, particularly pertinent in the context of obesity prevention programmes (Batrakoulis, 2022). Examining fitness levels before and after exercise and nutrition interventions facilitates an assessment of their

effectiveness, allowing researchers to discern the impact of such interventions on participants' physical capacities (Bogataj et al., 2021). Furthermore, elucidating the interrelationship between fitness profiles and factors like body image contributes to a more nuanced understanding of the intricate dynamics between physical fitness and psychological well-being (Marschin et al., 2021).

Body image, a pivotal facet of self-perception, encapsulates an individual's thoughts, emotions, and attitudes regarding their physical appearance (Tort-Nasarre et al., 2021). In the context of obesity and health interventions, body image assumes significant importance (Türkay, 2021). For instance, consider the scenario wherein an obese college student's behavioural body image influences their exercise routines and dietary choices, potentially motivating the adoption of a healthier lifestyle through regular exercise and nutritious food selections (Suganyadevi et al., 2022). However, this behavioural aspect is intricately connected to the emotional components of body image (Frayn et al., 2022). If the student grapples with affective body image issues, experiencing dissatisfaction or low self-esteem pertaining to their physical appearance, their sustained motivation to adhere to healthy behaviours may be compromised (Tanck et al., 2021). Consequently, understanding the impact of exercise and nutrition therapies on both the behavioural and affective elements of body image assumes paramount importance. This understanding provides invaluable insights into the psychological and emotional well-being of obese college students, elucidating the intricate interplay between their self-perception, health behaviours, and overall well-being (Hale et al., 2021).

2.2 Nutritional and Exercise Intervention

In the scope of this investigation, the focal independent variables are exercise and dietary interventions (Boukrim et al., 2021). Exercise interventions involve systematically structured physical activity programmes specifically tailored for the purpose of elevating fitness levels, supporting weight management endeavours, and augmenting overall health parameters (Boukrim et al., 2021). These programmes, specifically designed to cater to the unique requirements of obese college students, may encompass aerobic activities, strength training regimens, or a synergistic combination of both modalities (Pfisterer et al., 2022). Conversely, nutrition interventions are pivotal in effecting positive modifications in the dietary behaviours of the targeted student cohort. These interventions are meticulously designed to instil and cultivate healthy eating habits, endorse judicious portion control, and achieve a state of nutritional equilibrium (Lee et al., 2022b). By equipping obese college students with the requisite knowledge and skills to make informed and health-conscious food choices, coupled with effective management of portion sizes, these interventions extend their purview beyond mere considerations of body image and fitness, significantly impacting the holistic health and well-being of the participants. Researchers are particularly interested in examining the impact of exercise and dietary intervention on the dependent variables of fitness profile and body image. Through a meticulous analysis of these variables, the research endeavours to attain a comprehensive understanding of the efficacy of these interventions in elevating the health outcomes of obese college students (Julian et al., 2021). This analytical approach aims to elucidate the multifaceted effects of exercise and dietary interventions, thereby contributing to the scholarly discourse on health promotion strategies tailored to this demographic.

2.3 Gender

In the current investigation, gender assumes a pivotal moderating role, influencing the relationship between the independent variables (exercise and dietary intervention) and the dependent variables (fitness profile and body image). Acknowledging the potential divergences in reactions to interventions based on physiological and behavioural distinctions between males and females, a meticulous examination of gender as a moderating factor becomes imperative (Lee et al., 2022a). This exploration allows researchers to discern potential gender-specific variations in the impacts of exercise and nutrition programmes, thereby facilitating the refinement of intervention strategies in a

gender-sensitive manner (Hayba et al., 2021). Furthermore, a nuanced understanding of the moderating function of gender contributes valuable insights into the intricate effects of interventions on both fitness profile and body image among obese college students, ultimately aiding in the development of tailored and gender-sensitive obesity intervention initiatives (Zou et al., 2022). This analytical approach is instrumental in advancing our comprehension of the nuanced interplay between gender dynamics and the efficacy of interventions within the context of obesity management.

2.4 Body Composition

An additional moderating variable under consideration in this study is body composition, a metric encompassing an individual's fat, muscle, and bone proportions. Body composition assumes significance as it intricately influences metabolic processes, energy expenditure dynamics, and the physiological responses elicited by exercise and nutrition interventions (Burrige et al., 2022). The utilisation of body composition as a moderating variable facilitates examining the nuanced ways in which exercise and nutrition interventions may impact fitness profiles and body image (Jankauskiene et al., 2022). This data proves instrumental in tailoring interventions to accommodate the unique body composition features of obese college students, ensuring their efficacy and promoting optimal health outcomes (refer to Figure 1). This nuanced approach acknowledges the individualised nature of body composition and underscores its relevance in the context of designing effective therapeutic strategies for the target population.

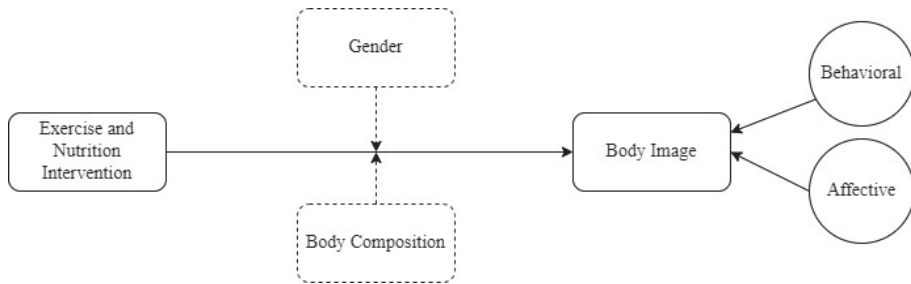

Figure 1: Conceptual Model

H1: Exercise and nutrition intervention significantly affects the body image of fitness profiles and college students.

H2: Body composition significantly moderates the relationship between exercise and nutrition intervention and body image of fitness profiles and college students.

H3: Gender significantly moderates the relationship between exercise and nutrition intervention and body image of fitness profiles and college students.

3. Methodology

This study adopts a quantitative research methodology to investigate the impact of exercise and diet interventions on college students' fitness profiles and body image at Modern College of Humanities and Sciences, Shanxi Normal University, Linfen, China. The sample size, comprising 337 college students, was determined through standard statistical methods, ensuring robust statistical power to discern meaningful differences in the effects of exercise and diet interventions on fitness profiles and body image within the specified population. Data were collected using established measures for assessing fitness profiles, body image, physical activity, and dietary composition. Demographic

information, specifically gender and body composition statistics, was obtained through structured questionnaires. The data underwent analysis employing Partial Least Squares Structural Equation Modeling (PLS-SEM), a statistical tool adept at unravelling intricate relationships within data.

Convenience sampling was employed in participant selection, involving individuals based on their availability and willingness to participate, facilitating a prompt and accessible data collection process. This method was chosen deliberately to encompass a diverse array of college students from the Modern College of Humanities and Sciences, Shanxi Normal University, Linfen, China, thereby enhancing the generalizability of the study's findings.

The data collection involved a questionnaire comprising a ten-item scale for assessing fitness profiles and body image, adapted from the work of Milhausen et al. (2014). To evaluate exercise and nutrition interventions, a fifteen-item scale was utilised, drawing from the study conducted by Dubasi et al. (2019). Body composition was categorised into four groups: underweight, normal, overweight, and obesity.

The study employed validated scales to meticulously assess the variables, comprehensively evaluating participants' physical fitness levels and their perceptions of body image. Additionally, specific scales designed for this research captured pertinent information regarding exercise and dietary composition. Demographic inquiries delved into participants' gender and body composition, providing essential contextual background for the research.

PLS-SEM, a robust statistical methodology suitable for scrutinising complex associations and latent variables, was applied to analyse the collected data. This approach facilitated the exploration of both direct and indirect effects of exercise and diet interventions on fitness profiles and body image, accounting for gender and body composition as moderating factors.

In summary, this study aimed to contribute valuable insights into the impact of exercise and nutrition interventions on fitness profiles and body image among college students at Modern College of Humanities and Sciences, Shanxi Normal University, Linfen, employing a quantitative research approach, validated scales, convenience sampling, and PLS-SEM for rigorous data analysis.

4. Results

The assessment of the measurement scales' reliability in this study was conducted through the utilisation of Cronbach's alpha coefficient, as outlined in Table 1. The outcomes affirm that the variables scrutinised in this investigation exhibited adequate levels of internal consistency. Specifically, the Cronbach's alpha for the affective dimension of body image yielded a value of 0.776, signifying a high degree of reliability in capturing the emotional facets associated with participants' body image. This robust internal consistency suggests that the measurement scale reliably encapsulated the affective dimension of body image and contributes to the overall methodological rigor of the study.

Table 1: Cronbach's Alpha

	Cronbach's Alpha
Affective	0.776
Behavioural	0.714
Fitness Profile and Body Image	0.843
Exercise and nutrition intervention	0.930

The examination of the reliability of measurement scales in this study utilized Cronbach's alpha coefficient. For the behavioural dimension of body image, the calculated Cronbach's alpha was 0.714, signalling an acceptable level of reliability in capturing participants' behavioural features pertaining to body image. The amalgamated scale encompassing fitness profile and body image manifested a Cronbach's alpha of 0.843, indicative of an excellent internal consistency and reliability for this

composite measure. Furthermore, the scale evaluating exercise and nutrition interventions demonstrated a notably high Cronbach's alpha coefficient of 0.930, underscoring the excellent internal consistency and reliability of the assessment tool employed to gauge participants' engagement in exercise and nutrition interventions (refer to Figure 2). These robust reliability coefficients bolster the methodological robustness of the study, instilling confidence in the fidelity of the employed measurement instruments.

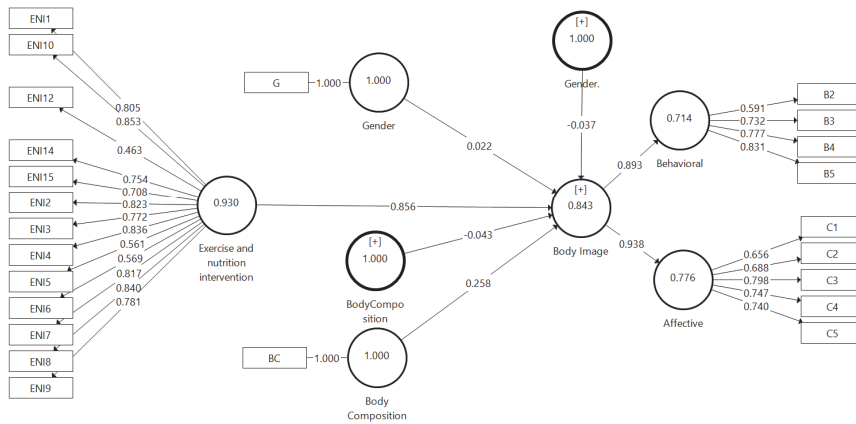

Figure 2: Estimation Model

The study's outcomes are elucidated in the provided table, presenting factor loadings, composite reliability, and average variance extracted (AVE) for the various components under scrutiny. Notably, the "Fitness Profile and Body Image" factor exhibits a commendable composite reliability of 0.878, indicative of robust internal consistency and reliability within the scale. The AVE value for this component, standing at 0.545, implies that the latent construct contributes to approximately 54.5% of the variability observed in the measured items. Factor loadings for the behavioural facet of body image ranged from 0.591 to 0.831, with a corresponding composite reliability of 0.825, affirming excellent internal consistency. The AVE score of 0.545 underscores that the underlying conceptual framework accounts for approximately 54.5% of the observed variable variation.

In the realm of the emotional dimension of body image, factor loadings ranged from 0.656 to 0.798. The composite reliability of 0.848 attests to a high level of internal consistency, and the AVE score of 0.529 suggests that the latent construct elucidates approximately 52.9% of the variability inherent in the tested items. Turning to the exercise and nutrition intervention factor, factor loadings varied from 0.463 to 0.853, with an impressive composite reliability of 0.941, signifying a high level of internal consistency. The AVE score of 0.558 indicates that the underlying conceptualisation encapsulates roughly 55.8% of the variability in the observed variables.

These findings collectively affirm that the assessment scales deployed to evaluate fitness profiles, body image dimensions, and exercise and nutrition interventions demonstrate commendable internal consistency and reliability. The elevated composite reliability scores indicate that the observed variables faithfully represent the underlying constructs. Moreover, the moderate to high AVE values underscore that a substantial proportion of the variance in the observed variables can be attributed to their respective conceptualisations. These robust psychometric properties substantiate the adequacy of the assessment tools employed in the study and instil confidence in the ensuing analyses aimed at investigating the effects of exercise and diet interventions on fitness profiles and body image among the study participants (refer to Table 2).

Table 2: Variables Analysis

	Factor	Original Sample	Composite Reliability	Average Variance Extracted (AVE)
Fitness Profile and Body Image			0.878	0.545
Behavioural	B2	0.591	0.825	0.545
	B3	0.732		
	B4	0.777		
	B5	0.831		
Affective	A1	0.656	0.848	0.529
	A2	0.688		
	A3	0.798		
	A4	0.747		
	A5	0.740		
Exercise and nutrition intervention	ENI1	0.805	0.941	0.558
	ENI10	0.853		
	ENI12	0.463		
	ENI14	0.754		
	ENI15	0.708		
	ENI2	0.823		
	ENI3	0.772		
	ENI4	0.836		
	ENI5	0.561		
	ENI6	0.569		
	ENI7	0.817		
	ENI8	0.840		
	ENI9	0.781		

The discriminant validity of the constructs scrutinised in this study was evaluated using the Fornell-Larcker criteria, and the outcomes are presented in the provided table, delineating correlations between the constructs. The diagonal components for each construct represent the square root of the extracted average variance (AVE), while the inter-construct correlations signify the extent of differentiation between them. Discriminant validity is established when the square root of the AVE for each construct surpasses the correlation between that construct and others, adhering to the Fornell-Larcker criterion.

Per the findings, the "Affective" construct exhibits a square root of AVE of 0.727, signifying robust discriminant validity. Its associations with other constructs spanned from -0.008 to 0.938, underscoring its distinctiveness. Similarly, the "Behavioural" construct boasts a square root of AVE of 0.738, surpassing its correlations with other constructs ranging from 0.162 to 0.893, thus affirming its discriminant validity. The "Body Composition" concept demonstrates sufficient discriminant validity, with a square root of AVE measuring 0.847. Its associations with other constructs ranged from -0.269 to 0.539, reinforcing its uniqueness. The "Body Image" construct, with a square root of AVE of 0.667, outperforms its correlations with other constructs, ranging from 0.016 to 0.938, attesting to its discriminant validity. The "Exercise and Nutrition Intervention" concept surpasses its correlations with other constructs, varying from 0.683 to 0.825, indicating appropriate distinctiveness. Finally, the "Gender" construct, boasting a square root of AVE of 0.755, exceeds its correlations with other constructs, ranging from -0.090 to 0.755, thereby confirming its discriminant validity.

These findings affirm the discriminant validity of the measured constructs, indicating that each concept captures distinct facets of the variables under investigation. This suggests that the constructs are distinct and exhibit minimal overlap, facilitating meaningful interpretation and analysis of their interrelationships in subsequent study phases (refer to Table 3).

Table 3: Fornell-Larcker Criterion

	Affective	Behavioural	Body Composition	Body Image	Exercise and nutrition intervention	Gender
Affective	0.727					
Behavioural	0.683	0.738				
Body Composition	-0.106	0.192	0.847			
Body Image	0.938	0.893	0.016	0.667		
Exercise and nutrition intervention	0.792	0.683	-0.269	0.825	0.747	
Gender	-0.008	0.162	0.539	0.068	-0.090	0.755

In the context of HTMT analysis, a positively moderate association emerged between Body Composition and Body Image, revealing a correlation of 0.314. This association implies that alterations in body composition can indeed influence one's perception of body image, underscoring the intricate interplay between these constructs. Furthermore, the Composite Measure demonstrated a correlation of 0.445 with Body Composition, suggesting that changes in body composition can potentially impact assessments derived from composite measures. This positive correlation underscores the dynamic nature of body composition assessments in relation to broader composite evaluations.

Moving on to the relationship between Exercise and Nutrition Intervention and Body Composition, a positive but moderate correlation of 0.361 was observed. This implies that an individual's engagement in exercise and nutrition interventions may exert an influence on their body composition. This association aligns with the proposition that participation in such interventions can contribute to alterations in body composition. Notably, Exercise and Nutrition Intervention exhibited a robust positive correlation of 0.811 with Body Image, suggesting a substantial connection between an individual's engagement in exercise and nutrition interventions and their perception of body image. This correlation underscores the potential impact of these interventions on shaping individuals' body image perceptions.

Additionally, the correlation of 0.539 between Gender and Body Composition indicates a positive association, emphasising the impact of gender on body composition. These findings shed light on the intricate interconnections among the variables. The interrelated constructs encompassing body composition, exercise and nutrition interventions, gender, and body image suggest a dynamic interplay wherein alterations in one variable may reverberate across the others, as explicated in Table 4. These linkages offer valuable insights into the complex dynamics influencing individuals' perceptions and experiences related to body composition and interventions.

Table 4: HTMT

	Body Composition	Body Image	Exercise and nutrition intervention	Gender
Body Composition				
Body Image	0.314			
Exercise and nutrition intervention	0.361	0.811		
Gender	0.539	0.185	0.168	

The evaluative framework employed to assess the performance of the predictive model in this study encompasses three key metrics: Q₂predict, RMSE (Root Mean Square Error), and MAE (Mean Absolute Error). These metrics collectively furnish insights into the accuracy and precision of the model in forecasting the target outcomes. The computed Q₂predict value, standing at 0.424, signifies that the model adeptly accounted for 42.4% of the variation observed in the anticipated outcomes. This substantial proportion underscores the model's commendable predictive efficacy, indicating a discernible level of predictive prowess.

Turning to the RMSE, an estimated value of 0.077 was obtained, denoting the average disparity

between the expected and actual values. A lower RMSE value corresponds to heightened accuracy and a more precise alignment of the model with the observed data. The attained RMSE score of 0.077 in this context indicates a notably low error rate, implying the model's capacity to generate predictions with high accuracy. Similarly, the resulting MAE value, recorded as 0.085, represents the average absolute difference between the expected and actual values. A lower MAE, akin to a reduced RMSE, implies enhanced precision and a closer alignment between anticipated and observed values. The achieved MAE score of 0.085 underscores the model's effectiveness in minimising average absolute errors, attesting to its robust predictive precision.

In summary, the findings indicate that the predictive model deployed in this study exhibits a moderate level of predictiveness, yielding predictions characterised by relative accuracy and precision. However, it is imperative to acknowledge the inherent limitations and potential sources of inaccuracy inherent in any prediction model. Consequently, further research and validation efforts may be warranted to affirm the model's resilience and applicability across diverse contexts or populations, as delineated in Table 5.

Table 5: Model Fit

Q ² predict	RMSE	MAE
0.424	0.077	0.085

Approximately 88.0% of the variance observed in the Affective variable is explicable through the considered independent variables, as denoted by its R-squared value of 0.880. This substantial R-squared value underscores a proximate association between the independent factors and the Affective variable. Analogously, about 79.8% of the variance discerned in the Behavioural variable is attributable to the independent factors, as signified by the R-squared value of 0.798. This robust R-squared value signifies a robust association between the independent factors and the behavioural variable. Similarly, the independent factors elucidated around 74.4% of the variance identified in the Body Image variable, as reflected in the R-squared value of 0.744. This noteworthy R-squared value underscores a meaningful connection between the independent factors and the Body Image variable.

The elevated R-squared values across these variables signify that the independent variables under examination possess explanatory power, elucidating a substantial portion of the observed variance within these constructs. This statistical insight is corroborated in Table 6, emphasising the robustness of the associations between the independent variables and the corresponding variables of interest.

Table 6: R-Square

Variable	R Square
Affective	0.880
Behavioural	0.798
Body Image	0.744

The F-Square values pertaining to the variables Affective, Behavioural, Body Composition, Body Image, Exercise and Nutrition Intervention, and Gender are delineated in the presented study results table. The F-Square statistic is a metric for gauging each variable's effect size or the proportion of variance explicated. Notably, none of the variables featured in the table exhibited a statistically significant F-Square value concerning the Body Composition variable. This implies that the Body Composition variable did not exert a statistically significant impact on the Affective, Behavioural, Body Image, Exercise and Nutrition Intervention, or Gender variables.

Conversely, the Affective and Behavioural variables manifested noteworthy F-Square values of 7.328 and 3.939, respectively, with regard to the Body Image variable. This substantial effect size

suggests a robust influence of Body Image on both Affective and Behavioural variables, signifying the salience of Body Image in elucidating the variance observed in these constructs. Furthermore, the Body Image variable yielded a significant F-Square value of 1.693 concerning the Exercise and Nutrition Intervention variable. Although of a moderate magnitude, this effect size suggests a discernible impact of Exercise and Nutrition Intervention on explaining the variance within the Body Image variable, as outlined in Table 7.

Table 7: F-Square

	Affective	Behavioural	Body Image
Body Composition			0.162
Body Image	7.328	3.939	
Exercise and nutrition intervention			1.693
Gender			0.008

Body image among college students with a fitness profile was found to be positively affected by exercise and diet intervention, with body composition and gender serving as moderators.

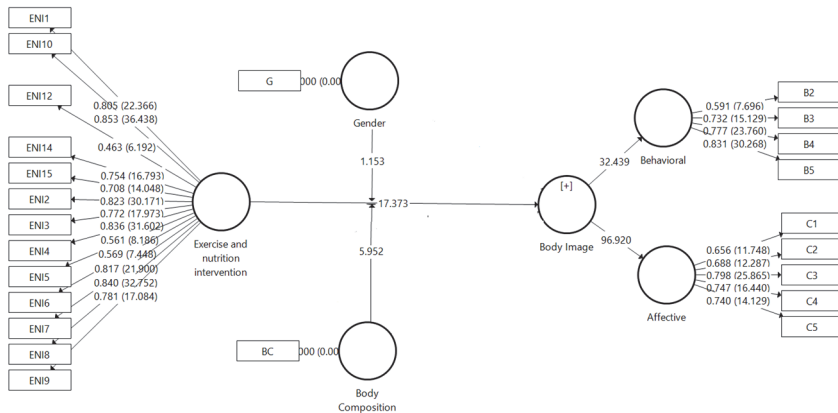

Figure 3: Path analysis for the male group

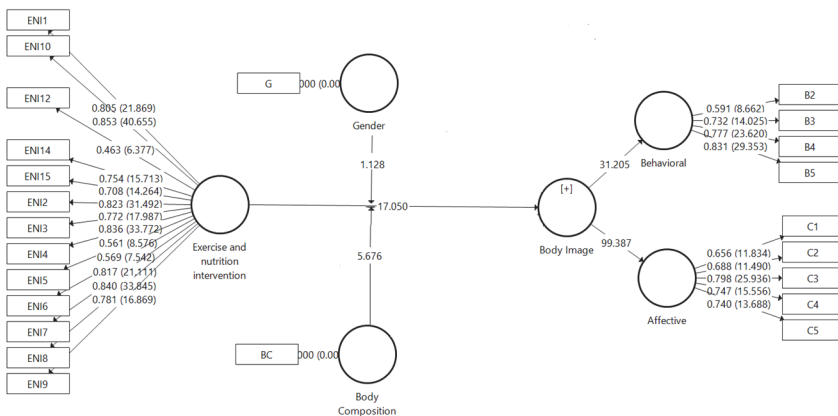

Figure 4: Path Analysis for Females group

The study's outcomes substantiate the validity of the first hypothesis, positing a direct association between exercise and nutrition intervention and self-perception in both male and female participants. Remarkably high t-statistics were observed for both genders, with males registering 17.373 and females 17.050. Furthermore, the exceedingly small p-values (0.000) underscore a robust correlation. These results lend support to the null hypothesis, indicating that college students with elevated fitness profiles stand to benefit significantly from interventions emphasising both physical activity and healthy dietary practices (refer to Figure 3). In consonance with the second hypothesis, body composition emerged as a substantial moderating factor for both genders in the nexus between exercise and diet interventions and body image. Noteworthy t-statistics were evidenced for both male and female cohorts (5.952 and 5.676, respectively), accompanied by highly significant p-values of 0.000. These findings signify a discernible influence of body composition on the association between exercise and nutrition interventions and the interplay of fitness profile and body image in college students, thus corroborating the second hypothesis.

Turning to the examination of gender's moderating role in the relationship between exercise/nutrition interventions and body image, the statistical analysis revealed that gender did not wield a moderating effect for either men or women. Both genders exhibited low t-statistics (1.153 for men and 1.128 for women) in the gender group analysis, with p-values surpassing the 0.05 threshold for both hypotheses. Consequently, the third hypothesis positing the influence of gender on the link between exercise and nutrition intervention and body image in high-fitness students is rejected (see Figure 4). In conclusion, the study's findings offer valuable insights into the intricate dynamics and interplays involving exercise and nutrition interventions, body composition, gender, and self-perception. They underscore the significance of body composition and the direct impact of exercise and dietary interventions on self-perception. However, the evidence suggests that gender does not exert a substantial moderating influence in this context.

Table 8: Path Analysis

	Male				Female			
	Original Sample	Standard Deviation	T Statistics	P Values	Original Sample	Standard Deviation	T Statistics	P Values
H1: Exercise and nutrition intervention significantly affects the body image of fitness profiles and college students.	0.856	0.849	17.373	0.000	0.856	0.847	17.050	0.000
H2: Body composition significantly moderates the relationship between exercise and nutrition intervention and body image of fitness profiles and college students.	0.258	0.258	5.952	0.000	0.258	0.257	5.676	0.000
H3: Gender significantly moderates the relationship between exercise and nutrition intervention and body image of fitness profiles and college students.	-0.037	-0.037	1.153	0.125	-0.037	-0.039	1.128	0.130

5. Discussion

This investigation scrutinised the moderating roles of gender and body composition in the relationship between exercise and nutrition intervention and body image among obese college students, contributing novel insights to this domain. The findings underscored a robust direct

influence of exercise and diet interventions on body image for both male and female participants, aligning with existing research highlighting the positive impact of such interventions on body image perceptions (Baceviciene et al., 2021; Vani et al., 2021). This study adds unique value by focusing specifically on obese college students, emphasising the effectiveness of these interventions in reshaping body image perceptions within this demographic. The results advocate for integrating exercise and nutrition intervention modules in comprehensive therapeutic approaches addressing body image concerns.

Additionally, the investigation explored body composition as a moderator in the exercise-diet-body image relationship, revealing a substantial moderating effect. These outcomes support prior research emphasising the pivotal role of body composition in shaping body image beliefs (Frederick et al., 2022; Frederick et al., 2021). The implication is that individuals with diverse body compositions may respond differentially to exercise and nutrition programmes, highlighting the potential for more tailored and efficacious interventions when accounting for these individual variations. Notably, the study did not observe a significant moderating influence of gender on the association between exercise-diet intervention and body image. This finding contrasts with prior research indicating gender disparities in the impact of exercise and diet interventions on body image (Alharballeh et al., 2021; Gonzales Iv et al., 2021). Exploring potential explanations for this disparity, such as cultural factors, sample characteristics, and the specific metrics employed, may enrich future investigations in understanding the complexities of gender differences in the context of body image and interventions.

Despite its contributions, this study has limitations worth acknowledging. Primarily, its quantitative research approach may constrain the depth of understanding individual experiences and subjective perceptions of body image. Future research incorporating qualitative methodologies could offer a more nuanced exploration of the intricacies of body image beliefs. Moreover, the reliance on convenience sampling might limit the generalizability of the results. Subsequent studies should consider utilising more diverse and representative samples to enhance external validity.

In conclusion, this study illuminates the positive impact of exercise and nutrition interventions on body image evaluations among obese college students, emphasising the moderating role of body composition. While personalised interventions considering individual body composition differences may yield superior outcomes, the non-significant moderating influence of gender suggests comparable benefits for both male and female students in this context. Recognising the study's limitations, future research should continue to delve into these dynamics and explore additional variables influencing the interplay between exercise, diet, body image, and associated outcomes across diverse demographic groups. These efforts may pave the way for the development of more effective interventions and strategies to enhance positive body image and overall well-being among individuals grappling with obesity.

6. Conclusion

This research delves into the intricate dynamics involving gender, body composition, dietary interventions, and exercise programmes within the context of obese college students. The study discerns that exercise and nutrition interventions yield positive effects on body image for both male and female participants, corroborating existing research highlighting the advantageous outcomes of diet and exercise modalities. Notably, the moderating influence of body composition in the intervention-body image relationship underscores the necessity for nuanced, individualised strategies to accommodate diverse body composition profiles. Intriguingly, gender exhibited a less pronounced moderating effect, prompting consideration of cultural nuances and contextual factors in interpreting these results. Acknowledging the study's quantitative methodology and reliance on convenience sampling is imperative for contextualising the findings. Nevertheless, these insights hold pragmatic significance, paving the way for tailored interventions targeting body image concerns among obese college students and potentially informing broader strategies for populations grappling with obesity-related health and body image intricacies.

6.1 Implications

In the realm of practical applications, the findings of this study carry substantial ramifications. Firstly, they illuminate the distinctive challenges confronting obese college students, accentuating the imperative of tailored interventions to address their unique requirements. This underscores the necessity of directing resources and initiatives toward formulating specialised programmes, recognising that universally applicable approaches may inadequately address the nuanced body image and health intricacies prevalent in this demographic. Secondly, the study's practical insights provide a pragmatic viewpoint on the moderating role of body composition in the nexus between exercise, dietary interventions, and body image. In practical terms, this implies that intervention strategies should account for the diverse body compositions of individuals to optimise their efficacy. The observed incongruence between the current study and earlier research suggests potential environmental and cultural factors that warrant further exploration. In a real-world context, this necessitates thorough investigations into these factors to attain a comprehensive comprehension of how gender influences body image and intervention outcomes.

Furthermore, the practical implications underscore the significance of integrating exercise and dietary components into interventions to cultivate positive body image among obese college students. This holistic approach not only addresses psychological facets but also enhances physical well-being. Practitioners can adopt this strategy to formulate and implement more comprehensive programmes, resulting in enduring positive shifts in body image perceptions. Additionally, the case underscores the indispensability of personalised interventions based on individual body composition characteristics. Tailoring interventions to accommodate diverse body compositions is pivotal for achieving favourable outcomes. Practitioners can leverage this approach to refine interventions, augmenting the likelihood of positive alterations in body image perceptions among obese college students. Lastly, the non-significant moderating impact of gender implies that, in practical terms, interventions can be crafted to be gender inclusive. This ensures that both male and female participants can benefit without substantial outcomes disparities. However, during the implementation of these interventions, it is imperative to consider cultural nuances and contextual factors to ensure their efficacy across diverse groups.

In summation, this study furnishes practical insights for professionals engaged in the conception and execution of interventions addressing body image concerns among obese college students. By heeding these implications, practitioners can formulate more efficacious, tailored programmes that foster positive body image and contribute to the holistic well-being of this vulnerable demographic.

6.2 Limitations and Future Research Direction

Despite the notable contributions of this research, it is imperative to acknowledge certain limitations that warrant consideration. Primarily, adopting a quantitative research approach may have delimited the study's comprehension of individual experiences and subjective perceptions concerning body image among obese college students. Future investigations could benefit from employing qualitative methodologies to gain a more comprehensive understanding of the intricate nuances inherent in the body image judgments of this demographic. Secondly, the utilisation of convenience sampling raises concerns regarding sample biases, potentially limiting the generalizability of the findings. Subsequent research endeavours should aspire to employ more diverse and representative samples, encompassing a broader spectrum of demographic characteristics, socioeconomic backgrounds, and geographical regions, thereby enhancing the external validity of the study. Another constraint pertains to focusing on a singular geographic location, specifically China. This region's cultural and socioeconomic milieu may exert influence over body image perspectives and intervention efficacy, necessitating caution when extrapolating the findings to other cultural contexts. Future inquiries should incorporate cross-cultural comparisons to ascertain generalizability and explore cultural nuances that may impact body

image evaluations and the effects of interventions.

The identified limitations suggest several avenues for further research. Incorporating mixed-methods techniques is a promising approach to gain a more profound understanding of the intricate interplay between exercise, diet, body image, and other pertinent elements. By integrating qualitative and quantitative methodologies, researchers can delve into the subjective experiences and perceptions of obese college students, offering a nuanced assessment of intervention success. Subsequent investigations should explore the enduring impact and sustainability of exercise and dietary interventions on body image among this demographic. Follow-up assessments post-intervention could provide valuable insights into the long-term maintenance of favourable body image perspectives. Longitudinal studies also facilitate the exploration of potential mediators and moderators that influence the lasting effects of interventions.

Future research endeavours could further explore the complex interrelationships involving gender, body composition, dietary interventions, and exercise programmes among obese college students, thereby yielding valuable insights. The inclusion of additional variables, such as psychological factors (e.g., self-esteem) and socio-cultural influences, would contribute to a more comprehensive understanding of the multifaceted determinants of body image and health outcomes. Additionally, longitudinal studies tracking the sustained impact of tailored interventions on these variables would furnish valuable data to refine strategies promoting positive body image and overall well-being among this demographic.

Furthermore, expanding the research scope to encompass diverse cultural contexts is crucial. Comparative studies across varied cultural backgrounds would enhance our understanding of the impact of cultural variables on body image perceptions and intervention outcomes. This approach would facilitate the development of culturally responsive solutions tailored to the specific needs and challenges of diverse communities.

Finally, investigating potential moderating variables such as age, socioeconomic status, and educational background would provide a more comprehensive picture of the factors influencing the association between exercise and dietary interventions and body image among obese college students. Addressing these aspects could aid in the formulation of personalised therapies that consider the unique traits and circumstances of individuals. Scholars can advance the field of body image and health interventions by addressing these limitations and pursuing the suggested future research directions, thereby promoting a deeper understanding of the intricate dynamics involved and enhancing the effectiveness of interventions targeting obese college students.

References

- Alharballeh, S., & Dodeen, H. (2021). Prevalence of body image dissatisfaction among youth in the United Arab Emirates: gender, age, and body mass index differences. *Current Psychology*, 1-10.
- Aljaadi, A. M., & Alharbi, M. (2021). Overweight and obesity among Saudi children: prevalence, lifestyle factors, and health impacts. *Handbook of Healthcare in the Arab World*, 1155-1179.
- Aljefree, N. M., & Alhothali, G. T. (2022). Exposure to Food Marketing via Social Media and Obesity among University Students in Saudi Arabia. *International journal of environmental research and public health*, 19(10), 5851.
- Atakan, M. M., Koşar, Ş. N., Güzel, Y., Tin, H. T., & Yan, X. (2021). The role of exercise, diet, and cytokines in preventing obesity and improving adipose tissue. *Nutrients*, 13(5), 1459.
- Baceviciene, M., & Jankauskiene, R. (2021). Changes in sociocultural attitudes towards appearance, body image, eating attitudes and behaviours, physical activity, and quality of life in students before and during COVID-19 lockdown. *Appetite*, 166, 105452.
- Balcuniene, V., Jankauskiene, R., & Baceviciene, M. (2021). Effect of an education and mindfulness-based physical activity intervention for the promotion of positive body image in Lithuanian female students. *Eating and Weight Disorders-Studies on Anorexia, Bulimia and Obesity*, 1-15.
- Batrakoulis, A. (2022). Psychophysiological Adaptations to Pilates Training in Overweight and Obese Individuals: A Topical Review. *Diseases*, 10(4), 71.

- Benton, T. D., Jones, J. D., Juley, S., Butler, L. L., & Boyd, R. C. (2021). 'Web of Violence', Depression, and Impairment in a Clinical Sample of Adolescents. *Journal of Family Violence*, 36, 17-26.
- Bogataj, Š., Trajković, N., Cadenas-Sanchez, C., & Sembler, V. (2021). Effects of school-based exercise and nutrition intervention on body composition and physical fitness in overweight adolescent girls. *Nutrients*, 13(1), 238.
- Boukrim, M., Obtel, M., Kasouati, J., Achbani, A., & Razine, R. (2021). COVID-19 and confinement: Effect on weight load, physical activity and eating behaviour of higher education students in southern Morocco. *Annals of Global Health*, 87(1).
- Burridge, K., Christensen, S. M., Golden, A., Ingersoll, A. B., Tondt, J., & Bays, H. E. (2022). Obesity history, physical exam, laboratory, body composition, and energy expenditure: an Obesity Medicine Association (OMA) Clinical Practice Statement (CPS) 2022. *Obesity Pillars*, 1, 100007.
- Campedelli, V., Ciacchella, C., Veneziani, G., Meniconzi, I., Paone, E., Silecchia, G., & Lai, C. (2022). Body Image and Body Mass Index Influence on Psychophysical Well-Being in Bariatric Patients: A Cross-Sectional Study. *Journal of Personalized Medicine*, 12(10), 1597.
- Chiang, H.-H., Lee, P.-F., Chen, Y.-T., Lin, C.-F., Xu, S., Lin, Y.-T., . . . ChangChien, W.-S. (2022). Low Cardiorespiratory Fitness, Muscular Fitness, and Flexibility Are Associated with Body Fat Distribution and Obesity Risk Using Bioelectrical Impedance in Taiwanese Adults. *International journal of environmental research and public health*, 19(14), 8858.
- Dubasi, S. K., Ranjan, P., Arora, C., Vikram, N. K., Dwivedi, S. N., Singh, N., . . . Shalimar. (2019). Questionnaire to assess adherence to diet and exercise advices for weight management in lifestyle-related diseases. *J Family Med Prim Care*, 8(2), 689-694. doi:10.4103/jfmpc.jfmpc_338_18
- Faro, J. M., Whiteley, J. A., Hayman, L. L., & Napolitano, M. A. (2021). Body image quality of life related to light physical activity and sedentary behavior among young adults with overweight/obesity. *Behavioural Sciences*, 11(8), 111.
- Frayn, M., & Knäuper, B. (2022). Emotional eating and weight in adults: a review. *Key Topics in Health, Nature, and Behavior*, 1-10.
- Frederick, D. A., Crerand, C. E., Brown, T. A., Perez, M., Best, C. R., Cook-Cottone, C. P., . . . Malcarne, V. L. (2022). Demographic predictors of body image satisfaction: The US Body Project I. *Body Image*, 41, 17-31.
- Frederick, D. A., & Reynolds, T. A. (2021). The value of integrating evolutionary and sociocultural perspectives on body image. *Archives of sexual behavior*, 1-10.
- Gonzales Iv, M., & Blashill, A. J. (2021). Ethnic/racial and gender differences in body image disorders among a diverse sample of sexual minority US adults. *Body Image*, 36, 64-73.
- Grajek, M., Krupa-Kotara, K., Grot, M., Kujawińska, M., Helisz, P., Gwioździk, W., . . . Kobza, J. (2022). Perception of the Body Image in Women after Childbirth and the Specific Determinants of Their Eating Behavior: Cross-Sectional Study (Silesia, Poland). *International journal of environmental research and public health*, 19(16), 10137.
- Hale, G. E., Colquhoun, L., Lancaster, D., Lewis, N., & Tyson, P. J. (2021). Physical activity interventions for the mental health and well-being of adolescents—a systematic review. *Child and adolescent mental health*, 26(4), 357-368.
- Hayba, N., Khalil, C., & Allman-Farinelli, M. (2021). Enabling better nutrition and physical activity for adolescents from middle eastern backgrounds: focus groups. *Nutrients*, 13(9), 3007.
- He, J., Cai, Z., Chen, X., Lu, T., & Fan, X. (2021). Validation of the Chinese version of the body image acceptance and action questionnaire and the mediating role of body image flexibility in the relationship between body dissatisfaction and psychological distress. *Behavior therapy*, 52(3), 539-551.
- Hossain, M. J., Ahmmmed, F., Khan, M. R., Rashid, P. T., Hossain, S., Rafi, M. O., . . . Islam, F. (2022). Impact of prolonged COVID-19 lockdown on body mass index, eating habits, and physical activity of university students in Bangladesh: a web-based cross-sectional study. *Frontiers in nutrition*, 9, 873105.
- Jankauskiene, R., Urmanavicius, D., & Baceviciene, M. (2022). Association between Motivation in Physical Education and Positive Body Image: Mediating and Moderating Effects of Physical Activity Habits. *International journal of environmental research and public health*, 20(1), 464.
- Julian, V., Ciba, I., Olsson, R., Dahlbom, M., Furthner, D., Gomahr, J., . . . Schneider, A. (2021). Association between metabolic syndrome diagnosis and the physical activity—sedentary profile of adolescents with obesity: A complementary analysis of the beta-judo study. *Nutrients*, 14(1), 60.
- Koulanova, A., Sabiston, C. M., Pila, E., Brunet, J., Sylvester, B., Sandmeyer-Graves, A., & Maginn, D. (2021). Ideas for action: Exploring strategies to address body image concerns for adolescent girls involved in sport. *Psychology of Sport and Exercise*, 56, 102017.
- Ledlow, G. R., Bosworth, M., & Maryon, T. (2023). *Leadership for health professionals: Theory, skills, and applications*: Jones & Bartlett Learning.

- Lee, Y., Kim, T., & Jung, H. (2022a). Effects of University Students' Perceived Food Literacy on Ecological Eating Behavior towards Sustainability. *Sustainability*, 14(9), 5242.
- Lee, Y., Kim, T., & Jung, H. (2022b). The relationships between food literacy, health promotion literacy and healthy eating habits among young adults in South Korea. *Foods*, 11(16), 2467.
- Maddahi, A., Hani, J. B., Asgari, A., Nassiri, A. M., & Choukou, M. (2021). Therapists' perspectives on a new portable hand telerehabilitation platform for home-based personalized treatment of stroke patients. *Eur Rev Med Pharmacol Sci*, 18, 5790-5800.
- Marschin, V., & Herbert, C. (2021). Yoga, Dance, Team Sports, or Individual Sports: Does the Type of Exercise Matter? An Online Study Investigating the Relationships Between Different Types of Exercise, Body Image, and Well-Being in Regular Exercise Practitioners. *Frontiers in Psychology*, 12, 621272.
- Mendez, N. (2021). *Afro-Latinx Caribbean Women's Body Image: A Mixed-Methodology Inquiry on Gender, Race, and Culture*: Columbia University.
- Milhausen, R., Buchholz, A., Opperman, E., & Benson, L. (2014). Relationships Between Body Image, Body Composition, Sexual Functioning, and Sexual Satisfaction Among Heterosexual Young Adults. *Archives of sexual behavior*, 44. doi:10.1007/s10508-014-0328-9
- Mölenberg, F. J. M., Mackenbach, J. D., Poelman, M. P., Santos, S., Burdorf, A., & van Lenthe, F. J. (2021). Socioeconomic inequalities in the food environment and body composition among school-aged children: a fixed-effects analysis. *International journal of obesity*, 45(12), 2554-2561.
- Morgan-Bathke, M., Raynor, H. A., Baxter, S. D., Halliday, T. M., Lynch, A., Malik, N., . . . Rozga, M. (2023). Medical Nutrition Therapy Interventions Provided by Dietitians for Adult Overweight and Obesity Management: An Academy of Nutrition and Dietetics Evidence-Based Practice Guideline. *Journal of the Academy of Nutrition and Dietetics*, 123(3), 520-545.
- Nobari, H., Gandomani, E. E., Reisi, J., Vahabidshad, R., Suzuki, K., Volpe, S. L., & Pérez-Gómez, J. (2022). Effects of 8 weeks of high-intensity interval training and spirulina supplementation on immunoglobulin levels, cardio-respiratory fitness, and body composition of overweight and obese women. *Biology*, 11(2), 196.
- O'Donoghue, G., Blake, C., Cunningham, C., Lennon, O., & Perrotta, C. (2021). What exercise prescription is optimal to improve body composition and cardiorespiratory fitness in adults living with obesity? A network meta-analysis. *Obesity Reviews*, 22(2), e13137.
- Pauzé, A., Plouffe-Demers, M.-P., Fiset, D., Saint-Amour, D., Cyr, C., & Blais, C. (2021). The relationship between orthorexia nervosa symptomatology and body image attitudes and distortion. *Scientific Reports*, 11(1), 13311.
- Pfisterer, J., Rausch, C., Wohlfarth, D., Bachert, P., Jekauc, D., & Wunsch, K. (2022). Effectiveness of Physical-Activity-Based Interventions Targeting Overweight and Obesity among University Students—A Systematic Review. *International journal of environmental research and public health*, 19(15), 9427.
- Pryde, S., & Prichard, I. (2022). TikTok on the clock but the# fitspo don't stop: The impact of TikTok fitspiration videos on women's body image concerns. *Body Image*, 43, 244-252.
- Roshita, A., Riddell-Carre, P., Sjahrial, R., Jupp, D., Torlesse, H., Izwardy, D., & Rah, J. H. (2021). A qualitative inquiry into the eating behavior and physical activity of adolescent girls and boys in Indonesia. *Food and Nutrition Bulletin*, 42(1_suppl), S122-S131.
- Ruiz-Turrero, J., Massar, K., Kwasnicka, D., & Ten Hoor, G. A. (2022). The relationship between compulsive exercise, self-esteem, body image and body satisfaction in women: a cross-sectional study. *International journal of environmental research and public health*, 19(3), 1857.
- San Martini, M. C., de Assumpcao, D., de Azevedo Barros, M. B., de Azevedo Barros Filho, A., & Mattei, J. (2021). Weight self-perception in adolescents: evidence from a population-based study. *Public Health Nutrition*, 24(7), 1648-1656.
- Sánchez-Miguel, P. A., Sevil-Serrano, J., Sánchez-Oliva, D., Vaquero-Solis, M., & Tapia-Serrano, M. A. (2021). Does gender moderate the relationship between physical activity and body dissatisfaction among adolescents? *Journal of Gender Studies*, 30(6), 676-686.
- Suganyadevi, S., Shamia, D., & Balasamy, K. (2022). An IoT-based diet monitoring healthcare system for women. *Smart Healthcare System Design: Security and Privacy Aspects*, 167-202.
- Tanck, J. A., Hartmann, A. S., Svaldi, J., & Vocks, S. (2021). Effects of full-body mirror exposure on eating pathology, body image and emotional states: Comparison between positive and negative verbalization. *Plos one*, 16(9), e0257303.
- Tort-Nasarre, G., Pollina Pocallet, M., & Artigues-Barberà, E. (2021). The meaning and factors that influence the concept of body image: Systematic review and meta-ethnography from the perspectives of adolescents. *International journal of environmental research and public health*, 18(3), 1140.

- Türkyay, I. K. (2021). Investigation of Social Appearance Anxiety Levels of Physical Education and Teaching, Coaching Education and Sports Management Department Students in Terms of Different Variables. *Journal of Educational Issues*, 7(2), 455-472.
- Vandenbosch, L., Fardouly, J., & Tiggemann, M. (2022). Social media and body image: Recent trends and future directions. *Current opinion in psychology*, 45, 101289.
- Vani, M. F., Murray, R. M., & Sabiston, C. M. (2021). Body image and physical activity. *Essentials of Exercise and Sport Psychology: An Open Access Textbook*; Zenko, Z., Jones, L., Eds, 150-175.
- Zou, M., Northstone, K., & Leary, S. (2022). Prospective association between later eating and obesity in school-age children from the China Health and Nutrition Survey (CHNS).